



MAKSIWA®

SC.1100.X

10" Table Saw - 3 Wire 220 V - 1 Phase

INSTRUCTION MANUAL

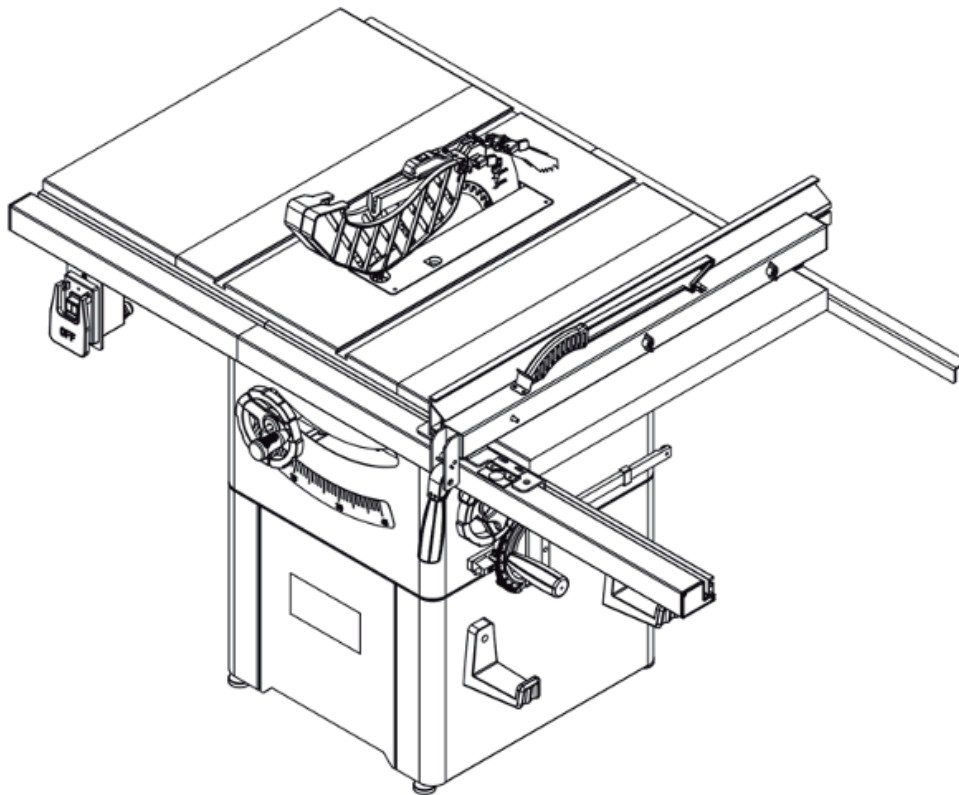

ATTENTION: READ THIS MANUAL BEFORE USING THE MACHINE.

Greetings,

Congratulations, you just purchased the SC.1100.X Maksiwa Table Saw, which was developed with the Maksiwa's highest standards of technology and quality. Your SC.1100.X Maksiwa Table Saw allows you to have the highest productivity in woodworking. It should be noted that to use this machine with maximum efficiency, you should read and understand the instructions in this manual.

Visit our website to know about our launches and other product lines and Technical Assistance:

www.maksiwa.com/usa

tech@maksiwa.com



Attention!: The machine must be inspected immediately upon arrival. If the machine has been damaged during transport, or if any parts are missing, a written record of the problems must be submitted to the forwarding agent and a damage report compiled. Also be sure to notify your supplier immediately.



For the safety of all personnel, it is necessary to study this manual thoroughly before assembly and operation. This manual must be kept in good condition and should be considered as part of the machine. Furthermore, the manual must be kept to hand and within the vicinity of the machine so that it is accessible to operators when using, maintaining or repairing the machine.



Maksiwa International Inc.
4100 N Powerline Rd, Suite D3 Pompa-
no Beach, FL

Call us free: 844-319-6594

tech@maksiwa.com
www.maksiwa.com/usa

Contents

1. General.....	05
1.1 Symbol legend.....	05
1.2 Information on the operating instructions	05
1.3 Liability and warranty.....	05
1.4 Copyright.....	06
1.5 Spare parts.....	06
1.6 Disposal	06
2. Safety Regulations.....	07
2.1 Workspace.....	07
2.2 Maintainance	07
2.3 Machine Safety.....	08
3. Specifications.....	13
3.1 Technical Specifications	13
3.2 Electrical Requirements	13
4. Installation.....	15
4.1 Unpacking and Checking Contents	15
4.2 Assembly	16
5. Operating Procedures	28
5.1 Description	28
5.2 Starting and Stopping the Saw	28
5.3 Adjustments	29
5.4 Types of Cuts/Operations	32
6. Maintenance	36
6.1 Safety Instructions	36
6.2 Cleaning	36
6.3 Lubrication	36
6.4 Service	36
6.5 Changing the Blade Saw	37
7. Troubleshooting	38
8. Exploded View	40
9. Wiring Diagram	50
10. Terms of Warranty.....	51

1 General

1.1 Symbol legend

Important technical safety instructions in this manual are marked with symbols. These instructions for work safety must be followed.

In all these particular cases, special attention must be paid in order to avoid accidents, injury to persons or material damage.



Warning! Risk of injury or death!

This symbol marks instructions that must be followed in order to avoid harm to one's health, injuries, permanent impairment or death!



Warning! Danger! Electric current!

This symbol warns of potentially dangerous situations relating to electrical current. Not observing the safety instructions increases the risk of serious injury or death. All electrical repairs must be carried out by a qualified electrician!



Attention! Risk of material damage!

This symbol marks instructions which, if not observed, may lead to material damage, functional failures and/or machine breakdown!

1.2 Information on the operating instructions

This manual describes how to operate the machine properly and safely. Be sure to follow the safety tips and instructions stated here as well as any local accident prevention regulations and general safety regulations. Before beginning any work on the machine, ensure that the manual, in particular the chapter entitled "Safety" and the respective safety guidelines, has been read in its entirety and fully understood. This manual is an integral part of the machine and must therefore be kept in the direct vicinity of the machine and be accessible at all times. If the machine is sold, rented, lent or otherwise transferred to another party, the manual must accompany the machine.

1.3 Liability and warranty

The contents and instructions in this manual have been compiled in consideration of current regulations and state-of-the-art technology as well as based on our know-how and experience acquired over many years. This

manual must be read carefully before commencing any work on or with this machine. The manufacturer shall not be liable for damage and/or faults resulting from the disregard of instructions in the manual. The text and images do not necessarily represent the delivery contents. The images and graphics are not depicted on a 1:1 scale. The actual delivery contents are dependent on custom-build specifications, add-on options or recent technical modifications and may therefore deviate from the descriptions, instructions and images contained in the manual. Should any questions arise, please contact the manufacturer. We reserve the right to make technical modifications to the product in order to further improve user-friendliness and develop its functionality.

1.4 Copyright

This manual should be handled confidentially. It is designated solely for those persons who work on or with the machine. All descriptions, texts, drawings, photos and other depictions are protected by copyright and other commercial laws. Illegal use of the materials is punishable by law.

This manual, in its entirety or parts thereof, may not be transferred to third parties or copied in any way or form, and its contents may not be used or otherwise communicated without the express written consent of the manufacturer.

Infringement of these rights may lead to a demand for compensation or other applicable claims. We reserve all rights in exercising commercial protection laws.

1.5 Spare parts

 Attention: Non genuine, counterfeit or faulty spare parts may result in damage, cause malfunction or complete breakdown of the machine.

If unauthorized spare parts are fitted into the machine, all warranty, service, compensation and liability claims against the manufacturer and their contractors, dealers and representatives shall be rejected. Use only genuine spare parts supplied by the manufacturer. Unless, specified by manufacturer.

1.6 Disposal

 **Attention!: Used electrical materials, electronic components, lubricants and other auxiliary substances must be treated as hazardous waste and may only be disposed of by specialised, licensed firms.**

If the machine is to be disposed of, separate the components into the various materials groups in order to allow them to be reused or selectively disposed of. The whole structure is made of steel and can therefore be dismantled without problem. This material is also easy to dispose of and does not pollute the environment or jeopardize public health. International environmental regulations and local disposal laws must always be complied with.

2 Safety Regulations

For your own safety, read all of the instructions and precautions before operating tool.

- Wear proper apparel. Do not wear loose clothing, gloves, neckties, rings, bracelets or other jewelry which may get caught in moving parts of machine.
- Wear protective hair covering to contain long hair.
- Wear safety shoes with non-slip soles.
- Wear safety glasses complying with the Standard of your country. Everyday glasses have only impact resistant lenses. They are NOT safety glasses.
- Wear face mask or dust mask if operation is dusty.
- Be alert and think clearly. Never operate power tools when tired, intoxicated or when taking medications that cause drowsiness.

2.1 Workspace

- Keep work area clean. Cluttered work areas invite accidents.
- Do not use power tools in dangerous environments. Do not use power tools in damp or wet locations. Do not expose power tools to rain.
- Work area should be properly lighted.
- Keep visitors at a safe distance from work area.
- Keep children out of workplace. Make workshop childproof. Use padlocks, master switches or remove switch keys to prevent any unintentional use of power tools.
- Keep power cords from coming in contact with sharp objects, oil, grease and hot surfaces.

2.2 Maintenance

- **Always unplug tool prior to inspection.**
- **Consult manual for specific maintaining and adjusting procedures.**
- **Keep tool lubricated and clean for safest operation.**
- **Remove adjusting tools. Form habit of checking to see that adjusting tools are removed before switching machine on.**
- **Keep all parts in working order. Check to determine that the guard or other parts will operate properly and perform their intended function.**
- **Check for damaged parts. Check for alignment of moving parts, binding, breakage, mounting and any other condition that may affect a tool's operation.**
- **A guard or other part that is damaged should be properly repaired or replaced. Do not perform makeshift repairs. (Use parts list provided to order replacement parts.)**

- **Maintain proper adjustment of rip fence and blade guard.**
- **Never adjust saw while running. Disconnect power to avoid accidental start-up.**
- **Have damaged or worn power cords replaced immediately.**
- **Keep blade sharp for efficient and safest operation.**

2.3 Machine Safety

- Use right tool for job. Do not force tool or attachment to do a job for which it was not designed.
- Disconnect tool when changing blade.
- Avoid accidental start-up. Make sure that the tool is in the “off” position before plugging in, turning on safety disconnect or activating breakers.
- Do not force tool. It will work most efficiently at the rate for which it was designed.
- Keep hands away from blade and moving parts and cutting surfaces.
- Never leave tool running unattended. Turn the power off and do not leave tool until it comes to a complete stop.
- Do not overreach. Keep proper footing and balance.
- Never stand on tool. Serious injury could occur if tool is tipped or if blade is unintentionally contacted.
- Know your tool. Learn the tool’s operation, application and specific limitations.
- Handle workpiece correctly. Press firmly against table. Protect hands from possible injury.
- Turn machine off if it jams. Blade jams when it digs too deeply into workpiece. (Motor force keeps it stuck in the work.)
- Feed work into the blade only as recommended in “Operation.”.

WARNING! FOR YOUR OWN SAFETY, DO NOT OPERATE YOUR SAW UNTIL IT IS COMPLETELY ASSEMBLED AND INSTALLED ACCORDING TO INSTRUCTIONS.

STABILITY OF SAW

If there is any tendency for the saw to tip over or move during certain cutting operations, such as cutting extremely heavy panels or long heavy boards, the saw should be bolted down. If you attach any kind of extensions over 24" wide to either end of the saw, make sure you either bolt the saw to the floor, as appropriate, or support the outer end of the extension from the bench or floor, as appropriate.

LOCATION

The saw should be positioned so neither the operator nor a casual observer is forced to stand in line with the saw blade.

KICKBACKS

A kickback occurs during a rip-type operation when a part or all of workpiece is thrown back violently toward operator. Keep your face and body to one side of the saw blade, out of line with a possible kickback. Kickbacks

and possible injury from them can usually be avoided by:

- Maintaining rip fence parallel to saw blade.
- Keeping saw blade sharp. Replace or sharpen anti-kick-back pawls when points become dull.
- Keeping saw blade guard, spreader, and anti-kickback pawls in place and operating properly. The spreader must be in alignment with the saw blade and the pawls must stop a kickback once it has started. Check their action before ripping.
- Not ripping work that is twisted or warped or does not have a straight edge to guide along the rip fence.
- Not releasing work until you have pushed it all the way past the saw blade.
- Using a push stick for ripping widths less than 6 inches.
- Not confining the cutoff piece when ripping or crosscutting.

PROTECTION: EYES, HANDS, FACE, BODY, EARS

- If any part of your saw is missing, malfunctioning, or has been damaged or broken (such as the motor switch, electronic controls, other operating control, a safety device or power cord), cease operating immediately until the particular part is properly repaired or replaced.
- Wear safety goggles that comply with the standard of your country and a face shield or dust mask if operation is dusty. Wear ear plugs or muffs during extended periods of operation.
- Small loose pieces of wood or other objects that contact the rear of the revolving blade can be thrown back at the operator at excessive speed. This can usually be avoided by keeping the guard and spreader in place for all thru-sawing operations (sawing entirely thru work) and by removing all loose pieces from the table with a long stick of wood immediately after they are cut off.
- Use extra caution when the guard assembly is removed for resawing, dadoing, or rabbeting, replace guard as soon as that operation is completed.
- Never turn the saw ON before clearing the table of all tools, wood scraps, etc., except the workpiece and related feed or support devices for the operation planned.
- Never place your face or body in line with the cutting tool.
- Never place your fingers or hands in path of saw blade or other cutting tool.
- For rip or rip-type cuts, the following end of a workpiece to which a push stick or push board is applied must be square (perpendicular to the fence) in order that feed pressure applied to the workpiece by the push stick or block does not cause the workpiece to come away from the fence, and possibly cause a kickback.
- During rip and rip-type cuts, workpiece must be held down on table and against fence with a push stick, push block, or feather boards, as applicable (see following figures).
- Push stick: A safety device used to push the workpiece through a cutting operation. Used most often when rip cutting thin workpieces.
- The push stick and push block examples shown below are useful for keeping hands and fingers away from saw blade during ripping, rabbeting and dadoing. Apply downward pressure and push workpiece through the cut and past the blades. Several other configurations may be suitable for safe operation. Feather boards are used to keep the work in contact with the rip fence or table during the cutting operation. Use of feather

boards can help to prevent kickbacks and binding. Feather boards should be used for all “non thru-sawing” operations.

- Never reach in back of the cutting tool with either hand to hold down or support the workpiece, remove wood scraps, or for any other reason. Avoid awkward operations and hand positions where a sudden slip could cause fingers or hand to move into a saw blade or other cutting tool.
- Do not perform layout, assembly, or setup work on the table while the cutting tool is rotating.
- Do not perform any operation freehand—always use either rip fence or miter gauge to position and guide the work.
- Never use the rip fence when cross-cutting or the miter gauge when ripping. Do not use rip fence as a length stop. Never hold onto or touch free-end of workpiece or a free-piece that is cut off, while power is ON and/or saw blade is rotating.
- Shut the saw OFF and disconnect power source when removing the table insert, changing the cutting tool, removing or replacing the blade guard, or making adjustments.
- Provide adequate support to the rear and sides of the saw table for wide or long workpieces.
- Plastic and composition materials (like hardboard) may be cut on your saw. However, since these are usually quite hard and slippery, the anti-kickback pawls may not stop a kickback. Therefore, be especially attentive to following proper setup and cutting procedures for ripping. Do not stand, or permit anyone else to stand, in line with a potential kickback.
- If you stall or jam the saw blade in the workpiece, turn saw OFF and remove the workpiece from the saw blade. Check to see if the saw blade is parallel to the miter gauge grooves and if the spreader is in proper alignment with the saw blade. If ripping at the time, check to see if the rip fence is parallel with the saw blade. Readjust as required.
- Do not remove small pieces of cutoff material that may become trapped inside the blade guard while the saw is running. This could endanger your hands or cause kick-back. Turn saw OFF and wait until blade stops.
- Use extra care when ripping wood with twisted grain or wood that is twisted or bowed—it may rock on table and pinch saw blade.

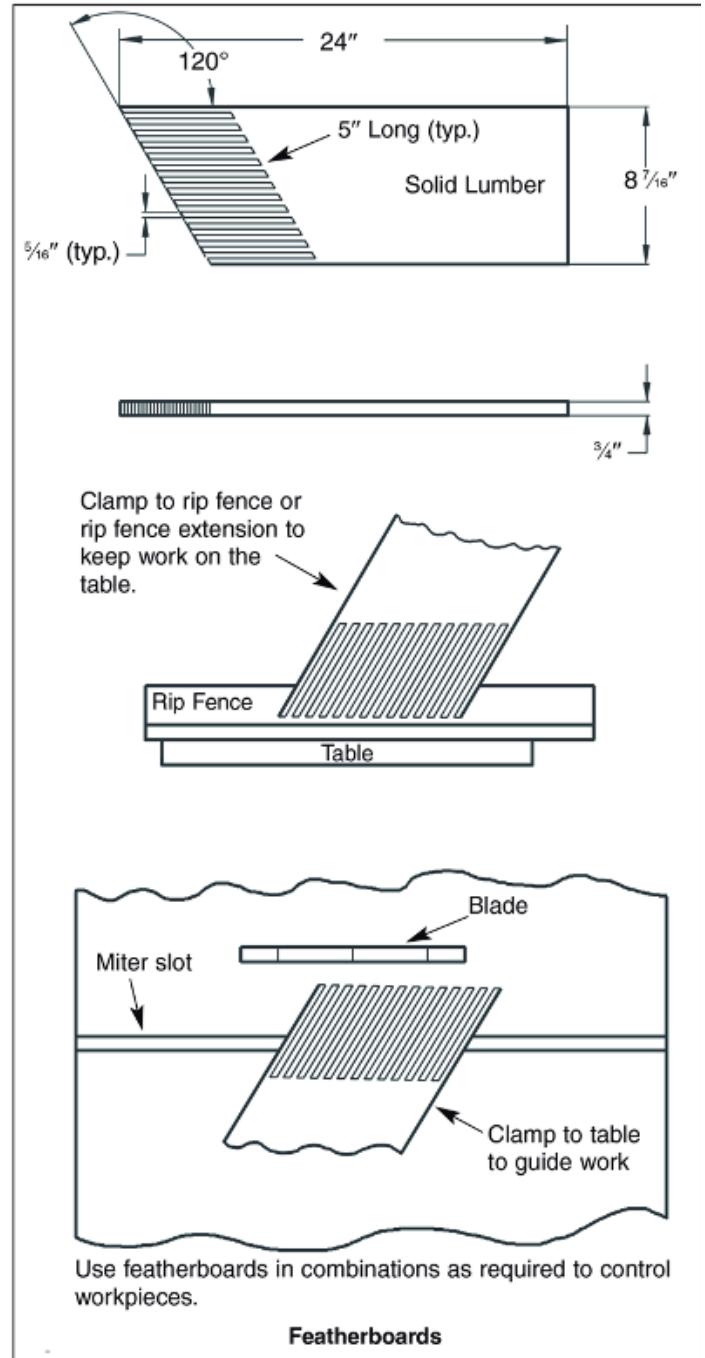
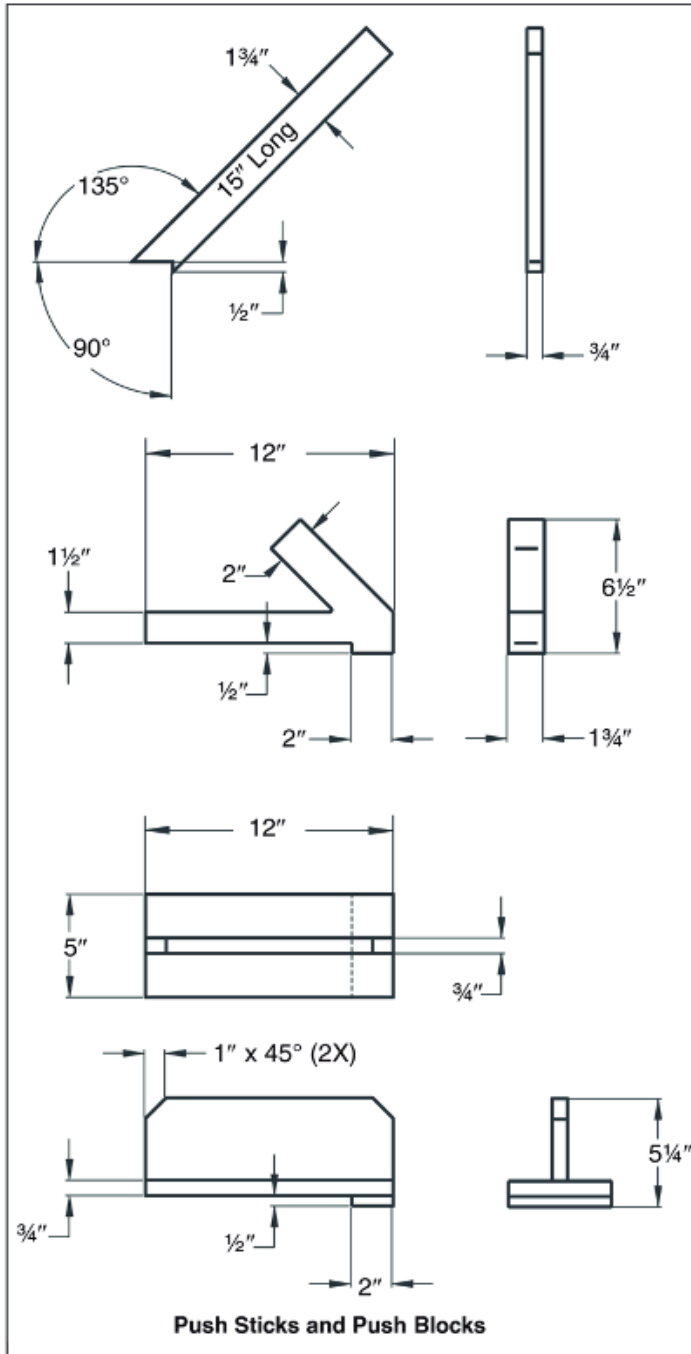

KNOW YOUR CUTTING TOOLS

- Dull, gummy, improperly sharpened or set cutting tools can cause material to stick, jam, stall saw, or kickback at operator. Minimize potential injury by proper care and machine maintenance.

WARNING: Never attempt to free a stalled saw blade without first turning saw OFF.

- Never use grinding wheels, abrasive cutoff wheels, friction wheels (metal slitting blades), wire wheels or buffing wheels.

USE ONLY ACCESSORIES DESIGNED FOR SAW

- Crosscutting operations are worked more conveniently and with greater safety if an auxiliary wood facing is attached to miter gauge using holes provided. However, facing must not interfere with proper functioning of saw blade guard.
- Make sure the top of the arbor or cutting tool rotates toward you when standing in normal operating position. Also make sure the cutting tool, blade flange and arbor nut are installed properly. Keep the cutting tool as low as possible for the operation being performed. Keep all guards in place whenever possible.
- Do not use any blade or other cutting tool marked for operating speed less than 4000 RPM. Never use a cutting tool larger in diameter than diameter for which saw was designed. For greatest safety and efficiency when ripping, use maximum diameter blade for which saw is designed, since under these conditions spreader is nearest the blade.
- Adjust table inserts flush with table top. Never operate saw unless proper insert is installed.
- Never feed material into the cutting tool from the rear of the saw. An accident and serious injury could result.

THINK SAFETY

Safety is a combination of operator common sense and alertness at all times when the saw is being used. Never use another person as a substitute for a table extension, or as additional support for a workpiece that is longer or wider than basic saw table, or to assist in feeding, supporting or pulling the workpiece.

Do not pull the workpiece through the saw blade—position your body at the infeed side of the guard; start and complete the cut from that same side. This will require added table support for long or wide workpieces that extend beyond the length or width of the saw table.

CAUTION: Follow safety instructions that appear on the front of your saw.

3 Specifications

3.1 Technical Specifications

Please choose proper power source, voltage and frequency that are shown in the label for your machine.

10" Contractor Table Saw	
Motor	2.5 Hp 8 Amp or A 1800W
Table Size	20"X 27" (508X685mm)
Extended Table Size	44" X 27" (1118X685mm)
Saw Blade	10" X 5/8" (254x15.875mm)
Maximum Cut Depth at 90°	3-1/8 " (80mm)
Maximum Cut Depth at 45°	2-3/16" (55mm)
Blade angle	0~45°
Max. Ripping Capacity	30" (762mm)
Blade Speed	60Hz 3450 RPM

3.1 Electrical Requirements

POWER SUPPLY AND MOTOR SPECIFICATIONS

WARNING: To avoid electrical hazards, fire hazards, or damage to the tool, use proper circuit protection. Use a separate electrical circuit for your tools. To avoid shock or fire, if power cord is worn or cut, or damaged in any way, have it replaced immediately.

GROUNDING INSTRUCTIONS

WARNING: This tool must be grounded while in use to protect the operator from electrical shock.

IN THE EVENT OF A MALFUNCTION OR BREAKDOWN, grounding provides a path of least resistance for electric current and reduces the risk of electric shock. This tool is equipped with an electric cord that has an equipment-grounding conductor and a grounding plug. The plug **MUST** be plugged into a matching receptacle that is properly installed and grounded in accordance with ALL local codes and ordinances.

DO NOT MODIFY THE PLUG PROVIDED. If it will not fit the receptacle, have the proper receptacle installed by a qualified electrician.

IMPROPER CONNECTION of the equipment-grounding conductor can result in risk of electric shock. The conductor with green insulation (with or without yellow stripes) is the equipment-grounding conductor. If repair or replacement of the electric cord or plug is necessary, **DO NOT** connect the equipment-grounding conductor to a live terminal.

CHECK with a qualified electrician or service person if you do not completely understand the grounding instructions, or if you are not sure the tool is properly grounded.

Refer to nether picture:

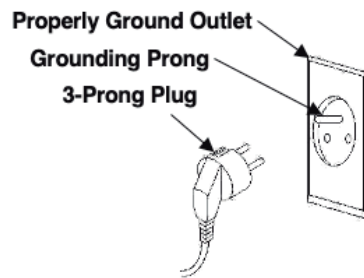

WARNING: Improper connection of equipment grounding conductor can result in the risk of electrical shock. Equipment should be grounded while in use to protect operator from electrical shock.

WARNING: This machine is for indoor use only. Do not expose to rain or use in damp locations.

GUIDELINES FOR EXTENSION CORDS

USE PROPER EXTENSION CORD. Make sure your extension cord is in good condition. When using an extension cord, be sure to use one heavy enough to carry the current your product will draw. An undersized cord will cause a drop in line voltage, resulting in loss of power and cause overheating.

Be sure your extension cord is properly wired and in good condition. Always replace a damaged extension cord or have it repaired by a qualified person before using it. Protect your extension cords from sharp objects, excessive heat and damp or wet areas.

ELECTRICAL CONNECTIONS

WARNING: Make sure unit is off and disconnected from power source before inspecting any wiring. The power lines are inserted directly onto the switch. The green ground line must remain securely fastened to the frame to properly protect against electrical shock.

4 Installation

4.1 Unpacking and Checking Contents

Carefully unpack the table saw and all its parts, and compare against the illustration following.

WARNING:

- To avoid injury from unexpected starting, do not plug the power cord into a power source receptacle during unpacking and assembly. This cord must remain unplugged whenever you are assembling or adjusting the machine.
- If any part is missing or damaged, do not plug the machine until the missing or damaged part is replaced, and assembly is complete.

TABLE OF LOOSE PARTS

Unpack carton; check you machine to see parts listed below:

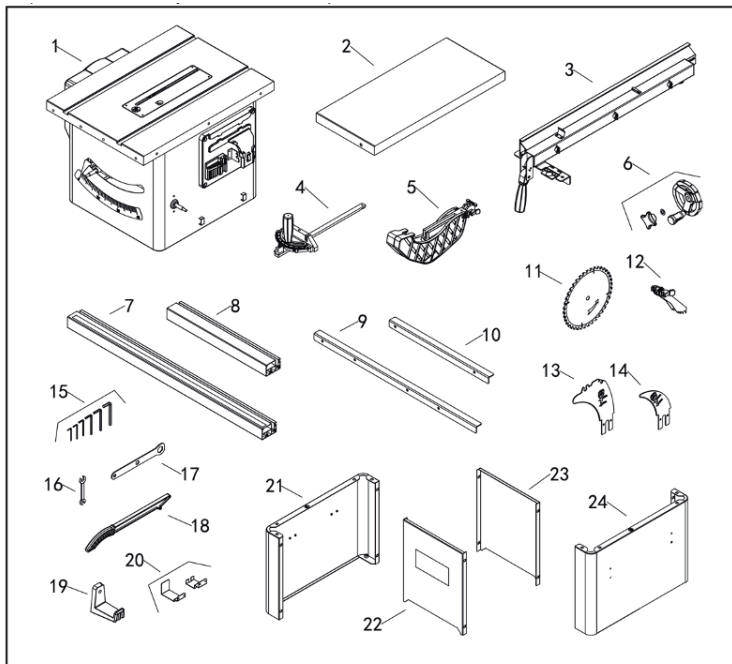

Item	Parts Name	Item	Parts Name
1	TABLE SAW	14	SMALL RIVING KNIFE
2	EXTENSION TABLE (2)	15	HEX WRENCH (6)
3	RIP FENCE ASSEMBLY	16	10-13MM WRENCH
4	MITER GAUGE ASSEMBLY	17	24MM WRENCH
5	BLADE GUARD ASSEMBLY	18	PUSH STICK
6	HANDWHEEL WITH KNOB (2)	19	RIP FENCE STORAGE HOOKS (2)
7	LONG FRONT RAIL	20	BLADE GUARD STORAGE HOOKS (2)
8	SHORT FRONT RAIL	21	LEFT STAND "A"
9	LONG REAR RAIL	22	FRONT BRACE WITH LABEL
10	SHORT REAR RAIL	23	REAR BRACE
11	BLADE	24	RIGHT STAND "B"
12	ANTI-KICKBACK PAWL ASSEMBLY	25	AAA BATTERY (2) (THE BATTERIES ARE USED FOR LASER. THEY WILL NOT BE SUPPLIED, IF YOUR TABLE SAW IS NOT SUPPLIED LASER)
13	RIVING KNIFE		

Hardware Bag #1 (For extension table assembly)

M10X25 Socket head bolt (6)

10mm Lock washer

10mm Flat washer

Hardware Bag #2 (For guide rail)

M8X25 Hex head bolt (6)

M8X25 Socket head bolt (6)

8mm Flat washer (18)

M8 Hex nut (12)

Hardware Bag #3

M8X16 Carriage bolt (16) (For assembling stand to main machine)

8mm Lock washer (16)

8mm Flat washer (16)

M6X20 Socket head screw (2) (For assembling fence storage hooks)

M4X8 Pan head screw (4) (For assembling blade guard storage hooks)

4mm Flat washer (4)

IMPORTANT: Table is coated with a protectant. To ensure proper fit and operation, remove coating. Coating is easily removed with mild solvents, such as mineral spirits, and a soft cloth. Avoid getting solution on paint or any of the rubber or plastic parts. Solvents may deteriorate these finishes. Use soap and water on paint, plastic or rubber components. After cleaning, cover all exposed surfaces with a light coating of oil. Paste wax is recommended for table top.

WARNING: Never use highly volatile solvents. Non flammable solvents are recommended to avoid

4.2 Assembly

CAUTION: Do not attempt assembly if parts are missing. Use this manual to order replacement parts. Be certain all parts are clean and free of shipping preservative. Also, completely remove all parts of packing. Saw cabinet should be directly on the floor.

SAW INSTALLATION

Positioning the saw on a level surface will improve stability and accuracy and prevent warpage and failure of cast components and welds.

WARNING: Make certain that the saw is disconnected from the power source.

INSTALL HANDWHEELS

Refer to following figure

- Remove saw cabinet from the carton box and place upside down on cardboard on floor.
- Place one of the handwheels onto the blade raise/lower shaft located on the front of the cabinet. Align the groove in the back of the handwheel with the pin.
- Thread the washer and locking knob onto the threaded end of the shaft.
- Repeat the steps above to assemble the remaining handwheel and locking knob onto the blade tilt shaft located on the side of the cabinet.

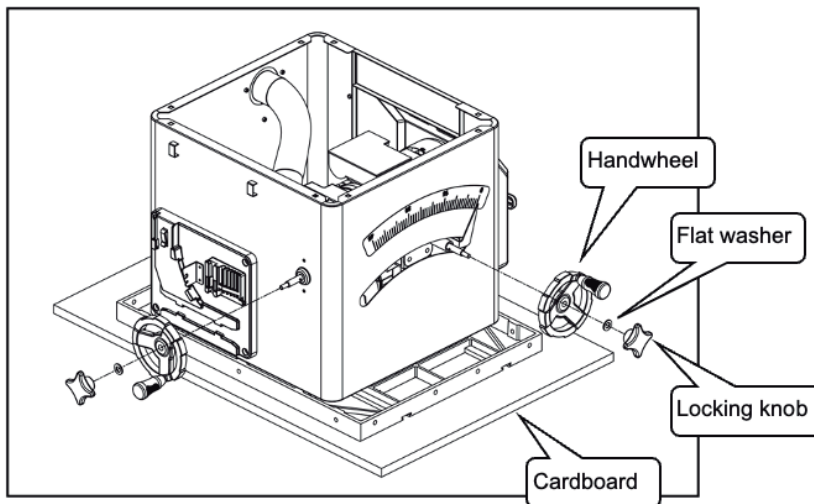
**REMOVE PACKING MATERIAL**

Refer to following figure

- Use the handwheel to raise the motor.
- Remove the packing material under the motor.

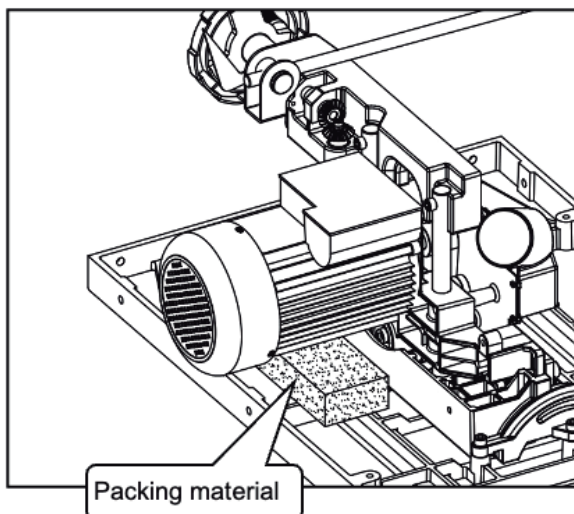

ASSEMBLE THE STAND BASE

Refer to following figure

Assemble the two side stands, front brace with label and rear brace together using 8 carriage bolts, flat washers and nuts.

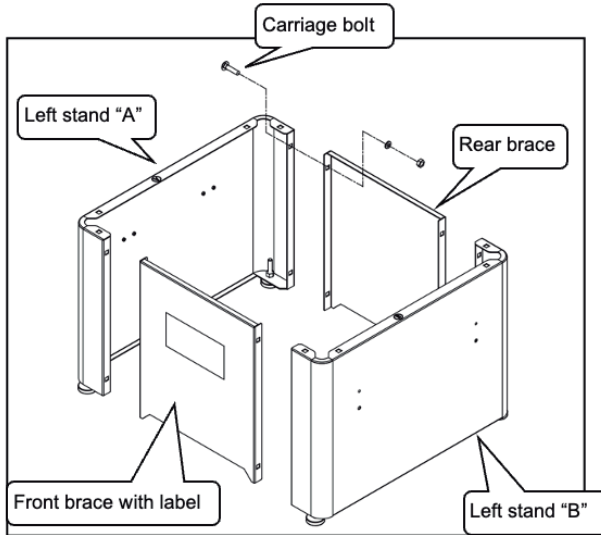

ATTACH STAND BASE TO CABINET

Refer to following figure

- Place the stand base assembly over cabinet.
- Secure stand base assembly using 8 carriage bolts, flat washers and nuts.

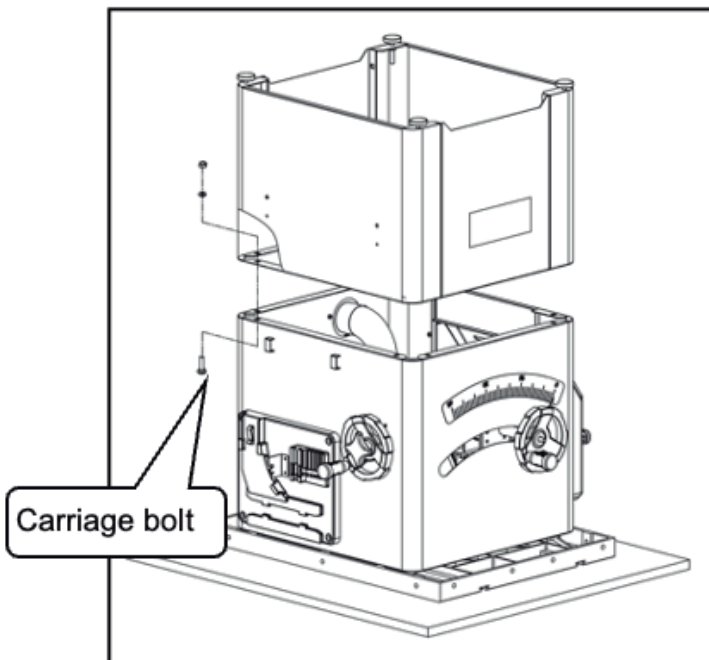

ATTACH EXTENSION TABLES

Refer to following figure

- With help of another person, place the table saw upright. Adjust the feet to make the table saw stand stably.
- With help of another person, Assemble extension table to the table using socket head bolts, lock washers and flat washers.
- If necessary, remove the left side cover to install the extension table and replace it after the installation.
- Wipe surface clean.
- Do not tighten completely until tables are level. Use a straightedge to level tables. If necessary, adjust the set screw to level the table.
- After tables are adjusted level and flat, secure the extension tables by tightening the bolts completely.
- Repeat above procedure for the other extension table.

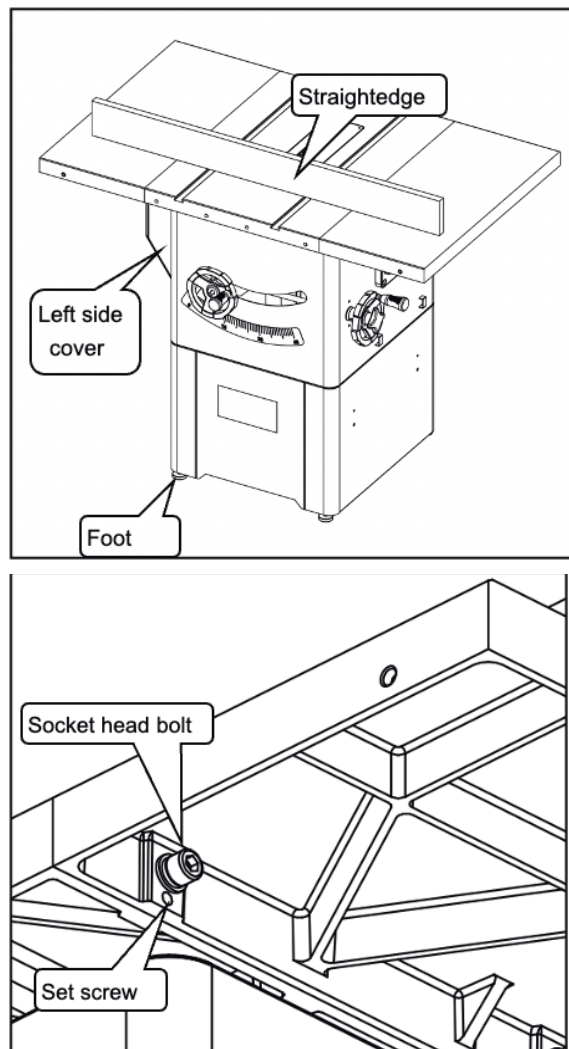

INSTALL BLADE

Refer to following figure

- Unlock the knob and remove the table insert.
- Raise blade assembly all the way up.
- Pull arbor lock and use wrench to loosen flange nut. Remove flange and nut from arbor.
- Place blade on arbor. Make sure arrow on blade and teeth point towards front of saw.
- Replace flange and nut on arbor and securely snug blade in position. Replace the table insert.

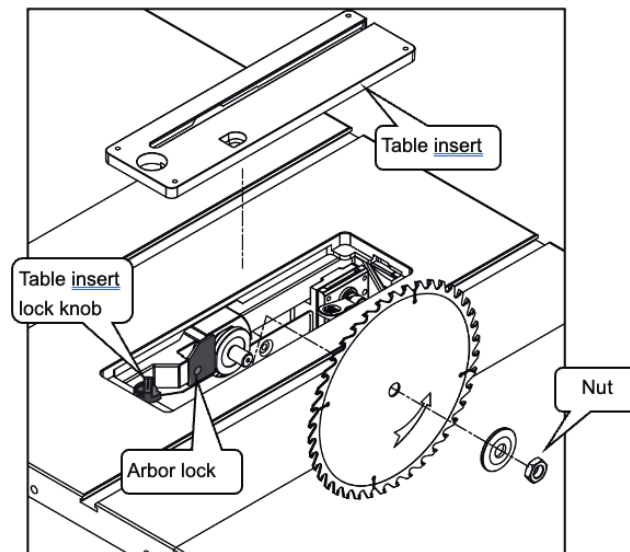

CHECK TABLE ALIGNMENT

Refer to following figure.

- Saws are shipped from the factory with the table adjusted so the miter gauge slots are parallel to the saw blade. However, in order to obtain the best results from the saw, it is suggested this adjustment be checked before operating.
- A simple method of checking alignment is as follows: Bolt or clamp a dowel rod or similar object to miter gauge (a combination square can be substituted). Pick out a tooth on front of blade and set the dowel to it so it is just touching. Move same tooth to back of blade.

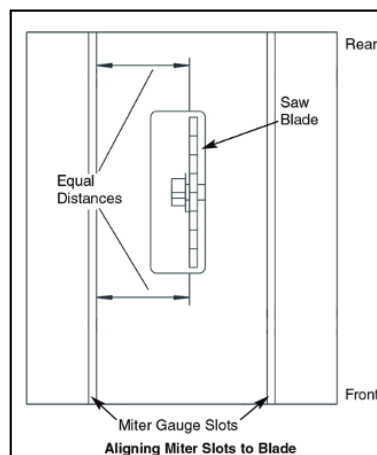

- Gauge this tooth with the dowel rod. If the tooth is in the same position, relative to the miter gauge slot, the table is parallel with the blade. In short, the miter gauge slots must be parallel with the blade. This means that when measuring distance between blade and miter gauge slot at the front and rear of the blade, the distances will be equal.

NOTE: Be sure to measure the distance or make the test on the same tooth of the saw blade in both front and rear positions.

RAIL ASSEMBLY

Refer to following figure.

- Insert four M8 x 25 hex head bolts into the T-slot of the right front guide rail.
- Attach right front rail to the table and right table extension using flat washers, and hex nuts.

NOTE: Hand tighten all hardware during rail assembly. Do not completely tighten hardware until all rails are mounted.

- Attach left front rail in the same manner.

NOTE: You may have to shift right rail as far right as it will go to attach left rail.

- Position rails so that rails are butted together and blade mark on the right rail is aligned with the blade. You may need a mallet to lightly tap rails together. Make sure rails are completely butted together at the joint.
- Check and make certain that front rail are parallel to the table surface. Then tighten the screws completely.
- Attach short and long rear rails to the table and table extension using M8X25 socket head bolts, flat washers, and hex nuts

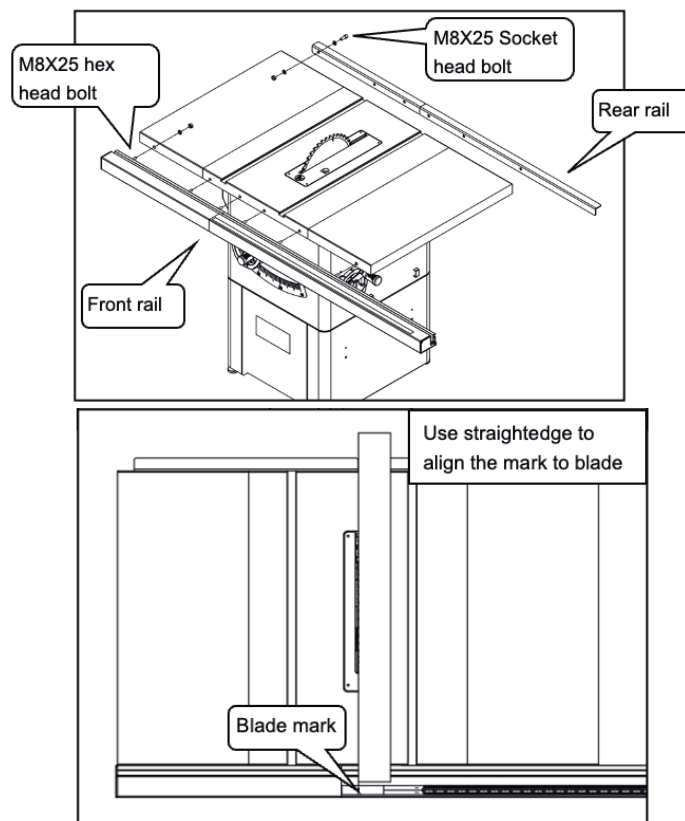

ATTACH SWITCH ASSEMBLY

Refer to following figure.

- Remove the cover from left front rail, Insert bolt heads into T-slot on bottom of left front rail. Replace the cover.
- Slide switch assembly 6" to 8" from left end of rail.
- Fully tighten flat washers, lock washers and hex nuts to secure switch assembly in place.

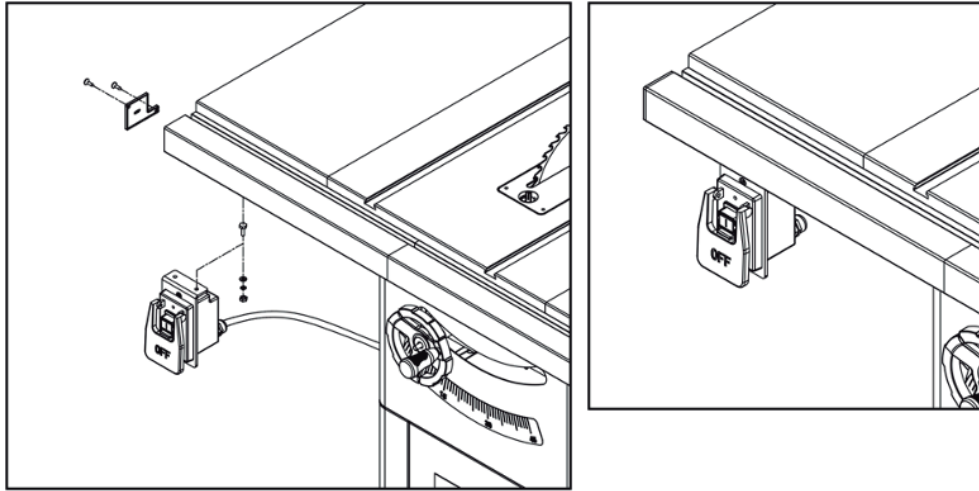
**POSITION AND ADJUST RIVING KNIFE**

Refer to following figure.

- Unlock and remove the table insert.
- Lift up the locking lever and install the riving knife .
- Make sure the pin is aligned with riving knife hole and press down the locking lever to secure riving knife in position. Replace the table insert.
- Riving knife must be in line with blade.

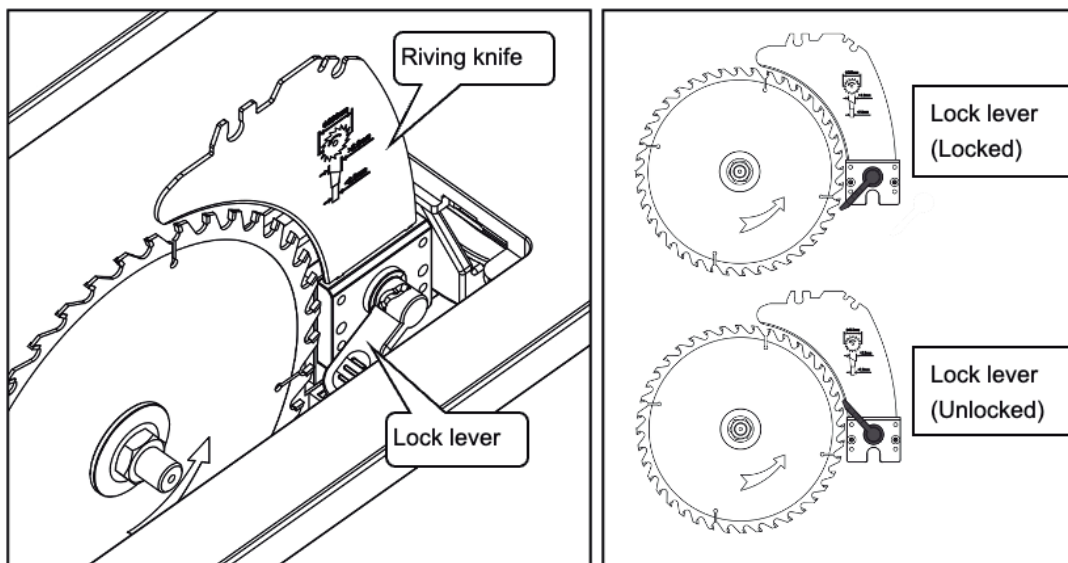

RIVING KNIFE TO BLADE ADJUSTMENT

The riving knife should be in line with the saw blade. If adjustment is necessary:

- Loosen the two socket pan head screws slightly.
- Adjust the set screws as needed to correct the out-of-align blade attachment. Do small adjustments and check.
- Once the riving knife is aligned with the blade, tighten the two socket pan head screws.

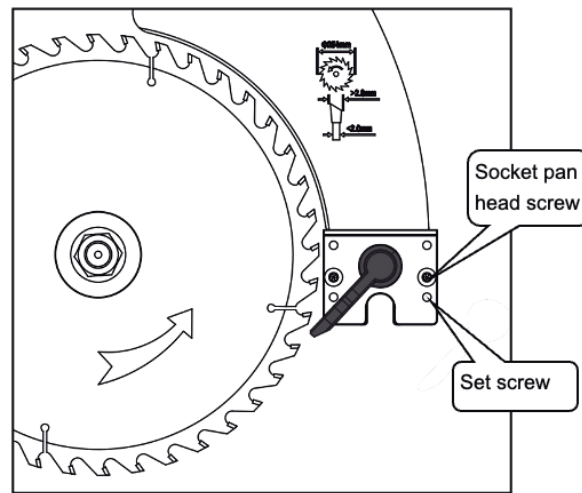
**RAIL ASSEMBLY**

Refer to following figure.

- Place table insert into throat of table and turn the knob to lock it
- To adjust insert level with table, adjust leveling screws up or down.

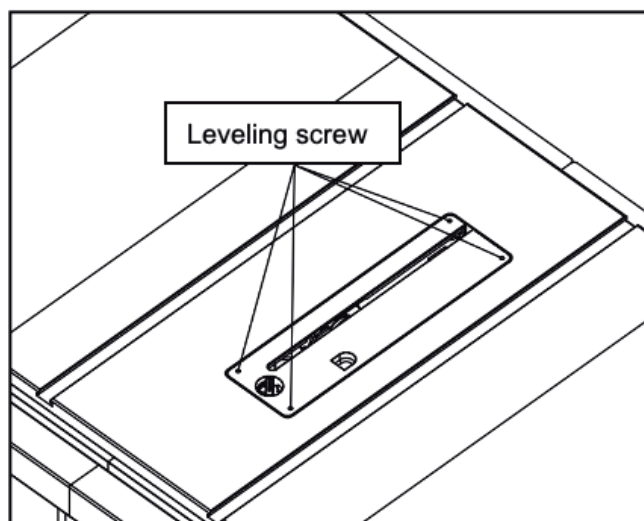

ATTACH SWITCH ASSEMBLY

Refer to following figure.

- Remove the thread forming screw and the battery cover. Insert the two AAA batteries and replace the battery cover and thread forming screw.

The laser is an optional accessory. If your machine has not this part, skip this step.

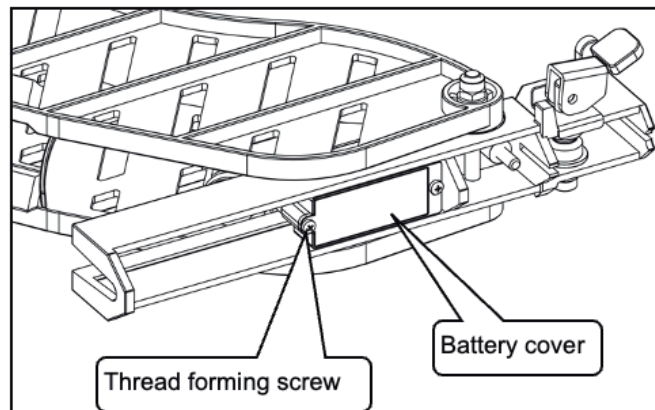

- Place the slot of blade guard body over the riving knife. Slot of bushing is placed in the notch indicated in following figure.
- The bushings have a beveled edge and must be located in the center of the notch to lock properly.
- Position guard completely down on riving knife and press latch to lock in position.
- Blade guard body should be parallel to the table. If not, adjust the 2 set screws as necessary.
- Place anti-kickback pawl set onto riving knife at notches indicated. The spring pin is placed in the front notch and bolt is placed in the rear notch.
- Press pawl set completely down and press latch to secure in position.

NOTE: The teeth of anti-kickback pawls should touch table surface. Use set screws to adjust if needed.

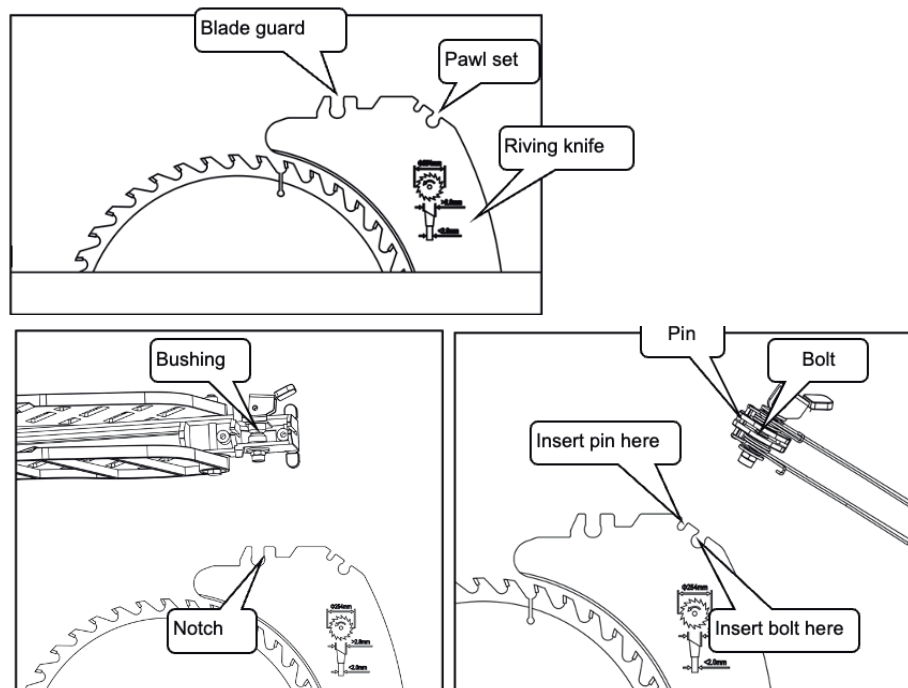

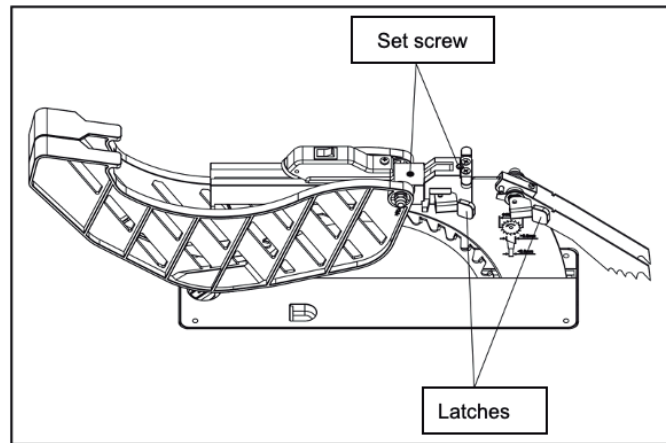

CHECK AND ADJUST THE LASER

The laser is an optional accessory. If your machine has not this part, skip this step.

- Turn on the switch, check if the laser line is in the middle of the blade and blade mark. If not, some adjustments are needed. (The blade mark should have been aligned with blade)
- To adjust the laser line:
- Loosen the two set screw.
- Move and rotate the laser generator to adjust the laser line, make it is in the middle of the blade and blade mark. Retighten the two set screw.

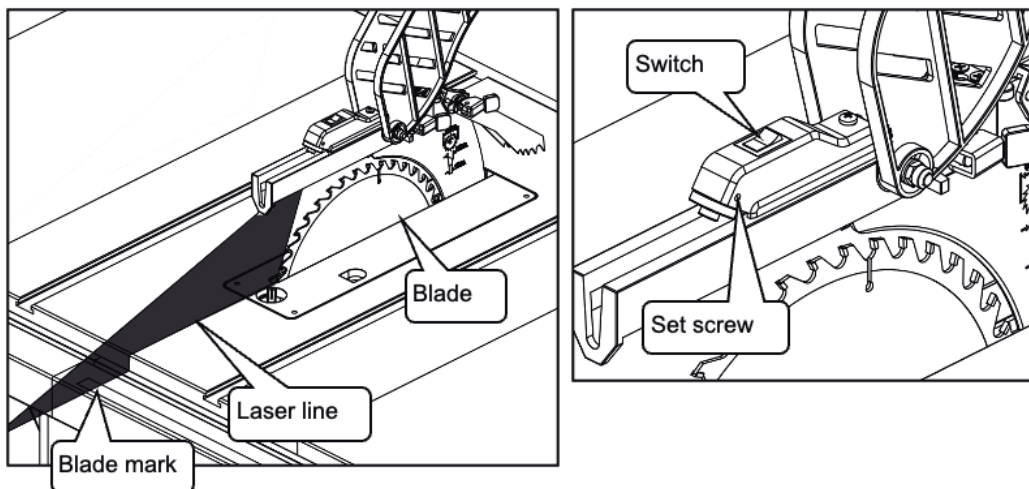

BLADE GUARD AND RIP FENCE STORAGE BRACKETS

Refer to following figure.

- Install the blade guard storage brackets to the left stand using four M4X8 pan head screws and flat washers.
- Install the rip fence storage brackets to right stand using two M6X20 socket head bolts.

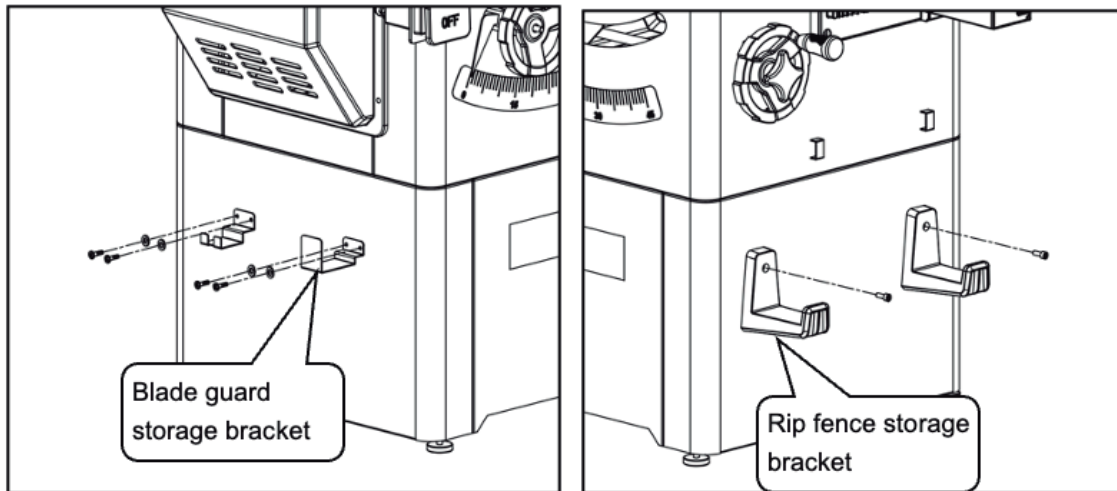

INSTALL RIP FENCE

Refer to following figure.

- Place rip fence assembly onto rails.
- Rip fence should ride freely on rails. Once rip fence is completely installed, it should be parallel with the miter gauge and perpendicular to the table. If not, refer to “Rip Fence Adjustment” in the Operation section of this manual.

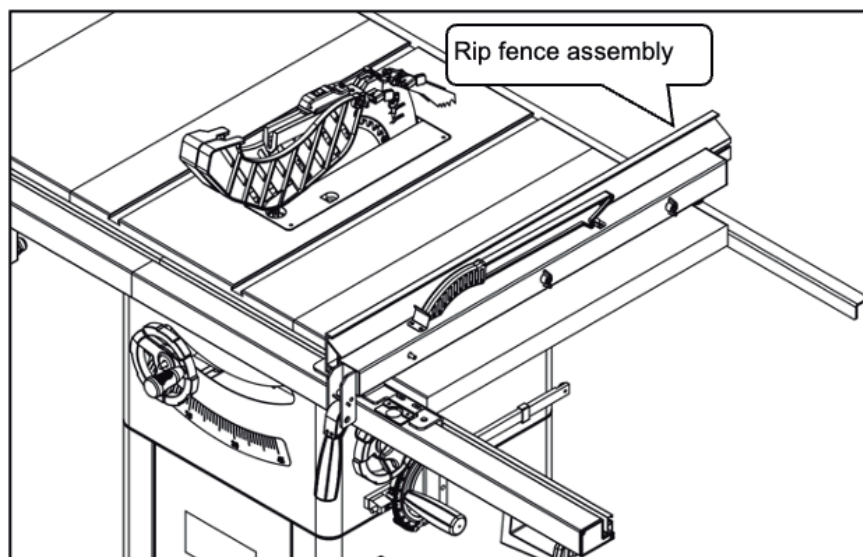

STORE BLADE GUARD, MITER GAUGE, RIP FENCE AND OTHER PARTS

Refer to following figure.

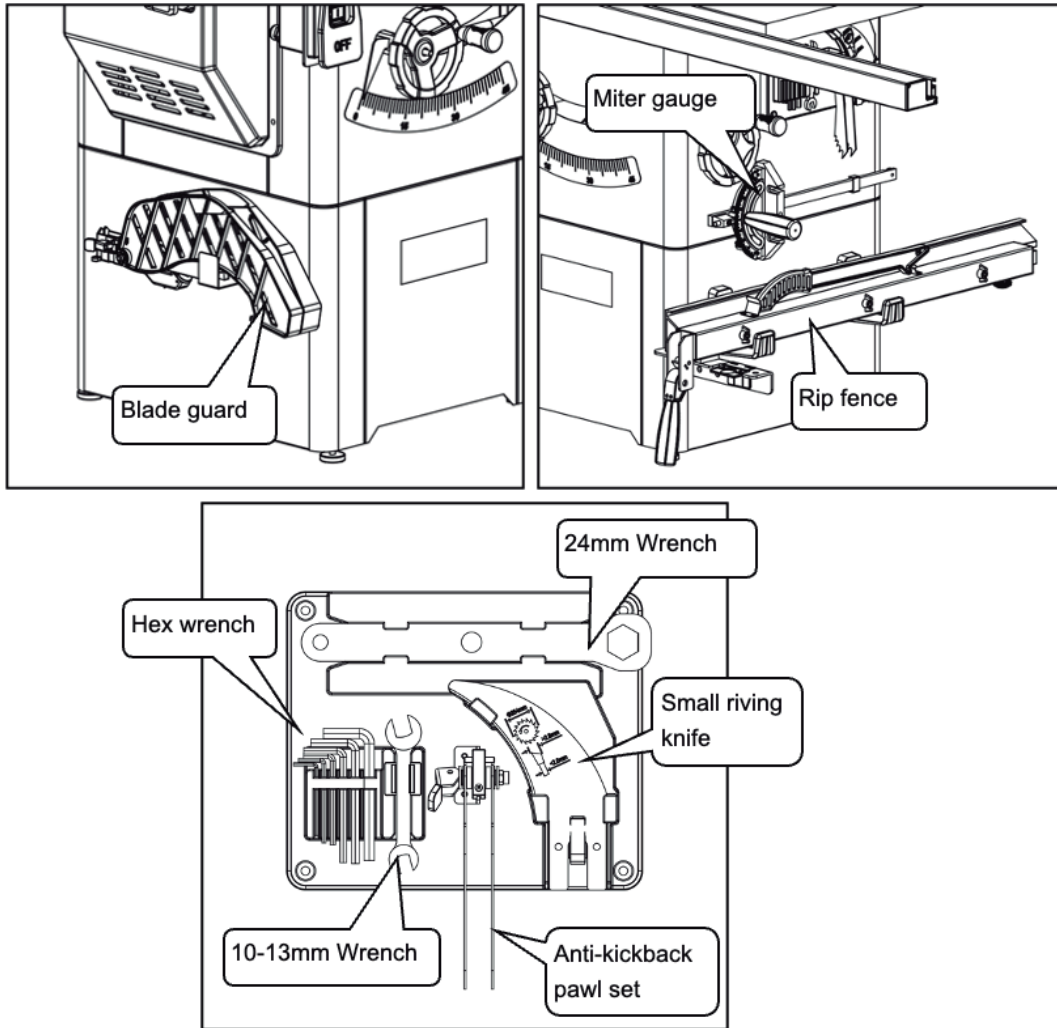

5 Operating Procedures

5.1 Description

The 10" contractor saw offers precise cutting performance for all woods up to 3-1/8" thick. The saw is designed for the professional user and is ruggedly constructed for continuous service. The 10" Saw is recommended for use with a 10" blade.

The saw features an extra large cast iron table. Saw body has on board storage for miter gauge and rip fence. Saw is equipped with a riving knife and a clear acrylic blade guard with anti-kickback feature. Cabinet is constructed of heavy gauge welded steel, totally enclosed and is ported for a 4" vacuum hose.

Rip Fence Assembly features a heavy-duty precision rip fence that is designed for simple and one-hand maneuverability. Front rail is calibrated in inches and millimeters with a magnified window for close tolerances.



Warning! Danger – Disconnect power before attempting any of the following procedures. Be certain switch is in OFF position and safety disconnect (or breaker) is in OFF or open position. Saw blade must not be moving. Saw blade will rotate freely after motor is turned off. Allow blade to come to a complete stop before attempting any of the following procedures.



Warning! The operation of any power tool can result in foreign objects being thrown into the eyes, which can result in severe eye damage. Always wear safety goggles complying with the standard of your country before commencing power tool operation.

5.2 Starting and Stopping the Saw

Refer to following figure.

WARNING: Never operate saw without blade guards in place. Be sure blade is not in contact with workpiece when motor is started. Start motor and allow saw to come to full speed.

WARNING: Make sure the electrical characteristics of motor nameplate and power source are the same.

- The ON/OFF switch is located under the front rail of the table saw at the left side.
- To turn saw on, stand to either side of the blade—never inline with it. Turn on the switch. Always allow saw blade to come up to full speed before cutting.
- Do not turn motor switch ON and OFF rapidly. This action overheats the motor and may cause saw blade to loosen.
- Never leave saw while the power is on.
- To turn the table saw off, press the large red OFF paddle or turn off the switch. Never leave saw until cutting tool has come to a complete stop.

WARNING: For your own safety, lower blade or cutting tool below table surface. If blade is tilted, return it to vertical position. Turn off safety disconnect or circuit breaker when saw is not in use.

5.3 Adjustment

BLADE HEIGHT ADJUSTMENT

Refer to following figure.

- Blade height is controlled by handwheel on the front of the saw.
- To adjust height, loosen locking hand knob. Rotate knob counterclockwise approximately three turns. Turn handwheel to desired blade height.

CAUTION: For safety, blade should be raised only 1/8" above the surface of the material to be cut. However, if hollow ground blades are used, raise blade to its maximum height to allow for greater blade clearance.

- Lock blade height into position. Lock handwheel by tightening locking knob clockwise. Tighten only until snug.

IMPORTANT: Do not over tighten. Only a small amount of pressure is necessary to lock handwheel securely.

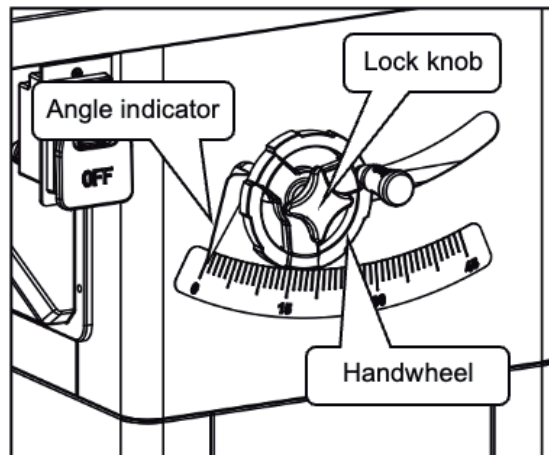

BLADE TILT ADJUSTMENT

Refer to following figure.

- The saw blade can be set at any angle between 90° and 45°. Blade tilt is controlled by the handwheel on the right side of the saw. The indicator on front of saw shows the tilt angle of the blade.
- To adjust tilt, loosen locking hand knob. Rotate knob counterclockwise at least three turns. Turn handwheel to desired blade angle. Lock blade angle into position.
- Lock handwheel by tightening locking hand knob clockwise. Tighten only until snug.
- The saw is equipped with positive stops at 90° and 45°.

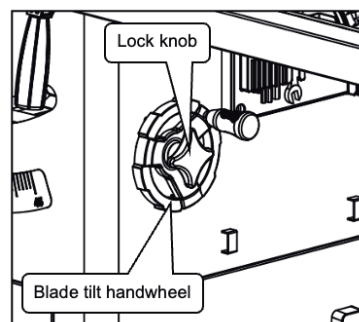

MITER GAUGE ADJUSTMENT

Refer to following figure.

- Miter gauge supplied with saw is equipped with individually adjustable index stops at 0° and 45°, right and left, and can be manually adjusted up to 60° right and left. Adjustment to index stops can be made by loosening locking nut and tightening or loosening three adjusting screws. Be sure to tighten locking nut after adjustment is made.
- Face of miter gauge has two holes for purpose of attaching auxiliary facing.
- Miter gauge is accurately constructed for precision work. Miter gauge is guided through T-slot with a roller guide mounted at front of guide bar. Roller guide adds to miter gauge's stability and prevents the guide bar from leaving T-slot.
- To operate miter gauge, simply loosen locking knob and move miter gauge to desired angle. The miter gauge will stop at 0° and 45°, both right and left. To position miter gauge past these points, simply pull out gauge stop. Position miter gauge at desired angle and tighten locking knob.
- Be positive the edge of workpiece next to face of miter gauge is straight and tight against miter gauge so that the workpiece does not rock or rotate. Always use both hands when operating the miter gauge.
- The miter gauge is used for cross-cutting, compound miter cutting, miter cutting, rabbeting, bevel cutting and dadoing.

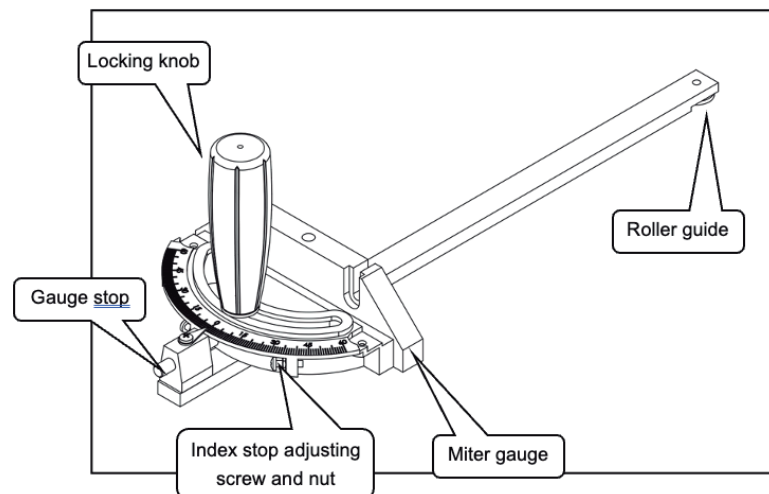

RIP FENCE ADJUSTMENT

The saw's rip fence is precision manufactured, incorporating fine adjustments for accurate cuts. The saw is built to allow the operator to accurately adjust the rip fence without problems in a matter of seconds.

SETTING FENCE PERPENDICULAR AND PARALLEL

Refer to following figure.

PERPENDICULAR ADJUSTMENT

- Position fence anywhere on table and lock it down.
- Place a square on the table next to the fence and check to see that the fence is at 90° to the table.
- If an adjustment is necessary, unlock the fence and turn either of the two adjusting screws.

NOTE: This is for micro-adjustment only. If fence cannot be adjusted square, recheck rail adjustment.

- Lock fence in position and recheck. Continue this procedure until fence is square to the table.

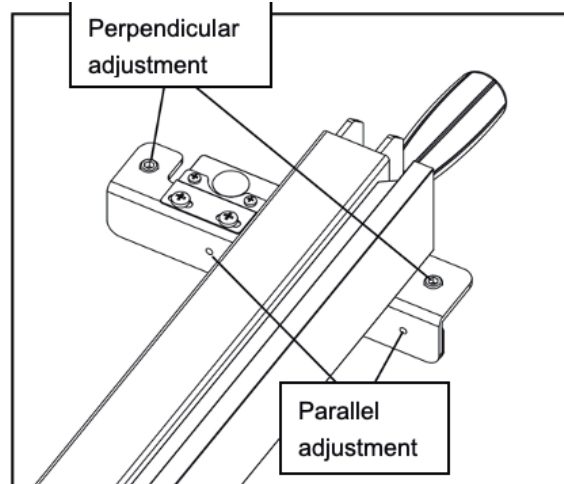

PARALLEL ADJUSTMENT

- Position fence so that fence edge is aligned with slot edge.
- Slot and fence edge should be parallel.
- If an adjustment is necessary, unlock the fence and turn either of the two adjusting screws.
- Lock fence in position and recheck. Continue this procedure until fence is square to the table.

CURSOR ADJUSTMENT

Refer to following figure.

- Raise the saw blade above the table.
- Position the fence several inches to the right of the saw blade.
- Lock the fence down and measure the exact distance between the saw blade and the inside of the fence.
- Loosen the two screws on the lens and slide it left or right until the cursor (red line) equals the measurement obtained in the previous step.
- Retighten the screws and make a test cut. Measure the cut piece to verify that the cursor is set correctly.

NOTE: This adjustment should be checked whenever a new blade is installed.

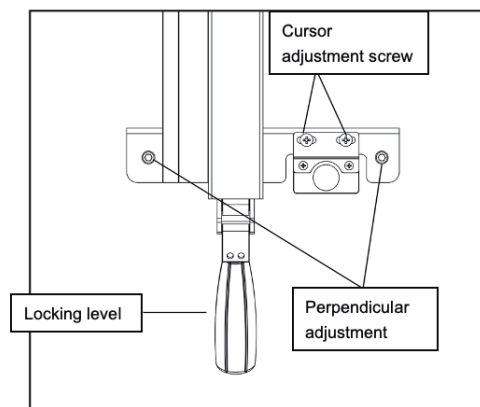

RIP FENCE OPERATION

- Unlock the fence by lifting the locking lever. Using the scale for placement, position the rip fence. Lock the rip fence into position by placing the locking lever in the down position.
- The rip fence is used for the following operations: ripping, bevel ripping, ploughing, resawing, rabbeting and dadoing.

WARNING: For your own safety, always observe the following safety precautions.

- Never make any cut freehand (without using miter gauge or rip fence). Blade can bind in the cut and cause a kick-back.
- Always lock miter gauge or rip fence securely when in use.
- Remove rip fence from the table when miter gauge is in use.
- Remove miter gauge from table when rip fence is in use.
- Make sure blade guard is installed for all “through sawing” operations. Through sawing operations are those operations in which the saw blade cuts completely through the thickness of the wood. Replace guard immediately after completion of resawing, rabbeting and dadoing. Frequently check action of anti-kickback pawls by passing the workpiece alongside the spreader while saw is off. Pull the workpiece toward you. If the pawls do not dig into the workpiece and hold it, the pawls must be sharpened. (See Maintenance section)
- Have blade extend approximately 1/8" above top of workpiece. Additional blade exposure increases hazard potential.
- Do not stand directly in front of blade in case of a kick-back. Stand to either side of the blade.
- Keep your hands clear of the blade and out of the path of the blade.
- If the blade stalls or stops while cutting, turn switch OFF and safety disconnect OFF before attempting to free the blade.
- Do not reach over or behind the blade to pull the work-piece through the cut, to support long or heavy work-pieces, to remove small cut-off pieces of material or for any other reason.
- Do not pick up small pieces of cut-off material from the table. Remove them by pushing them off table with a long stick. Otherwise they could be thrown back at you by the rear of the blade.
- Do not remove small pieces of cut-off material that may become trapped inside blade guard while saw is on. This could endanger your hands or cause a kickback. Turn saw off. After blade has stopped turning, lift guard and remove the piece.
- Always lower blade below the table level when machine is not in use.

5.4 Types of Cuts/Operations

CROSSCUTTING

WARNING: Use caution when starting the cut to prevent binding of the guard against the workpiece.

This cut is performed with the miter gauge set at “0”, and is used for cutting across the workpiece grain at 90° (blade square with both the edge and flat side of wood).

MITER CUTTING

WARNING: Miter angles greater than 45° may force the blade guard assembly into the saw blade causing damage

to the blade guard assembly and personal injury. Before starting the motor, test the operation by feeding the workpiece into the blade guard assembly. If the blade guard assembly contacts the blade, place the workpiece under the blade guard assembly, not touching the blade, before starting the motor.

WARNING: Certain workpiece shapes, such as molding may not lift the blade guard assembly properly. With the power off, feed the workpiece slowly into the blade guard area and until the workpiece touches the blade. If the blade guard assembly contacts the blade, place the workpiece under the blade guard assembly, not touching the blade, before starting the motor.

This cut is performed with the miter gauge, and is used for cutting at an angle other than 90° square with the edge of the workpiece.

BEVEL CROSSCUTTING

WARNING: When possible, use the right miter gauge slot when bevel crosscutting so that the blade tilts away from the miter gauge and your hands.

WARNING: Use caution when starting the cut to prevent binding of the guard against the workpiece.

This cut is performed with the miter gauge, and is the same as crosscutting, except that the workpiece is also cut at an angle other than 90° square to the flat side of the wood (blade is at an angle).

COMPOUND MITER CUTTING

This cut is performed with the miter gauge, and is a combination of miter cutting and bevel crosscutting. The cut is made at angle other than 90° to both the edge and flat side of wood.

RIPPING

WARNING: When bevel ripping and whenever possible, place the fence on the side of the blade so that the blade is tilted away from the fence and hands. Keep hands clear of the blade and use a push stick to feed the workpiece if there is less than 6" between the fence and the blade.

This cut is performed with the rip fence, and is used to cut the workpiece lengthwise with the grain. Position the fence to the desired width of rip and lock in place. When ripping long boards or large panels, always use a work support.

BEVEL RIPPING

WARNING: Before connecting the table saw to the power source or operating the saw, always inspect the blade guard assembly and riving knife for proper alignment and clearance with saw blade. Check alignment after each change of bevel angle.

WARNING: When possible, place the fence on the right side of the blade so that the blade is tilted away from the fence and hands. Keep your hands clear of the blade and use a push stick to feed the workpiece if there is less than 6" between the fence and the blade.

This cut is performed with the rip fence, and is the same as ripping, except that the blade is set at an angle other than 90°.

RESAWING

This cut is performed with the rip fence, and is used to rip a workpiece through its thickness rather than across its flat width. Do not attempt to resaw bowed or warped material.

NOTE: It may be necessary to remove blade guard and use work supports as well as push blocks when performing this operation.

WARNING: Install blade guard immediately upon completion of resawing operation.

PLOUGHING

This cut is performed with the rip fence, and is used to make a groove lengthwise with the grain of the workpiece. Use proper hold downs and feed devices.

RABBETING

This cut is performed with either the miter gauge or rip fence. Rabbeting is used to cut out a section of the corner of a workpiece, across an end or along an edge. To make a rabbet requires cuts which do not go all the way through the material. Therefore, blade guard must be removed. Install blade guard immediately upon completion of rabbeting operation. Rabbet cuts can also be made using dado head.

DADOING

This cut is performed with either the miter gauge or rip fence. Dadoing is done with a set of blades (dado set) rather than standard saw blades. The dado set is used to groove wood similar to ploughing and rabbeting. However, the dado set allows operator to remove more material in one pass. The operator, with a dado set, can vary width of cut up to 13/16".

Instructions for operating dado set are contained in owner's manual furnished with dado set. Dadoing requires cuts which do not go all the way through material. Therefore, blade guard must be removed. Dado sets have different characteristics than saw blades. As a result, saw must be fitted with special parts that are furnished with saw.

When using a dado set, the following parts must be substituted dado table insert (not included).

IMPORTANT: Always use correct insert. When using the dado set, use caution. Use feather boards and push sticks as applicable.

WARNING: Always immediately replace the standard blade, blade guard and blade insert when you are finished dadoing.

FREEHAND

Freehand is a very dangerous operation of making a cut with-out using the miter gauge or rip fence. Freehand cuts must never be performed on a Table Saw.

CUTTING OVERSIZED WORKPIECES

When cutting long workpieces or large panels, always support workpiece that is not on table. Use adjustable roller stand or make simple support by clamping a piece of plywood to sawhorse. Add facings to miter gauge or rip fence as needed.

IMPORTANT: Do not allow facings to interfere with operation of blade guard.

DUST COLLECTING

- Saw is fitted with a 4" male exhaust port.
- Before starting saw, see that all adjustments are properly made and guards in place. With power disconnected, turn pulley by hand to make sure everything is correct before connecting power and starting saw.
-

BLADE SELECTION

Blade selection is based on type of material being cut and how it will be cut. There are three general types of saw blades: rip saw blades cut with grain of wood, cut-off saw blades cut across grain, and combination saw blades cut with grain, across grain and any angle to grain.

Blades vary in many aspects. When selecting a blade, the following blade characteristics should match up with operation to be performed and type of material to be cut: type of steel; quality of steel; tooth style; tooth set; carbide tipped; grind; number of teeth and size.

IMPORTANT: Your saw is only as accurate and efficient as blade or cutting tool used.

First, be certain to use the appropriate type of cutting tool for the operation to be performed. Second, it is strongly recommended that high-quality blades and cutting tools be used. Be certain blades and cutting tools are kept sharp and in good working order. Check blades periodically and replace or sharpen if necessary.

6 Maintenance

6.1 Safety instructions



Warning! Risk of injury: improper maintenance can cause serious injury or damage. For this reason, this work may only be carried out by authorised, trained personnel who are familiar with how to operate the machine and in strict observance of all safety instructions.

- Before beginning any maintenance work on the machine, switch it off and secure it against accidentally being switched on again.
- Ensure that there is sufficient space to work around the machine.
- Keep the work area orderly and clean. Components and tools that are not put in their correct place or put away may be the cause of accidents!



Warning! Danger – Do not attempt under any circumstances, to service, repair, dismantle, or disassemble any mechanical or electrical components without physically disconnecting all power sources.

6.2 Cleaning

- Clean off any preservative on bright (machined) parts with appropriate solvent (mineral spirits). Avoid getting cleaning fluid on any rubber parts as they tend to deteriorate rubber.
- Use soap and soft water on rubber and plastic parts.
- After cleaning, lubricate unpainted surfaces with a light application of medium consistency machine oil. This lubrication should be repeated at least once every six months.

NOTE: Instead of oil, a good quality paste wax can be applied to rip fence and table surface. Paste wax will enhance movement of workpieces. In addition to providing lubrication, paste wax will help prevent rusting.

- Keep your machine and your workshop clean. Do not allow sawdust to accumulate on saw or inside cabinet. Frequently vacuum or blow out any sawdust that may accumulate within cabinet.
- Be certain motor and internal mechanisms are clean and are frequently vacuumed or blown free of any dirt.

6.3 Lubrication

All bearings on the arbor are shielded ball bearings. These bearings are permanently lubricated at the factory.

- As needed, clean the grease off the rack and worm gears of height and tilt mechanism. Lubricate rack and gears with a medium viscosity machine oil.
- Be sure to lubricate trunnion ways and all bushings.
- Occasionally oil all other bearing points, including blade guard assembly, miter gauge and rip fence.

6.4 Service

- Replace belts and worn parts as needed. If power cords are worn, cut, or damaged in any way, have them

replaced immediately.

- Make sure teeth of anti-kickback pawls are always sharp.
- Sharpen dull teeth using a few light strokes of a smooth cut flat file.

6.5 Changing the Saw Blade

Refer to following figure.

WARNING: Turn the power switch "OFF" and unplug the power cord from its power source when changing the saw blade.

WARNING: When replacing blades, check the thickness stamped onto the riving knife. You must select a blade with a kerf width larger than the thickness of the riving knife. Thinner blades may cause the workpiece to bind during cutting.

WARNING: USE ONLY 10" diameter blades with 5/8" arbor holes, rated at or higher than 3800 R.P.M.

- Remove blade guard assembly and pawl assembly.
- Remove the table insert.
- Unlock the raise/lower handwheel lock and raise saw blade to maximum height.
- Pull out the arbor lock and hold arbor in locked position.
- Place supplied 24mm wrench on the arbor nut. Turn wrench counterclockwise to loosen nut. Remove arbor nut, blade flange and saw blade.
- Place new blade on arbor. Make sure saw blade teeth point down at the front side of saw table. Place flange and nut on arbor and securely snug blade in position.
- Replace table insert.
- Replace blade guard assembly and pawl assembly.

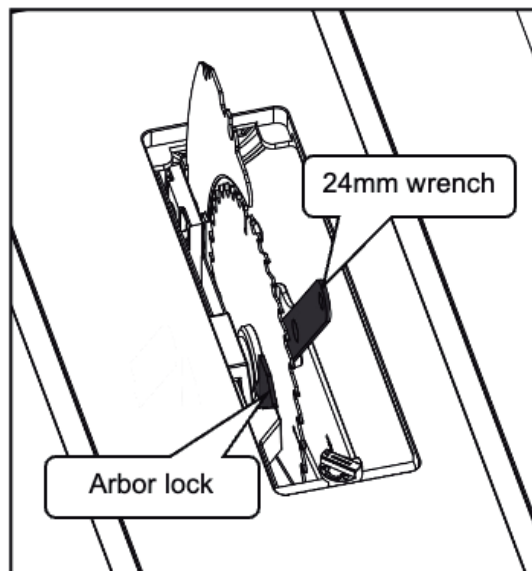

7 Troubleshooting

SYMPTOM	POSSIBLE CAUSE(S)	CORRECTIVE ACTION
Saw stops or will not start	<ol style="list-style-type: none"> 1. Overload tripped 2. Saw unplugged from wall or motor 3. Fuse blown or circuit breaker tripped 4. Cord damaged 5. Defective capacitor 	<ol style="list-style-type: none"> 1. Allow motor to cool and reset by pushing reset switch 2. Check all plug connections 3. Replace fuse or reset circuit breaker 4. Replace cord 5. Replace capacitor
Excessive vibration	<ol style="list-style-type: none"> 1. Stand on uneven floor 2. Damaged saw blade 3. Bad drive V-belts 4. Bent pulley 5. Improper motor mounting 6. Loose hardware 7. Loose set screw in pulley 	<ol style="list-style-type: none"> 1. Reposition on flat, level surface 2. Replace saw blade 3. Replace drive V-belts 4. Replace pulley 5. Check and adjust motor 6. Tighten hardware 7. Tighten set screw
Cannot make square cut when crosscutting	Miter gauge not adjusted properly	Adjust miter gauge
Blade stalls (however, motor turns)	<ol style="list-style-type: none"> 1. Drive belts not tight 2. Drive belts worn 	<ol style="list-style-type: none"> 1. Adjust drive belt tension 2. Replace drive belts
Blade does not come up to speed	<ol style="list-style-type: none"> 1. Extension cord too light or too long 2. Low shop voltage 3. Motor not wired for correct voltage 	<ol style="list-style-type: none"> 1. Replace with adequate size cord 2. Contact your local electric company 3. Refer to motor junction box
Cut binds, burns or stalls when ripping	<ol style="list-style-type: none"> 1. Dull blade with improper tooth set 2. Blade is binding at one end of cut (heeling) 3. Warped board 4. Rip fence not parallel to blade 5. Riving knife out of alignment 6. Excessive feed rate 	<ol style="list-style-type: none"> 1. Sharpen or replace blade 2. Adjust table and rip fence parallel to blade 3. Make sure concave or hollow side is facing down; feed slowly 4. Adjust rip fence 5. Adjust riving knife to fall in line with blade 6. Reduce feed rate
Cut not true at 45 or 90° positions	Positive stops not properly adjusted	Adjust blade tilt
Tilt and elevating handwheel difficult to turn	<ol style="list-style-type: none"> 1. Sawdust on rack and worm gears 2. Bushings and bearing surfaces dirty 	<ol style="list-style-type: none"> 1. Clean and relubricate 2. Clean thoroughly and lubricate
Rip fence binds on guide tube	<ol style="list-style-type: none"> 1. Guide rails or extension wing not properly installed 2. Guide of rip fence not adjusted properly 	<ol style="list-style-type: none"> 1. Reassemble guide rails 2. Adjust guides

SYMPTOM	POSSIBLE CAUSE(S)	CORRECTIVE ACTION
Frequent opening of fuses or circuit breakers	<ol style="list-style-type: none"> 1. Motor overloaded 2. Fuses or circuit breakers do not have sufficient capacity 	<ol style="list-style-type: none"> 1. Feed work slower into blade 2. Install proper size fuses or circuit breakers
Material kicked back from blade	<ol style="list-style-type: none"> 1. Rip fence out of alignment 2. Riving knife not aligned with blade 3. Feeding stock without rip fence 4. Riving knife not in place 5. Dull blade 6. Letting go of material before it is past blade 7. Anti-kickback fingers dull 	<ol style="list-style-type: none"> 1. Align rip fence with miter slot 2. Align riving knife with blade 3. Always use rip fence or miter gauge 4. Install riving knife 5. Replace blade 6. Push material all the way past blade before releasing work 7. Replace or sharpen anti-kickback fingers
Saw makes unsatisfactory cut	<ol style="list-style-type: none"> 1. Dull blade 2. Blade mounted backwards 3. Gum or pitch on blade 4. Incorrect blade for cut 5. Gum or pitch on table 	<ol style="list-style-type: none"> 1. Sharpen or replace blade 2. Turn blade around 3. Remove blade and clean 4. Change blade to correct type 5. Clean table

8 Exploded View

PART A

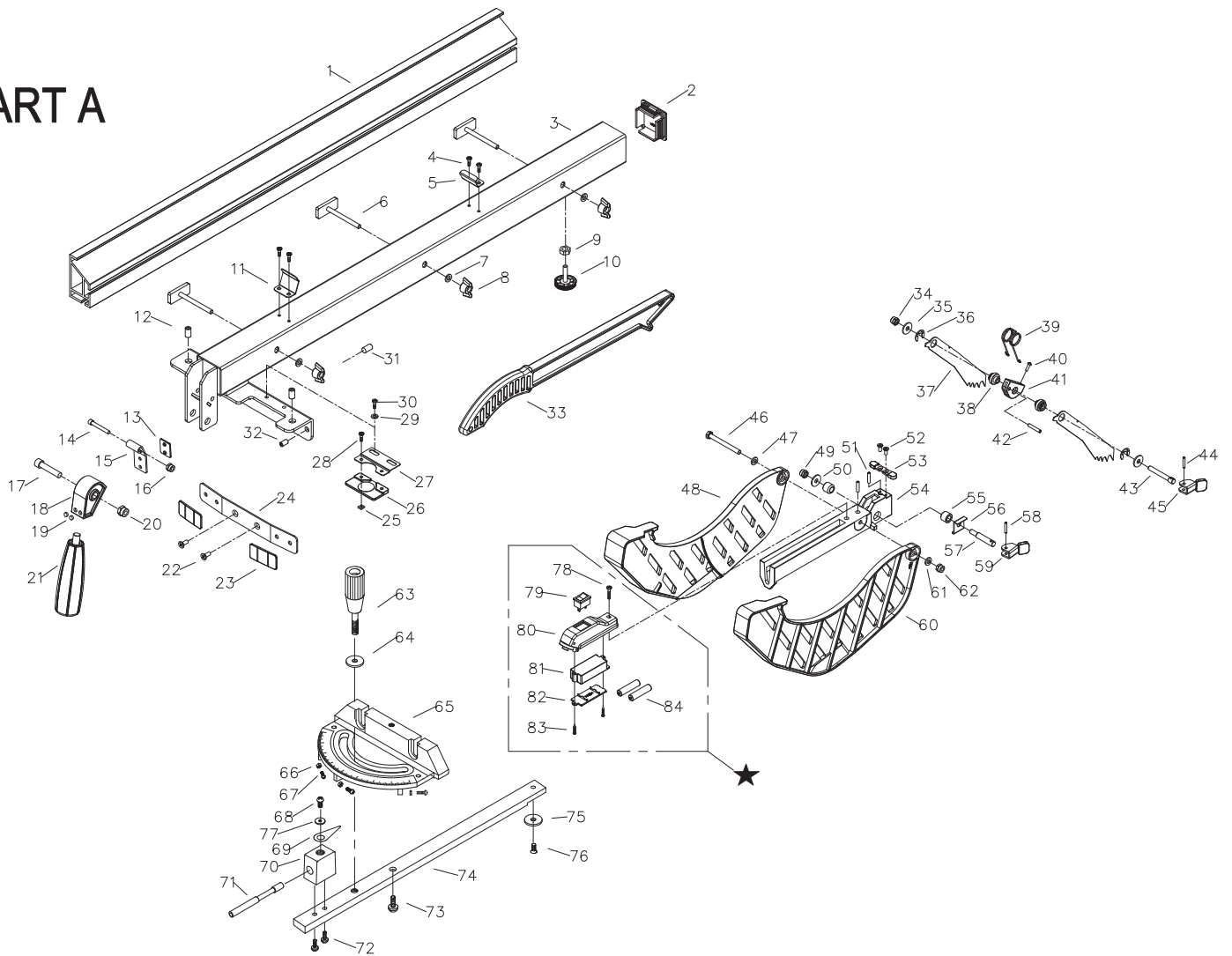

Part A

PARTS NUMBER	ITEM	PARTS NAME	QTY
SPMAK-SCX-A01	1	FENCE	1
SPMAK-SCX-A02	2	END CAP FOR FRAME	1
SPMAK-SCX-A03	3	FENCE SEAT FRAME	1
SPMAK-SCX-A04	4	5-0.8X10 PAN HEAD SCREW	4
SPMAK-SCX-A05	5	SPRING PIECE FOR HOLDING PUSH STICK	1
SPMAK-SCX-A06	6	FENCE SLIDING LOCK PLATE	3
SPMAK-SCX-A07	7	FLAT WASHER	3
SPMAK-SCX-A08	8	KNOB	3
SPMAK-SCX-A09	9	6-1.0 HEX NUT	1
SPMAK-SCX-A10	10	REAR SUPPORT KNOB	1
SPMAK-SCX-A11	11	SPRING PIECE FOR HOLDING PUSH STICK	1
SPMAK-SCX-A12	12	PLASTIC SET SCREW	2
SPMAK-SCX-A13	13	PLASTIC PAD ON BENDING PLATE	1
SPMAK-SCX-A14	14	6-1.0X40MM SOCKET HEAD BOLT	1
SPMAK-SCX-A15	15	BENDING PLATE FOR LOCKING	1
SPMAK-SCX-A16	16	LOCK NUT	1
SPMAK-SCX-A17	17	10-1.5X45 SOCKET HEAD BOLT	1
SPMAK-SCX-A18	18	LOCKING BLOCK	1
SPMAK-SCX-A19	19	MAGNET	2
SPMAK-SCX-A20	20	LOCK NUT	1
SPMAK-SCX-A21	21	LOCKING HANDLE	1
SPMAK-SCX-A22	22	6-1.0 FLAT HEAD SCREW	2
SPMAK-SCX-A23	23	PLASTIC PAD ON FENCE PARALLEL ADJUSTING PLATE	2
SPMAK-SCX-A24	24	FENCE PARALLEL ADJUSTING PLATE	1
SPMAK-SCX-A25	25	SQUARE NUT	2
SPMAK-SCX-A26	26	POINTER	1
SPMAK-SCX-A27	27	POINTER MOUNTING PLATE	1
SPMAK-SCX-A28	28	4-0.7X6 PAN HEAD SCREW	4
SPMAK-SCX-A29	29	6MM FLAT WASHER	2
SPMAK-SCX-A30	30	6-1.0X6 PAN HEAD SCREW	2
SPMAK-SCX-A31	31	6-1.0X6 SET SCREW	2
SPMAK-SCX-A32	32	PLASTIC SET SCREW	2
SPMAK-SCX-A33	33	PUSH STICK	1
SPMAK-SCX-A34	34	LOCK NUT	1
SPMAK-SCX-A35	35	FLAT WASHER	2
SPMAK-SCX-A36	36	RETAINING RING	2
SPMAK-SCX-A37	37	KICKBACK PAWL	2
SPMAK-SCX-A38	38	BUSHING	2
SPMAK-SCX-A39	39	SPRING	1
SPMAK-SCX-A40	40	3-0.5X10 PAN HEAD SCREW	1
SPMAK-SCX-A41	41	SUPPORT BRACKET	1

Part A

PARTS NUMBER	ITEM	PARTS NAME	QTY
SPMAK-SCX-A42	42	4X30MM SPRING PIN	1
SPMAK-SCX-A43	43	PIVOT PIN	1
SPMAK-SCX-A44	44	4X12MM SPRING PIN	1
SPMAK-SCX-A45	45	LATCH	1
SPMAK-SCX-A46	46	6-1.0X60MM HEX HEAD BOLT	1
SPMAK-SCX-A47	47	6MM FLAT WASHER	1
SPMAK-SCX-A48	48	LEFT BLADE GUARD	1
SPMAK-SCX-A49	49	LOCK NUT	1
SPMAK-SCX-A50	50	6MM FLAT WASHER	1
SPMAK-SCX-A51	51	5-0.8X20MM SET SCREW	2
SPMAK-SCX-A52	52	4-0.7X10MM FLAT HEAD SCREW	2
SPMAK-SCX-A53	53	SUPPORT PLATE	1
SPMAK-SCX-A54	54	GUARD CASE	1
SPMAK-SCX-A55	55	BUSHING	2
SPMAK-SCX-A56	56	PLATE	1
SPMAK-SCX-A57	57	PIVOT PIN	1
SPMAK-SCX-A58	58	4X12MM SPRING PIN	1
SPMAK-SCX-A59	59	LATCH	1
SPMAK-SCX-A60	60	RIGHT BLADE GUARD	1
SPMAK-SCX-A61	61	6MM FLAT WASHER	1
SPMAK-SCX-A62	62	LOCK NUT	1
SPMAK-SCX-A63	63	KNOB	1
SPMAK-SCX-A64	64	8MM FLAT WASHER	1
SPMAK-SCX-A65	65	MITER GAUGE	1
SPMAK-SCX-A66	66	4-0.7MM HEX NUT	3
SPMAK-SCX-A67	67	4-0.7X16MM PAN HEAD SCREW	3
SPMAK-SCX-A68	68	4-0.7X10MM PAN HEAD SCREW	1
SPMAK-SCX-A69	69	POINTER	1
SPMAK-SCX-A70	70	BLOCK	1
SPMAK-SCX-A71	71	PIN	1
SPMAK-SCX-A72	72	4-0.7X12MM PAN HEAD SCREW	2
SPMAK-SCX-A73	73	SCREW	1
SPMAK-SCX-A74	74	BAR	1
SPMAK-SCX-A75	75	WASHER	1
SPMAK-SCX-A76	76	6-1.0X8MM FLAT HEAD SCREW	1
SPMAK-SCX-A77	77	4MM FLAT WASHER	1
SPMAK-SCX-A78	78	4-0.7X20MM PAN HEAD SCREW	1
SPMAK-SCX-A79	79	LASER SWITCH	1
SPMAK-SCX-A80	80	LASER AND BOX ASSEMBLLY	1

PARTS NUMBER	ITEM	PARTS NAME	QTY
SPMAK-SCX-A81	81	BATTERY BOX ASSEMBLY	1
SPMAK-SCX-A82	82	BATTERY COVER	1
SPMAK-SCX-A83	83	THREAD FORMING SCREW	2
SPMAK-SCX-A84	84	AAA BATTERY	2

PART B

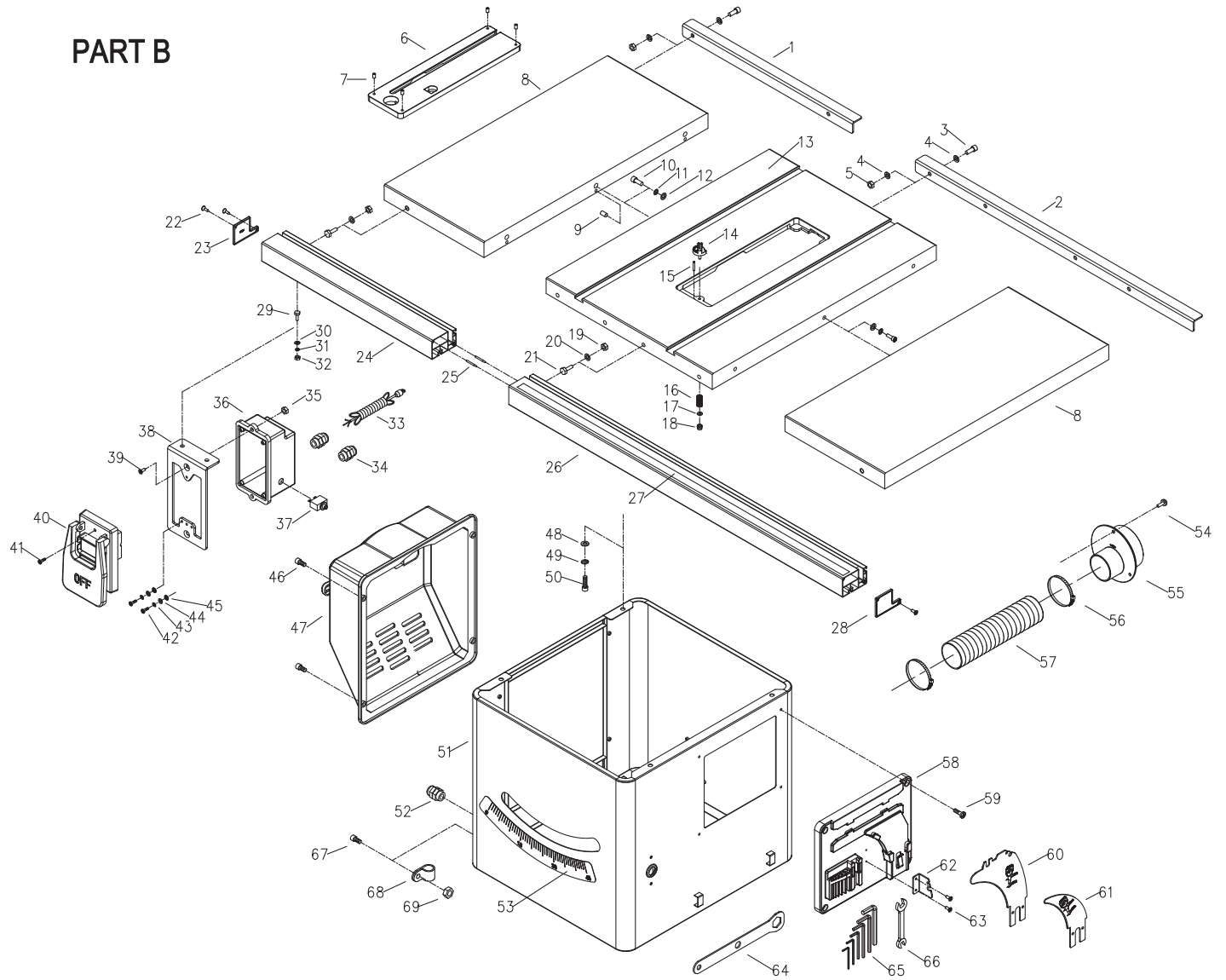

Part B

PARTS NUMBER	ITEM	PARTS NAME	QTY
SPMAK-SCX-B01	1	LEFT REAR RAIL	1
SPMAK-SCX-B02	2	RIGHT REAR RAIL	1
SPMAK-SCX-B03	3	8-1.25X25MM SOCKET HEAD BOLT	6
SPMAK-SCX-B04	4	8MM FLAT WASHER	12
SPMAK-SCX-B05	5	8-1.25MM HEX NUT	6
SPMAK-SCX-B06	6	TABLE INSERT	1
SPMAK-SCX-B07	7	6-1.0X12MM SET SCREW	4
SPMAK-SCX-B08	8	TABLE EXTENSION	2
SPMAK-SCX-B09	9	8-1.25X10MM SET SCREW	6
SPMAK-SCX-B10	10	10-1.5X25MM SOCKET HEAD BOLT	6
SPMAK-SCX-B11	11	10MM LOCK WASHER	6
SPMAK-SCX-B12	12	10MM FLAT WASHER	6
SPMAK-SCX-B13	13	TABLE	1
SPMAK-SCX-B14	14	KNOB FOR LOCKING TABLE INSERT	1
SPMAK-SCX-B15	15	3X10MM SPRING PIN	1
SPMAK-SCX-B16	16	SPRING	1
SPMAK-SCX-B17	17	5MM FLAT WASHER	1
SPMAK-SCX-B18	18	LOCK NUT	1
SPMAK-SCX-B19	19	8-1.25MM HEX NUT	6
SPMAK-SCX-B20	20	8MM FLAT WASHER	6
SPMAK-SCX-B21	21	8-1.25X25MM HEX HEAD BOLT	6
SPMAK-SCX-B22	22	3.5-1.3X9.5MM THREAD FORMING SCREW	4
SPMAK-SCX-B23	23	LEFT FRONT RAIL CAP	1
SPMAK-SCX-B24	24	LEFT FRONT RAIL	1
SPMAK-SCX-B25	25	CONNECTING PIN	2
SPMAK-SCX-B26	26	RIGHT FRONT RAIL	1
SPMAK-SCX-B27	27	SCALE	1
SPMAK-SCX-B28	28	RIGHT FRONT RAIL CAP	1
SPMAK-SCX-B29	29	6-1.0X16MM HEX HEAD BOLT	2
SPMAK-SCX-B30	30	6MM FLAT WASHER	2
SPMAK-SCX-B31	31	6MM LOCK WASHER	2
SPMAK-SCX-B32	32	6-1.0MM HEX NUT	2
SPMAK-SCX-B33	33	POWER CORD	1
SPMAK-SCX-B34	34	STRAIN RELIEF	2
SPMAK-SCX-B35	35	5-0.8MM HEX NUT	2
SPMAK-SCX-B36	36	SWITCH BOX	1
SPMAK-SCX-B37	37	CIRCUIT BREAKER	1

PARTS NUMBER	ITEM	PARTS NAME	QTY
SPMAK-SCX-B38	38	SWITH MOUNTING PLATE	1
SPMAK-SCX-B39	39	5-0.8X10MM FLAT HEAD SCREW	2
SPMAK-SCX-B40	40	SWITCH	1
SPMAK-SCX-B41	41	4-0.7X16MM PAN HEAD SCREW	2
SPMAK-SCX-B42	42	4MM SERRIATED WASHER	2
SPMAK-SCX-B43	43	4MM FLAT WASHER	2
SPMAK-SCX-B44	44	4MM LOCK WASHER	2
SPMAK-SCX-B45	45	4-0.7X8MM PAN HEAD SCREW	2
SPMAK-SCX-B46	46	6-1.0X16MM SOCKET PAN HEAD SCREW	4
SPMAK-SCX-B47	47	LEFT COVER FOR BOX BASE	1
SPMAK-SCX-B48	48	8MM FLAT WASHER	2
SPMAK-SCX-B49	49	8MM LOCK WASHER	2
SPMAK-SCX-B50	50	8-1.25X16MM SOCKET HEAD BOLT	4
SPMAK-SCX-B51	51	BOX BASE	1
SPMAK-SCX-B52	52	STRAIN RELIEF	1
SPMAK-SCX-B53	53	ANGLE SCALE	1
SPMAK-SCX-B54	54	6-1.0X16MM SOCKET PAN HEAD SCREW	3
SPMAK-SCX-B55	55	4" DUST CHUTE	1
SPMAK-SCX-B56	56	HOSE CLAMP	2
SPMAK-SCX-B57	57	HOSE	1
SPMAK-SCX-B58	58	HARDWARE STORAGE	1
SPMAK-SCX-B59	59	6-1.0X20MM SOCKET HEAD BOLT	4
SPMAK-SCX-B60	60	RIVING KNIFE	1
SPMAK-SCX-B61	61	RIVING KNIFE (SMALL)	1
SPMAK-SCX-B62	62	PAWL STORAGE	1
SPMAK-SCX-B63	63	3.5-1.3X9.5MM THREAD FORMING SCREW	2
SPMAK-SCX-B64	64	24MM WRENCH	1
SPMAK-SCX-B65	65	HEX WRENCH	1
SPMAK-SCX-B66	66	10-13MM WRENCH	1
SPMAK-SCX-B67	67	5-0.8X16MM SOCKET HEAD SCREW	1
SPMAK-SCX-B68	68	CORD CLAMP	1
SPMAK-SCX-B69	69	5-0.8MM HEX NUT	1

PART C

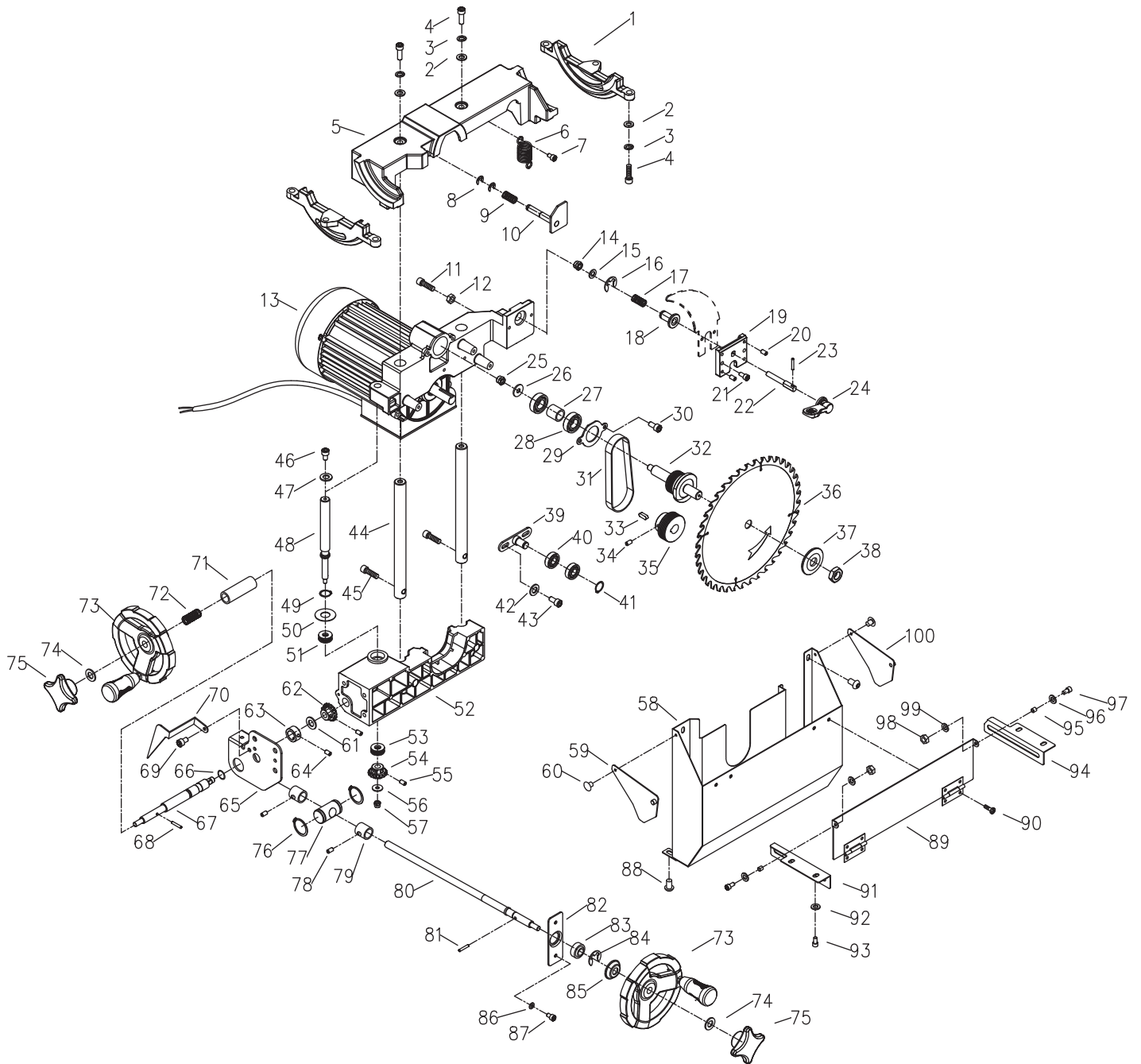

Part C

PARTS NUMBER	ITEM	PARTS NAME	QTY
SPMAK-SCX-C01	1	TRUNNION	2
SPMAK-SCX-C02	2	8MM FLAT WASHER	8
SPMAK-SCX-C03	3	8MM LOCK WASHER	8
SPMAK-SCX-C04	4	8-1.25X25MM SOCKET HEAD BOLT	8
SPMAK-SCX-C05	5	BEVEL BASE	1
SPMAK-SCX-C06	6	SPRING	1
SPMAK-SCX-C07	7	8-1.25X12MM SOCKET HEAD BOLT	1
SPMAK-SCX-C08	8	RETAINING RING	2
SPMAK-SCX-C09	9	SPRING	1
SPMAK-SCX-C10	10	LOCKING PLATE	1
SPMAK-SCX-C11	11	8-1.25X25MM SOCKET HEAD BOLT	1
SPMAK-SCX-C12	12	8-1.25MM HEX NUT	1
SPMAK-SCX-C13	13	MOTOR	1
SPMAK-SCX-C14	14	LOCK NUT	1
SPMAK-SCX-C15	15	8MM FLAT WASHER	1
SPMAK-SCX-C16	16	RETAINING RING	1
SPMAK-SCX-C17	17	SPRING	1
SPMAK-SCX-C18	18	LOCK BUSHING	1
SPMAK-SCX-C19	19	RIVING KNIFE OUTER SUPPORT BLOCK	1
SPMAK-SCX-C20	20	6-1.0X10MM SET SCREW	4
SPMAK-SCX-C21	21	6-1.0X20MM SOCKET PAN HEAD SCREW	2
SPMAK-SCX-C22	22	LOCK SHAFT	1
SPMAK-SCX-C23	23	PIN	1
SPMAK-SCX-C24	24	RIVING KNIFE LOCKING HANDLE	1
SPMAK-SCX-C25	25	LOCK NUT	1
SPMAK-SCX-C26	26	10MM FLAT WASHER	4
SPMAK-SCX-C27	27	BUSHING	1
SPMAK-SCX-C28	28	6003ZZ BALL BEARING	2
SPMAK-SCX-C29	29	BEARING COVER PLATE	1
SPMAK-SCX-C30	30	6-1.0X12MM SOCKET HEAD BOLT	2
SPMAK-SCX-C31	31	V BELT	1
SPMAK-SCX-C32	32	SPINDLE	1
SPMAK-SCX-C33	33	5X5X30MM KEY	1
SPMAK-SCX-C34	34	6-1.0X8MM SET SCREW	1
SPMAK-SCX-C35	35	MOTOR PULLEY	1
SPMAK-SCX-C36	36	BLADE	1
SPMAK-SCX-C37	37	BLADE CLAMP	1
SPMAK-SCX-C38	38	NUT	1
SPMAK-SCX-C39	39	BELT TENSION BREAKET	1
SPMAK-SCX-C40	40	6001ZZ BALL BEARING	2
SPMAK-SCX-C41	41	RETAINING RING	1

Part C

PARTS NUMBER	ITEM	PARTS NAME	QTY
SPMAK-SCX-C42	42	6MM FLAT WASHER	4
SPMAK-SCX-C43	43	6-1.0X12MM SOCKET HEAD BOLT	2
SPMAK-SCX-C44	44	GUIDE ROD	2
SPMAK-SCX-C45	45	8-1.25X30MM SOCKET HEAD BOLT	2
SPMAK-SCX-C46	46	6MM FLAT WASHER	1
SPMAK-SCX-C47	47	6-1.0X10MM SOCKET HEAD BOLT	1
SPMAK-SCX-C48	48	SCREW	1
SPMAK-SCX-C49	49	RETAINING RING	1
SPMAK-SCX-C50	50	WASHER	1
SPMAK-SCX-C51	51	51100 THRUST BALL BEARING	1
SPMAK-SCX-C52	52	LOWER CASE	1
SPMAK-SCX-C53	53	6000 BALL BEARING	1
SPMAK-SCX-C54	54	BEVEL GEAR	1
SPMAK-SCX-C55	55	6-1.0X8MM SET SCREW	2
SPMAK-SCX-C56	56	6MM FLAT WASHER	1
SPMAK-SCX-C57	57	LOCK NUT	1
SPMAK-SCX-C58	58	BLADE COVER WITH 2.5" DUST CHUTE	1
SPMAK-SCX-C59	59	FRONT BAFFLE	1
SPMAK-SCX-C60	60	4X5MM RIVET	2
SPMAK-SCX-C61	61	10MM FLAT WASHER	1
SPMAK-SCX-C62	62	BEVEL GEAR	1
SPMAK-SCX-C63	63	LIMITTING BUSHING	1
SPMAK-SCX-C64	64	6-1.0X8MM SET SCREW	4
SPMAK-SCX-C65	65	SUPPORT BRACKET	1
SPMAK-SCX-C66	66	O RING	1
SPMAK-SCX-C67	67	HANDWHEEL SHAFT	1
SPMAK-SCX-C68	68	3X20MM SPRING PIN	1
SPMAK-SCX-C69	69	6-1.0X10MM SOCKET HEAD BOLT	1
SPMAK-SCX-C70	70	ANGLE POINTER	1
SPMAK-SCX-C71	71	BUSHING	1
SPMAK-SCX-C72	72	SPRING	1
SPMAK-SCX-C73	73	HANDWHEEL	2
SPMAK-SCX-C74	74	8MM FLAT WASHER	2
SPMAK-SCX-C75	75	LOCK NUT	2
SPMAK-SCX-C76	76	RETAINING RING	2
SPMAK-SCX-C77	77	NUT	1
SPMAK-SCX-C78	78	8-125X8MM SET SCREW	2
SPMAK-SCX-C79	79	LIMITTING BUSHING	2
SPMAK-SCX-C80	80	ANGLE ADJUSTING SCREW	1

PARTS NUMBER	ITEM	PARTS NAME	QTY
SPMAK-SCX-C81	81	3X20MM SPRING PIN	1
SPMAK-SCX-C82	82	BEARING FIXING PLATE	1
SPMAK-SCX-C83	83	BEARING	1
SPMAK-SCX-C84	84	RETAINING RING	1
SPMAK-SCX-C85	85	BEVEL LOCKING PALTE	1
SPMAK-SCX-C86	86	5MM FLAT WASHER	2
SPMAK-SCX-C87	87	5-0.8X12MM SOCKET HEAD SCREW	2
SPMAK-SCX-C88	88	6-1.0X10MM SOCKET PAN HEAD SCREW	4
SPMAK-SCX-C89	89	Bevel cover	1
SPMAK-SCX-C90	90	4-0.7X8mm Pan head screw	4
SPMAK-SCX-C91	91	Front support plate	1
SPMAK-SCX-C92	92	6mm Flat washer	4
SPMAK-SCX-C93	93	6-1.0x10mm Socket pan head screw	4
SPMAK-SCX-C94	94	Rear support plate	1
SPMAK-SCX-C95	95	Bushing	2
SPMAK-SCX-C96	96	5mm Flat washer	2
SPMAK-SCX-C97	97	5-0.8x14mm Socket head screw	2
SPMAK-SCX-C98	98	5mm Flat washer	2
SPMAK-SCX-C99	99	5-0.8mm Hex nut	2
SPMAK-SCX-C100	100	Rear baffle	1

PART D

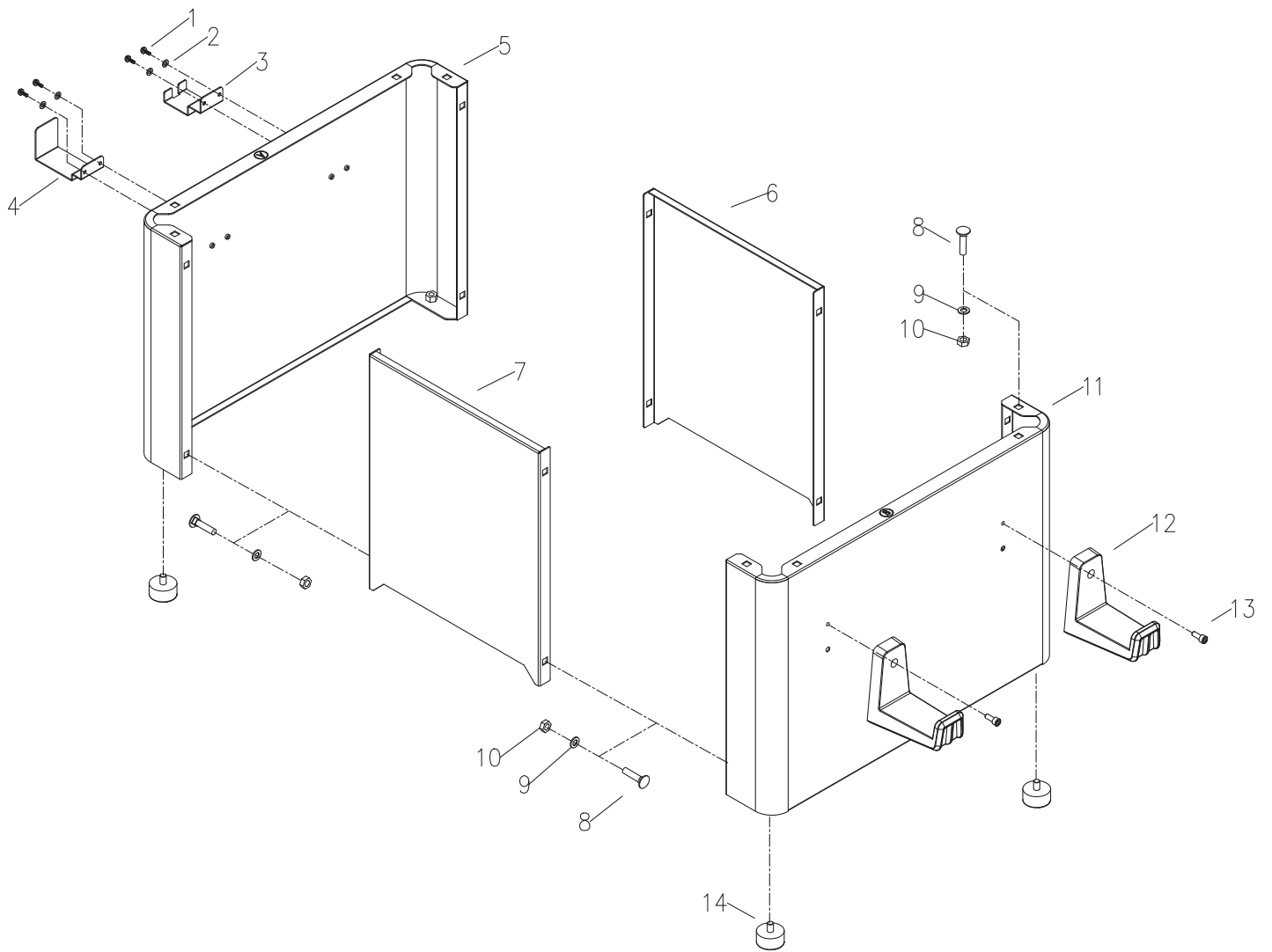

Part D

PARTS NUMBER	ITEM	PARTS NAME	QTY
SPMAK-SCX-D01	1	4-0.7X8MM PAN HEAD SCREW	4
SPMAK-SCX-D02	2	4MM FLAT WASHER	4
SPMAK-SCX-D03	3	REAR BLADE GUARD BRACKET	1
SPMAK-SCX-D04	4	FRONT BLADE GUARD BRACKET	1
SPMAK-SCX-D05	5	LEFT PANEL	1
SPMAK-SCX-D06	6	CONNECTING PANEL	1
SPMAK-SCX-D07	7	CONNECTING PANEL	1
SPMAK-SCX-D08	8	8-1.25X16MM CARRIAGE BOLT	16
SPMAK-SCX-D09	9	FLAT WASHER	16
SPMAK-SCX-D10	10	8-1.25MM HEX NUT	16
SPMAK-SCX-D11	11	RIGHT PANEL	1
SPMAK-SCX-D12	12	FENCE STORAGE	2
SPMAK-SCX-D13	13	6-1.0X20MM SOCKET HEAD BOLT	2
SPMAK-SCX-D14	14	FOOT	4

9 Wiring Diagram

WIRING DIAGRAM
3-Wire 220V 1Phase

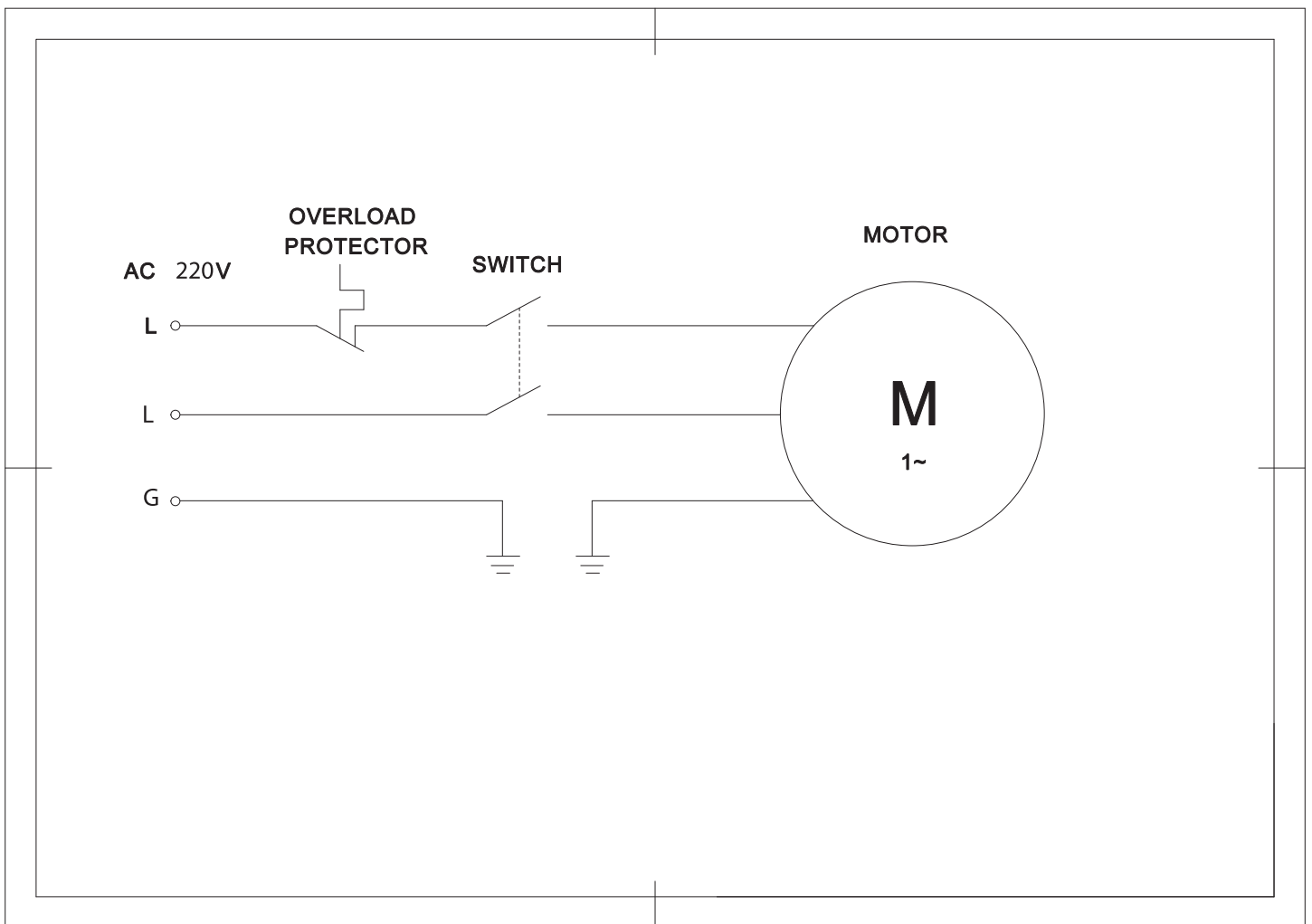

10 Terms of Warranty

MAKSIWA assures the owner that their equipment, identified by the Serial number issued on the Warranty Terms.

The equipment under warranty, for two (2) years, is as followed:

1. The warranty period begins on the date of the Warranty Terms below.
2. Within the warranty period, the manual labor and the components replaced by manufacturing defect will be provided for free if duly proved by Maksiwa Service.
3. Third-party manufacturing equipment that makes up the MAKSIWA equipment (such as motors, electrical equipment, belts etc.) are subject to the terms and conditions of warranty of their respective manufacturers.
4. In case an exchange of machine is needed, please return the defective part or machine to MAKSIWA.
5. All workplace adaptations for the equipment are under the responsibility of the machine owner.
6. If you notice any defect or malfunction when receiving the equipment, get in touch immediately with the manufacturer or Dealer. Do not turn it on.
7. Not included in this warranty is any technical visits aimed at cleaning or adjustments caused by wear, resulting from normal use of the equipment.
8. The warranty does not cover problems caused by mistreatment, carelessness, misuse or inappropriate use of the functions designed for this equipment in this manual, as well as poorly executed operations by untrained operators to operate it.
9. MAKSIWA is not responsible for lost productivity, direct or indirect damages caused to the owner of the equipment or to third parties, or any other expense, including lost profits.
10. Even under warranty, you may lose its validity as follows:
 - a) Application of non-original components;
 - b) Alteration of its original features;
 - c) Lack of proper maintenance;
 - d) Improper use of the equipment;
 - e) Change in equipment or electronic connections;
 - f) Damage caused by mechanical shock or exposure to unsuitable conditions (humidity, salt spray, corrosive agents, etc.);
 - g) Damage caused by bad weather (floods, flooding, lightning, power outages etc.);
 - h) Maksiwa is not responsible for damages to electrical components cause by power variation in your area.

For your safety, trust the repairs, maintenance and adjustments (including inspection and replacement) for technical assistance recommended by MAKSIWA, always use genuine spare parts and accessories, reassembling to its original machine the same way.

MODEL:

SERIAL NUMBER:

DATE:

LOT NUMBER:

Imported by:

Maksiwa International Inc.

4100 N Powerline Rd, Suite D3

Pompano Beach, Florida

ZIP Code: 33073

Telephone: +1 (754) 205-6717 | Call us free: +1 (844) 319-6594

E-mail: tech@maksiwa.com

www.maksiwa.com