



# MAKSIWA®

## CP/1.C

**Dust Collector**

INSTRUCTION MANUAL



Caution: Read this manual before to use the machine.

# Instruction Manual

## TABEL OF CONTENTS

1. Unpacking and checking contents
2. Assembly
3. Parts diagram
4. Parts list

## CENTRAL SAFETY RULES

Safety is a combination of common sense, staying alert and knowing how your dust collector works.

**WARNING: To avoid mistakes that could cause serious injury, do not plug the dust collector in until the following steps have been read and understood.**

1. READ and become familiar with this entire instruction manual. Learn the machine's application, limitations and possible hazards.
2. AVOID DANGEROUS AONDITIONS. DO NOT use machine in wet or damp areas or expose them to rain. Keep work area well lit.
3. DO NOT use machine in the presence of flammable liquids or garses.
4. KEEP BYSTANDERS AT A SAFE DISTANCE FROM the work area, especially when machine is operating. NEVER allow children near the machine.
5. DO NOT FORCE THE MACHINE to do a job for which it was not designed.
6. DRESS FOR SAFETY. DO NOT wear loose clothing, gloves, neckties, or jewelry(rings, watches) when operating tool. They can get caught and draw you into moving parts. ALWAYS wear non-slip footwear, and tie back long hair.
7. WEAR A FACE MASK OR DUST MASK.
8. ALWAYS remove the power cord plug from the electrical outlet when making adjustments, changing parts cleaning machine.
9. AVOID ACIDENTAL START-UPS. Make sure that the power switch is in the "OFF" position before plugging in the power cord.
10. NEVER LEAVE A MACHINE RUNNING UNATTACHED. Turn the power switch to "OFF". DO NO T leave tool until it has come to a complete stop.
11. NEVER STAND ON A MACHIEN. Serious injury could result if the machine tips or is accidentally hit.
12. DON'T OVERREACH. Keep proper footing and balance at all times. Wear oil-resistant rubber-soled footwear. Keep floor clear of oil, scrap and other debris.
13. MAINTIAN MACHINE PROPERLY. ALWAYS keep

machine clean and in good working order. Follow instructions for lubricating and changing accessories.

14. CHECKDAMAGED PARTS. Check for alignment of moving parts, binding of moving parts, breakage of parts, improper mounting or any other conditions that may affect the machine's operation. Any part that is damaged should be properly repaired or replaced before use.

15. WARNING: Dust generated from certain materials can be hazardous to your health.

ALWAYS WEAR EYE PROTECTION. A dust collector can throw foreign objects in to the eyes, which could cause permanent eye damage.

ALWAYS wear safety goggles (not glasses). Ordinary glasses have only impact-resistant lenses...thy ARE NOT safety goggles.

## SPECIFIC SAFETY RULES FOR DUST COLLECTION

When using your Dust Collection System, follow basic safety precautions including the following:

**TO REDUCE THRE RISK OF FIRE, ELECTRIC SHOCK, OR INJURY. READ AND UNDERSTAND THIS INSTRUCTION MANUAL AND ALL LABELS ON THE DUST COLLECTOR BEFORE OERATING. USE ONLY AS DESCRIBED IN THIS MANUAL.**

1. THE FILTRATION HOUSING contains a high speed fan blade that can amputate fingers, grab loose clothing and neckties, and propel dust at high velocities. DO NOT OPERATE WITHOUT AL APRTS IN PLACE.
2. DO NOT attempt to clean, remove the dust bags, or service the unit when the power is ON. Turn the unit "OFF" and disconnect the cord from the power source.
3. STATIC SHOCKS ARE common in dry areas or when the relative humidity of the air is low. The use of a humidifier in the home will help raise the relative humidity, and may reduce static shocks.
4. SPARKS inside the electrical parts can ignite flammable vapors or dust.
5. DO NOT vacuum, or use the Dust Collector near flammable or combustible liquids, gases, gasoline or other fuels, lighter fluid, cleaners, oil-based paints, natural gas, hydrogen, or explosive dusts like coal dust, magnesium dust, grain dust, or gun powder.
6. TO AVOID HEALTH HAZARDS from vapors or dusts, do not vacuum toxic materials.
7. TO AVOID HTALTH HAZARDS from vapors or dusts, don't vacuum toxic materials.
8. DO NOT use or store near hazardous material.
9. DO NOT use outdoors or on wet surfaces.

10. PUT THE UNIT on a stable, level surface.
11. POSITION the vacuum hose and electric cord away from traffic areas.
12. DO NOT ALLOW THE UNIT TO BE USED AS A TOY. Close attention is necessary when used by or near children.
13. DO NOT LEAVE the Dust Collector plugged in. Unplug from the outlet when not in use and before servicing.
14. TO AVOID INJURY from accidental starting, unplug the power cord before changing or cleaning the filter/dust bag or chip bag.
15. DO NOT use without the filter /dust bag and /or chip bag in place.
16. DO NOT unplug by pulling on the cord. To unplug, grasp the plug, not the cord.
17. TURN OFF THE CONTROLS before unplugging.
18. DO NOT use with a damaged cord, plug, or other parts. If your Dust Collection System is not working as it should, has missing parts, has been dropped, damaged, left outdoors, or dropped into water, return it to an authorized Service Center.
19. DO NOT pull or carry by cord, use the cord as a handle, close the door on the cord, or pull the cord. Keep the cord away from heated surfaces.
20. DO NOT handle the plug of the Dust Collector with wet hands.
21. DO NOT put any object near the ventilation openings. Do not vacuum with any ventilation opening blocked; keep free of dust, lint, hair or anything that may reduce air flow.
22. KEEP hair, loose clothing, fingers, and all parts of the body away from opening and moving parts.
23. EXTENSION CORDS in poor condition or that are too small can cause fire and shock hazards. When using an extension cord, be sure it is in good condition.
24. CONNECT to a properly grounded outlet only.
25. USE ONLY heavy duty plastic trash bags when replacing the chip bag.
26. CAUTION: If using this Dust Collector to help keep airborne wood dust in heavy usage within acceptable limits, you must regularly monitor air borne dust and maintain your Dust Collector to avoid exceeding dust limits. Each application is unique. Your maintenance schedule must, therefore, be tailored to your specific use of this Dust Collector.
27. SAFETY is a combination of common sense, staying alert, and knowing how your Dust Collector works.

**TO AVOID MISTAKES THAT COULD RESULT IN SERIOUS, PERMANENT INJURY, DO NOT CONNECT THE POWER CORD UNTIL THE FOLLOWING STEPS HAVE BEEN SATISFACTORILY COMPLETED.**

28. BEFORE USING THE DUST COLLECTOR SYSTEM:
  - A. Complete the assembly, mounting, and alignment.
  - B. Learn the function and proper use of the ON/OFF

switch.

C. Read and understand all safety instruction and operating procedures throughout the manual.

D. Read the labels that appear on the dust collector.

29. BEFORE EACH USE:

A. Inspect your Dust Collector. If any parts are missing, bent, or fail in any way, or any electrical components do not work properly, turn off the Dust Collector, remove the switch key, and remove the power supply cord from the power supply.

Replace damaged, missing, or failed parts before using the Dust Collector again.

B. Plan your work to protect your eyes, hands, face, ears, and body.

30. WHEN CLEANING collection bags, wear a dust mask.

## UNPACKING AND CHECKING CONTENTS

### PARTS:

- Base: 1 qty
- Electric power collector: 1 qty
- Filtration housing: 1 qty
- Bags: 2 qty
- Packing: 1 qty
- Fixing parts: 1 bag
- Caster - Directional Caster: 2
- Caster - Universal Caster: 2
- Support rod: 4
- Block: 4
- Handle: 1
- Vertical stand: 1

## ASSEMBLY

Stand the base and adjust the caster holes to align with the base holes, then tighten the nuts and screws by means of screwdriver and wrench.

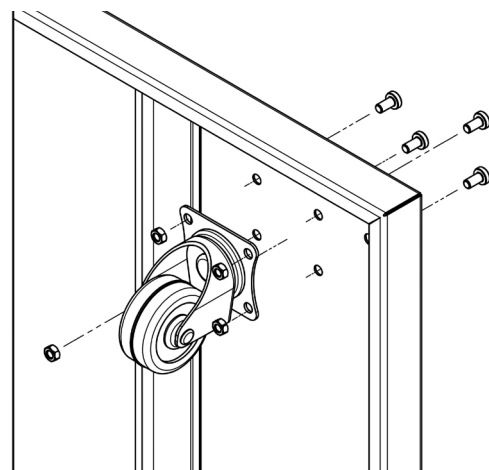

Fig. 01

Align the filtration housing inlet with the electric power collector outlet, insert the packing between them, then tighten them together with six bolts.

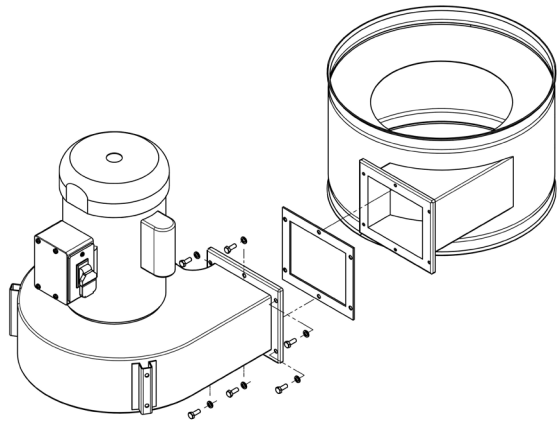

Fig. 02

Mount two support rods and proper block on the electric power collector by bolt.

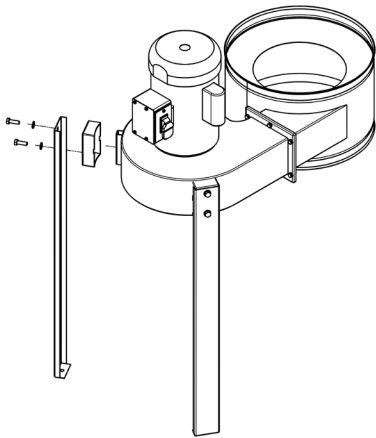

Fig. 03

Mount another two support rods with block and handle on the filtration housing by bolt.

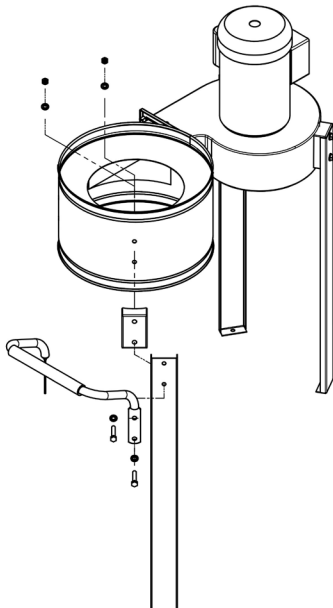

Fig. 04

Put the base down and place the assembled collector and filtration housing on it, and align the holes on the bottom end of the four support rods with those on the base, then insert the bolts and tighten.

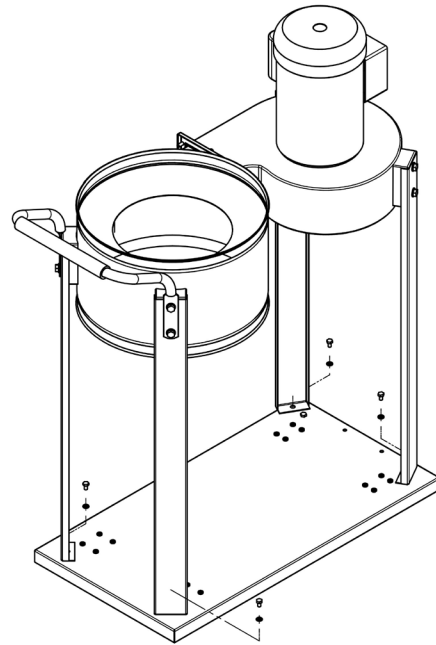

Fig. 05

Put the hook of the vertical stand upwards, align the two holes with those on the filtration housing, insert the screw and tighten.

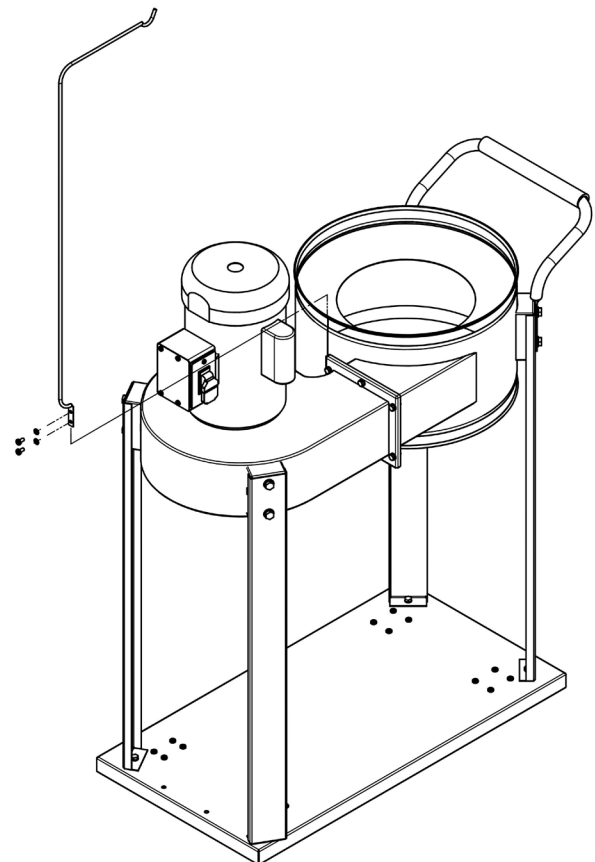
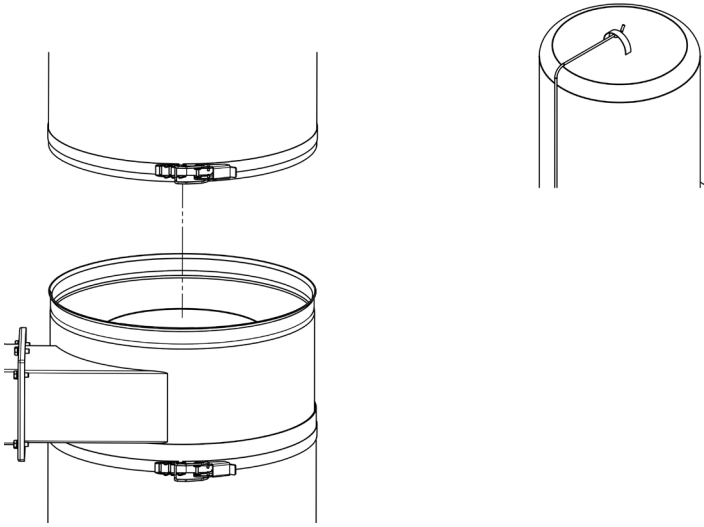

Fig. 06

Attach the bottom end of the bag with the holder on the filtration housing, hold the holder on the hook, then fasten the strap. Attach the lower bag on the bottom end of the filtration housing and fasten the strap.



*Fig. 07*

Then the machine has been finished assembly. A re-inspection is necessary to do to check whether the bolts and screws are loosing. After the re-inspection, you can connect the machine to a power source and have a trial run.

NOTE: The trial run should be done according to the Safety Rules.

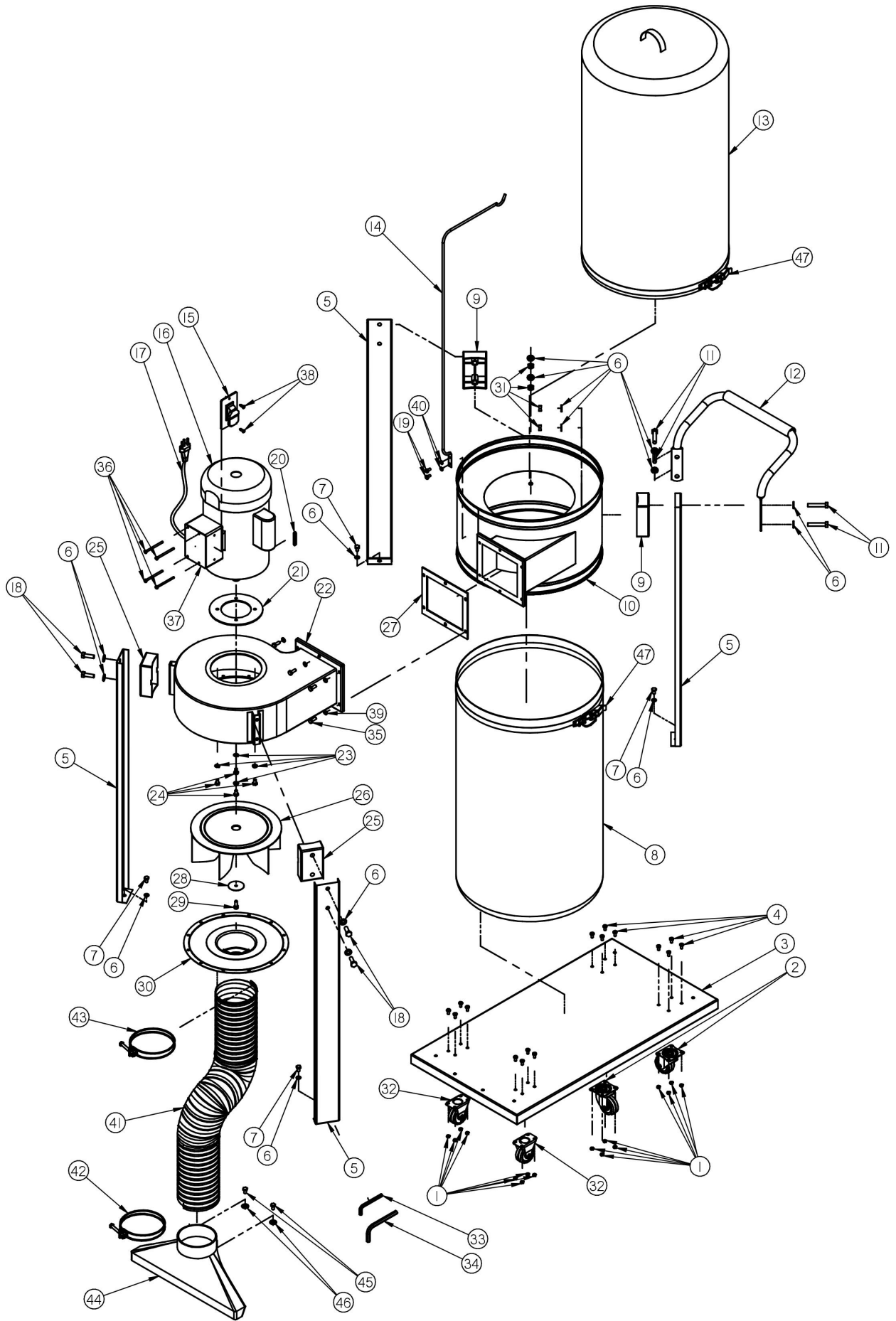

**Part List:**

<b>Nº</b>	<b>Description</b>	<b>Nº</b>	<b>Description</b>
1	Screw pan HD	25	Block
2	Universal back caster	26	Turbo fan
3	Base	27	Packing
4	Nut	28	Washer
5	Support rod	29	Screw hex stocket
6	Washer	30	Inlet
7	Screw hex HD	31	Nut
8	Collector bag	32	Directional caster
9	Collector block	33	Wrench hex
10	Filtration housing	34	Wrench hex
11	Screw hex HD	35	Screw hex
12	Handle	36	Screw pan HD
13	Filter bag	37	Switch cover
14	Vertical stand	38	Cross slot screw
15	Switch	39	Washer
16	Motor	40	Washer
17	Power cord	41	Hose
18	Screw hex HD	42	Hose clamp
19	Screw pan HD	43	Hose clamp
20	Key	44	Floor sweeper
21	Packing	45	Bolt
22	Fan housing	46	Washer
23	Spring washer	47	Bag clamp
24	Screw hex HD		

**How to use the floor sweeper:**

This item has a separate useful sweeper what can collect saw dust and wood chips on the floor. And also this item can be directly fitted to other wood machines and collect saw dust and wood chips resulted from Woodworking operations.

Follow these instructions to fit the floor sweeper:

1. Insert hose clamp (part 43) on the end of 4" hose and then assembly to the inlet of fan housing.
2. Insert hose clamp (part 42) on the other end of floor sweeper (part 44).

**Warning! BE SURE UN-CONNECT THE POWER FROM THE MACHINE BEFORE ASSEMBLING THE MACHINE.**