



MAKSIWA®

BMP.3200.IR

Sliding Panel Saw Platinum

INSTRUCTION MANUAL



Attention: Read this manual before using the machine.

Greetings,

Congratulations, you just purchased the BMP.3200.IR Platinum Sliding Panel Saw, which was developed with Maksiwa's highest standards of technology and quality. Your new Platinum Sliding Panel Saw will allow you increase your productivity on your shop. Besides a great finish, the BMP.3200.IR ensures that your cuts are always precise. It should be noted that to use this machine with maximum efficiency, you should read and understand the instructions in this manual. Visit our website to know about our launches and other products:

www.maksiwa.com

Index

| | | |
|--------|--|----|
| 1 | Safety Regulations..... | 05 |
| 1.1 | Workspace..... | 05 |
| 1.2 | Electrical Safety..... | 05 |
| 1.3 | Personal Safety..... | 06 |
| 1.4 | Machine Safety..... | 06 |
| 2 | Description..... | 09 |
| 2.1 | Specifications..... | 09 |
| 2.2 | Components..... | 11 |
| 2.2.1 | Mobile Arm..... | 12 |
| 2.2.2 | Mobile Table Guide..... | 12 |
| 2.2.3 | Blade Tilt Control Handle..... | 13 |
| 2.2.4 | Control Panel..... | 14 |
| 2.2.5 | Emergency Buttons/Switches..... | 15 |
| 2.2.6 | Main Table Lock..... | 16 |
| 2.2.7 | Sliding Table Handle..... | 16 |
| 2.2.8 | Adjustable Table Handle..... | 17 |
| 2.2.9 | Rear Extension Table..... | 17 |
| 2.2.10 | Rip Fence..... | 18 |
| 2.2.11 | Panel Pushing Handle..... | 19 |
| 2.2.12 | Blade Protector Cover..... | 19 |
| 2.2.13 | Dust Collection Port..... | 20 |
| 2.2.14 | Support Table..... | 21 |
| 2.2.15 | Wood Panel Clamp..... | 21 |
| 2.2.16 | Aluminum Table Guide..... | 22 |
| 2.2.17 | Scoring Blade Adjustment Location..... | 23 |
| 2.2.18 | Wood Panel Stopper..... | 24 |
| 2.2.19 | Main Blade Height Adjustment Handle..... | 25 |
| 2.2.20 | Aluminum Guide Extensions..... | 25 |
| 2.2.21 | Digital Readout..... | 26 |
| 3 | Installation..... | 50 |
| 3.1 | Electrical Installation..... | 50 |
| 3.2 | Assembly..... | 50 |
| 4 | Operation..... | 66 |
| 4.1 | Main Blade Adjustments..... | 67 |
| 4.2 | Scoring Blade Adjustments..... | 68 |
| 4.3 | How to Cut at Different Angles..... | 69 |
| 4.4 | How to Setup for Recurrent Cuts..... | 70 |

| | |
|--|-----|
| 4.5 Running a Piece..... | 71 |
| 4.6 Cross Cutting..... | 72 |
| 4.7 Cutting Frames, Boxes and Other Four-Sided Pieces..... | 72 |
| 4.8 Bevel Cuts..... | 73 |
| 4.9 Support for Long Parts..... | 73 |
| 4.10 How to Adjust the Rip Fence..... | 73 |
| 4.11 Main Blade..... | 74 |
| 4.12 Fence Scale Alignment..... | 75 |
| 4.13 Riving Knife Adjustment..... | 75 |
| 4.14 Changing Scoring Blade..... | 76 |
| 4.15 Rip Cutting..... | 76 |
| 4.16 Lubrication..... | 77 |
| 4.17 Replace Belts..... | 78 |
| 5 Maintenance..... | 79 |
| 5.1 General Cleanliness..... | 79 |
| 5.2 Electrical Maintenance..... | 79 |
| 5.3 Mechanical Maintenance..... | 79 |
| 5.4 Saw Blade Lubrication Chart..... | 80 |
| 5.5 Part Replacement and Disposal..... | 80 |
| 6 Troubleshooting Guide..... | 81 |
| 7 Exploded View..... | 82 |
| 8 Terms of Warranty..... | 125 |

1 Safety Regulations

Read all instructions in this manual. Failure to follow all instructions listed below may result in personal injury and equipment damage. **WARNING:** When using electrical equipment, always follow the safety precautions to reduce risk of fire, electric shock and personal injury. The manufacturer declares that they are not liable for damages to person(s) or object(s) which may be caused by failure to comply with the safety regulations.

1.1 Workspace

- Keep the work surface clean. Disorganized surfaces and areas are an invitation, for accidents in the work place.
- Do not use the saw in hazardous environments. Do not use the machine in places that are damp, wet, exposed to rain, or in the presence of flammable liquids or gases. Keep your work area well lit.
- Visitors must be kept at a safe distance from the workspace. Take the appropriate precaution by using padlocks or following the appropriate lock-out-tag procedures.

1.2 Electrical Safety

- Ensure that your power supply is in accordance with the rating of the machine. A 10% increase or decrease in voltage will cause power loss and overheating. All Maksiwa equipment is factory tested. If this Machine does not operate properly, first check the power supply.
- The BMP.3200.IR is constructed with two separate layers of electrical insulation. You do not have to ground the machine if the power supply comes built with an ground.
- **NOTE:** Double insulation is not a substitute for normal safety precautions when operating this machine. The insulation system is to add protection against personal accidents resulting from a possible failure of the machines electrical insulation.
- **CAUTION:** WHEN SERVICING OR REPAIRING THE MACHINE, ONLY USE OEM PARTS.
- The plug used for the machine must be rated for the correct voltage/Amps and compatible with the electrical outlet. Never modify the plug.
- Do not use any adapter plugs. Using the correct plug (without modifications) with the correct outlet will reduce the risk of electrical shock.

1.3 Personal Safety

- Stay alert, pay attention at what you are doing and use common sense when operating the machine. Do not use the machine when you are tired or under the influence of drugs, alcohol, or medication. If distracted, while operating the machine, it may in result in serious personal injury.



ALWAYS USE PROPER PROTECTION WHEN OPERATING THIS EQUIPMENT.

- Always wear safety glasses, face protection, safety anti-slip shoes, and ear protection to reduce personal injury.
- Do not wear loose clothing, gloves, chains, rings, bracelets or other accessories. It is also recommended to use hair protection.
- Do not over stretch to reach. Keep balanced and feet firmly planted at all times.
- Disconnect the machine from the power supply before servicing or performing repairs.
- Reduce the risk of unintended starts by making sure that the main power switch is turned off before plugging the cord into the outlet.
- Use recommended accessories. Refer to the instruction manual to check the recommended accessories. Improper use of the accessories may cause personal injury.
- Never stand on the machine. serious accidents can occur if the machine is tilted or if the blade is accidentally touched.

1.4 Machine Safety

- Turn off the saw, unplug the power cord, and wait until the blade stops, before performing any maintenance or adjustments to the machine.
- Make sure the blades are not worn, as for this will prevent the machine from cutting properly and overload the motors. Do not overload the Machine, it will perform the job better and safer if used as indicated. Do not force the machine by performing a job for which it was not intended for.
- Firmly secure your workpiece. Use clamps if necessary when you cannot secure the workpiece on to the table and against the guide by hand, or when your hand is dangerously close to the blade.
- Inspect the machine. Keep the blades sharp and clean for optimal performance. Follow the instructions on lubricating and changing accessories. Check the alignment of moving parts and for any damaged parts, before continuing to use the machine. A part that is damaged should be carefully examined to determine, if it is functioning properly and if it will affect the machines

performance. A blade cover or any other part that is damaged must be repaired or replaced immediately. Do not use the machine if any the switches do not work properly.

- Never leave the machine running unattended. Turn off the main power switch when not in use to prevent any accidents.
- Protect the power supply circuit with at least a fuse or circuit breaker. Do not attempt to operate the saw at any voltage other than the designated voltage.
- Make sure all blade washers and fasteners are clean. Tighten the shaft nut securely. Keep the saw blades sharp, make sure that the blades are facing the correct directions (main blade spins clockwise) (Scoring blade spins counter-clockwise). See fig 13-4 on pg. 39.
- Keep motor vents free of splinters or saw dust.
- Always use the blade guard cover.
- Keep your hands out of the way of the blades.
- Support long pieces with a wood fastening device.
- Do not use blades larger or smaller than recommended.
- Be careful not bend or damage the cooling fan on the rear of the motors.
- Do not force a cut, partial or complete, motor will shut down and can cause serious damage. Allow the motor to reach its top speed before starting the cut.
- Do not cut ferrous metals (those containing iron or steel in their composition) or any other masonry material.
- Do not use abrasives. Excessive heat generated by abrasive particles will damage the saw blades.
- Do not use blades designated for less than recommend amount.
- Do not cut small pieces without the aid of a fastener. Keep hands away from blades.
- Do not perform any hands-free operation.
- Do not reach around or behind the blades.
- Do not put your hands within 6 inches of the saw blades.
- Do not place your hands under the saw unless it is off and unplugged. The saw blades are exposed in the lower portion of the saw.
- Do not move the workpiece or lift the cover until the blade has stopped.
- Do not use the saw without the support base or if the support base is not properly secured.
- Do not use lubricants or cleaning products (particularly sprays and aerosols) in the vicinity of the plastic protector. The polycarbonate material used on the cover is sensitive to certain products chemicals.
- To Avoid KICKBACK (“Kickback” - the natural tendency of the workpiece to be thrown back towards the operator) keep the blade sharp, free of rust and dry resin; keep the cutting guide parallel to the saw blade; use the saw guards for all work where possible; push the workpiece completely through the saw blade before releasing it; Do not make longitudinal cuts on a workpiece that is twisted, deformed, or that does not have a straight end that serves as a guide; use an anti-kickback device when possible; never cut workpieces that cannot be fixed; Use the

guide when making a cross-section cut; and never cut a large workpiece with loose knots or other defects.

- **ATTENTION:** Any powder created by sanding, cutting, grinding, drilling, and other activities contains chemicals that can cause cancer, birth and other reproductive harm. Some examples of these products are: in lead; crystal silica brick, cement and other masonry products; and arsenic and chromium from chemically treated wood.
- **CAUTION:** Do not connect the machine to the power outlet until this manual is read and understood.
- Always tighten the adjusting tabs before using the saw. Keep hands 15 cm (6 in) away from the saw blade. Never perform operations hands-free and never cross your arms in front of the saw blade. Think, “ How can I avoid accidents?”.
- Do not operate the saw without the guards being in place. Never put your hands on the saw blade. Always wear safety goggles. Turn off the power and wait for the blade to stops before starting to service or making adjustments.

2 Description

The BMP.3200.IR Platinum Sliding Panel Saw was designed to provide excellent finishing cuts of MDF sheets. It can make cuts 0° to 45°, the angle adjustment is simple to read with the built in digital display. Reinforced structure the BMP.3200.IR Platinum supports panels with a thickness of 25 mm (1 in). It has two independent motors, where the main saw motor has 7.5 HP and scoring motor with 3/4HP for long periods of heavy work. With precision aluminum guides, the BMP.3200.IR Platinum is the right choice for anyone looking for quality and accuracy in their cuts.

2.1 Specifications

General:

- Sliding table dimension: 126" x 15 ½" - 3200 x 360 mm
- Cast Iron fixed table: 21.6" x 35.3" / 896 x 548 mm
- Extension table (rear): 37 ½" / 952 x 896 mm
- Extension table (front): 12.6" x 32.7" / 830 x 320 mm
- Main saw blade (Max.): 305 mm
- Main saw bore: 30 mm
- Max. cutting height at 90 (355 mm): 4 13" / 90 mm
- Max. cutting height at 45 (355 mm): 2 3/4" / 63 mm
- Main motor power: 7.5 HP (3 ph)
- Main blade speed: 4000 rpm
- Scoring saw blade: 120 mm
- Scoring saw blade bore: 20 mm
- Scoring blade motor power: 3/4 HP (0.56 kw)
- Scoring blade speed: 8000 rpm
- Cutting width: 1,300 mm
- Main saw blade tilting adjustment: Manual (0 ~ 45°)
- Main saw height adjustment: Manual
- Scoring saw adjustment: Manual
- Dust collection system (For overhead guard): 4.72" 120/ 64 mm (120/100 mm)
- Shipping Dimension (Machine): 83" x 45 ½" x 44" (1782 lbs)
- Sliding table shipping dimension: 137" x 15 ½" x 14 ½" (432 lbs)

Dust collection:

- Port 1 diameter: 4"
- Port 2 diameter: 4"
- Minimum CFM needed: 1000 CFM

Blade:

- Main blade diameter: 400mm (15.75")
- Main blade arbor size: 1 3/16" (30 mm)
- Scoring blade diameter: 120mm (4 3/4")
- Scoring blade arbor size: 3/4" (20 mm)
- Max tilt: 45°
- Max depth cut: 3 15/16"
- Max cutting length: 120"

NOTE: Pictures and illustrations in this manual are ILLUSTRATIVE only and may not be the actual color, contain the same labels or accessories, and are intended only to illustrate the technical part.

2.2 Components



- | | |
|--------------------------------------|--------------------------------|
| 1. Mobile Arm | 17. Aluminum Table Guide |
| 2. Mobile Table Support | 18. Wood Panel Stopper |
| 3. Blade Tilt Control Panel | 19. Aluminium Guide Extensions |
| 4. Wedge Clamp | |
| 5. Main Table Lock | |
| 6. Wood Panel Clamp | |
| 7. Rear Extension Table Guide | |
| 8. Digital Display For Rip Fence | |
| 9. Rear Extension Table Guide | |
| 10. Rear Extension Table | |
| 11. Emergency Buttons/Switches | |
| 12. Control Panel | |
| 13. Dual Blade Protector Cover | |
| 14. Support Table | |
| 15. Scoring Blade Adjustment Handles | |
| 16. Measuring Tape | |

2.2.1 Mobile Arm

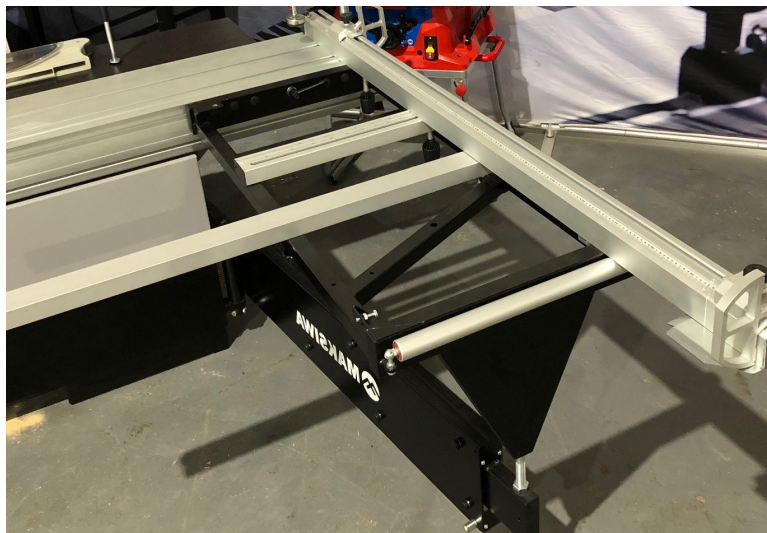

Enables greater cutting range and greater ergonomics for the operator.

2.2.2 Mobile Table Guide



It is used to support larger workpieces and make cross cuts. Can be placed throughout the movable table.

2.2.3 Blade Tilt Control Handle



It is used to tilt both saw blades manually.
The slope of the saw ranges from 0 to 45 degrees.

2.2.4 Control Panel

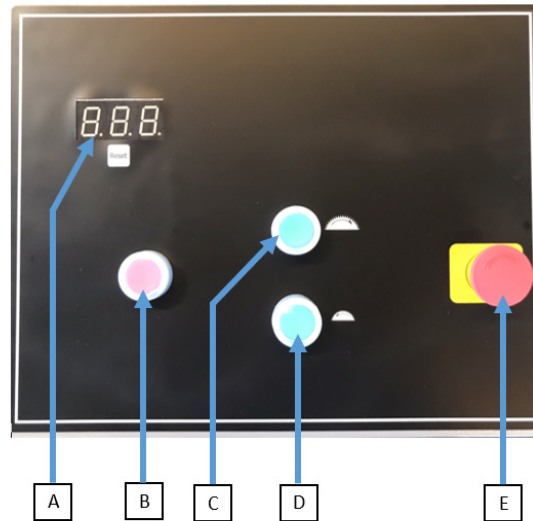

At the control panel you control all the functions and cutting devices of the machine.

A. Angle Display

B. Red button OFF: When pressed, the main saw and scoring blade are switched off.

C. Green button ON: When pressed, it turns on the main blade.

D. Green button ON: When pressed, it turns on scoring blade.

E. EMERGENCY button: This is a safety button. It must be released to operate the main and scoring blades. When it is pressed in the machine turns off.

2.2.5 Emergency Buttons/Switches



Control Panel



Under main table

The emergency switches are used to power the machine and turn it off.

1. Control Panel EMERGENCY Button: Powers the machine and the machine control panel.
2. Secondary EMERGENCY button. (Cuts power of the machine, located on the side of the main body).

2.2.6 Main Table Lock

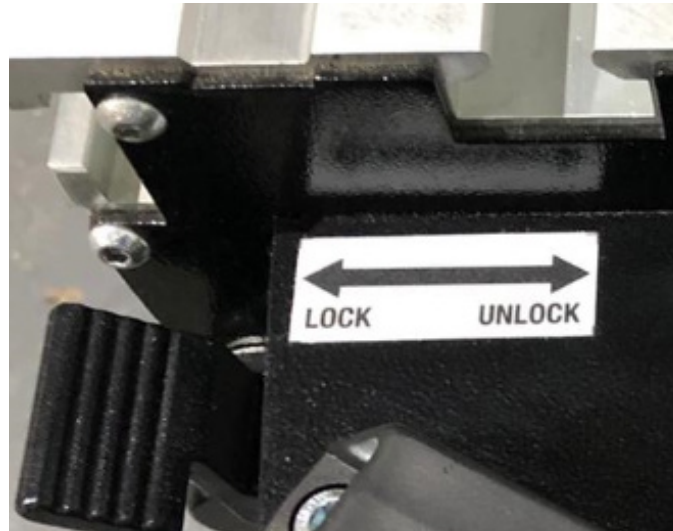

When applied it locks the movable table structure, when released it unlocks the movable table.

2.2.7 Sliding Table Handle



It is used to push the movable table during the cut.
Ensures greater operator ergonomics.

2.2.8 Adjustable Table Handle



It is used to push the movable table during the cut and It can be moved through the table.

2.2.9 Rear Extension Table

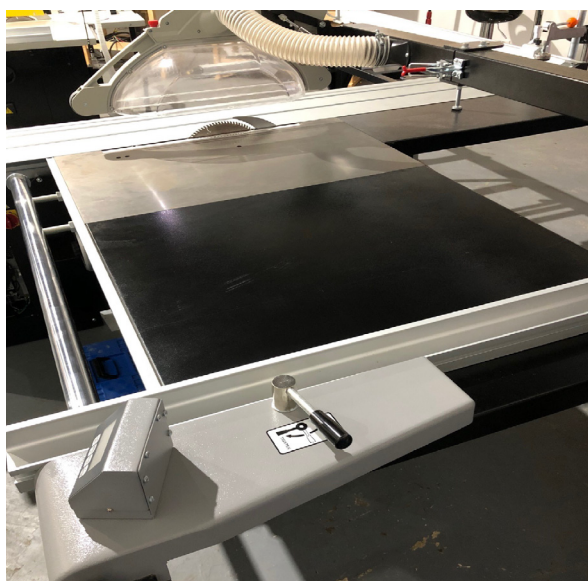

Provides an increase to the work area. It holds a ruler.

2.2.10 Rip Fence

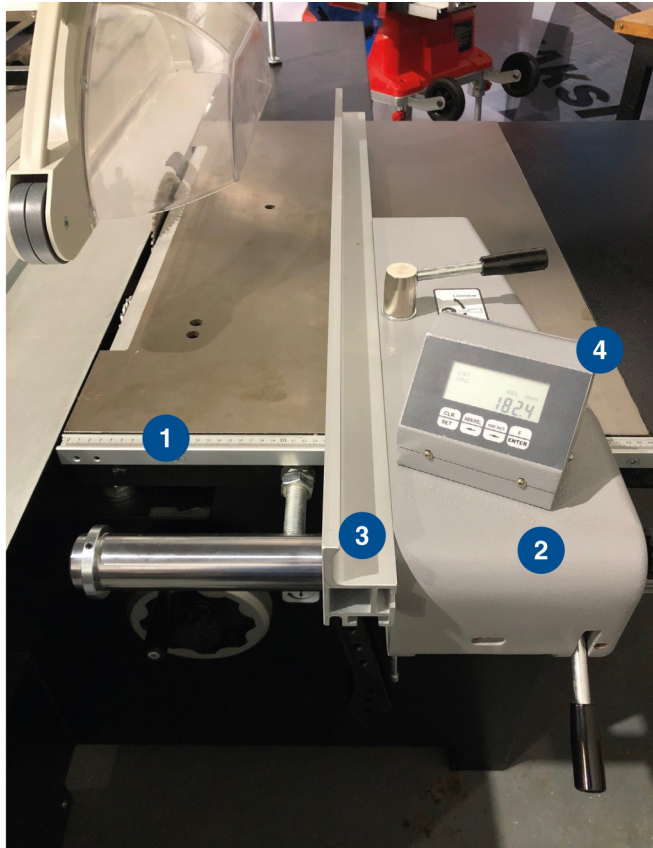

It is intended to be used as a reference to cut multiple pieces at the same measurement.

1. Guide ruler: It is fixed throughout the table.
2. Guide frame: Made of cast iron.
3. Aluminum guide: It is fixed to the guide frame and serves as a support for the workpiece.
4. Digital display provides increased accuracy.

2.2.11 Panel Pushing Handle



It is used to push the workpiece providing safety for the operator.

2.2.12 Blade Protector Cover



It has the function of protecting the operator against splinters and saw dust from cuts.

2.2.13 Dust Collection Port

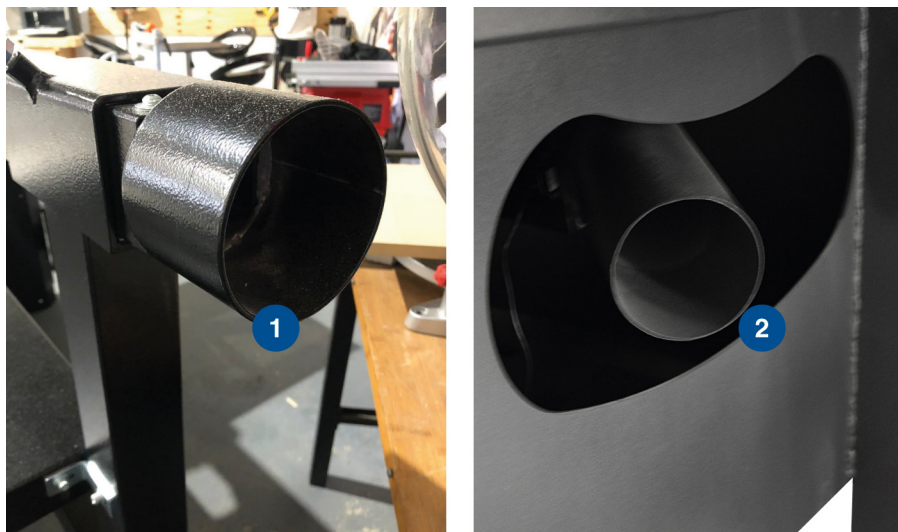

Its function is to collect residues and saw dust from cuts.
The two outputs have a diameter of 100 mm (4 in).

1. Outlet for upper dust collector: It is located in the saw protection cover.
2. Lower dust collector outlet: It is located on the side of the machine.

2.2.14 Support Table



Solid cast iron main table which is ground and polished.

2.2.15 Wood Panel Clamp



It is used to lock work pieces on the movable table.

1. Sheet Clamp
2. Wedge Clamp

2.2.16 Aluminum Table Guide



Made of aluminum, the movable table guide has the function of adjusting the workpiece in the position the operator wishes and It has a ruler.

2.2.17 Scoring Blade Adjustment Location

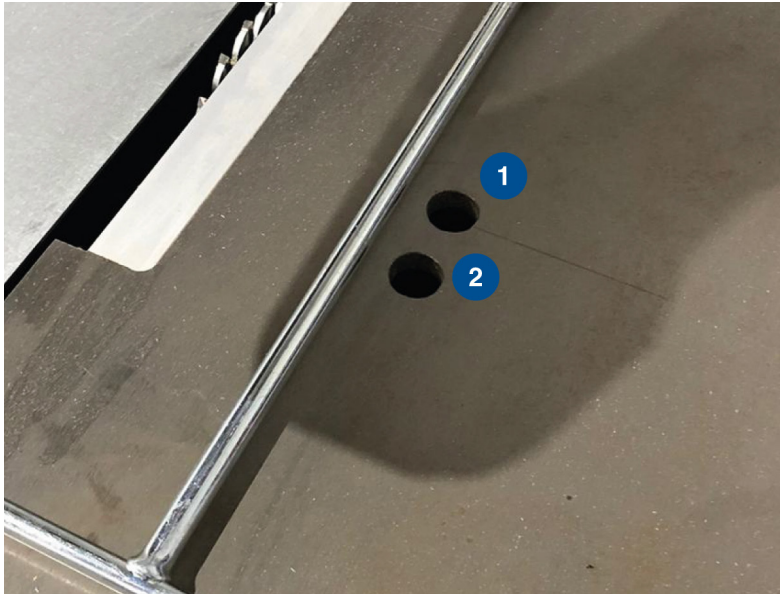

They have the function of regulating the scoring blade.

1. Adjust the scoring blade high. Clockwise = up, counter clockwise = down.
2. Adjust the scoring blade alignment to the main blade (clockwise = out, counter clockwise = in)

2.2.18 Wood Panel Stopper

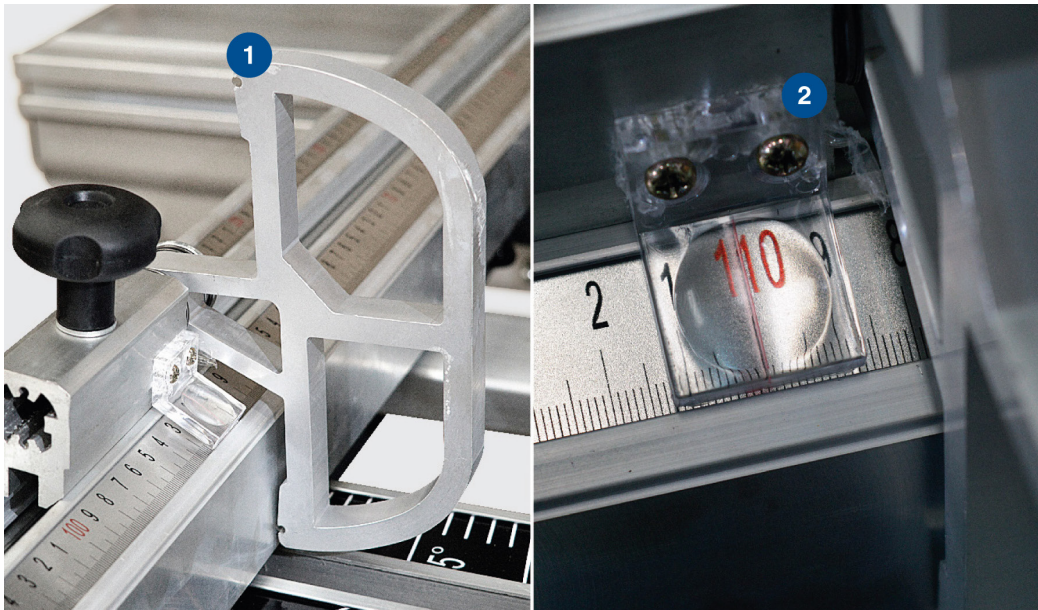

It is located on the aluminum guide of the movable table.

It has the function of locking the workpiece in the position desired by the operator.

Contains 2 units.

1. Workpiece lock: When lowered, it locks the position of the workpiece.
2. Magnifier: Increases the view of the measurement chosen by the operator.

2.2.19 Main Blade Height Adjustment Handle



It is used to raise the main blade height.

2.2.20 Aluminium Guide Extensions

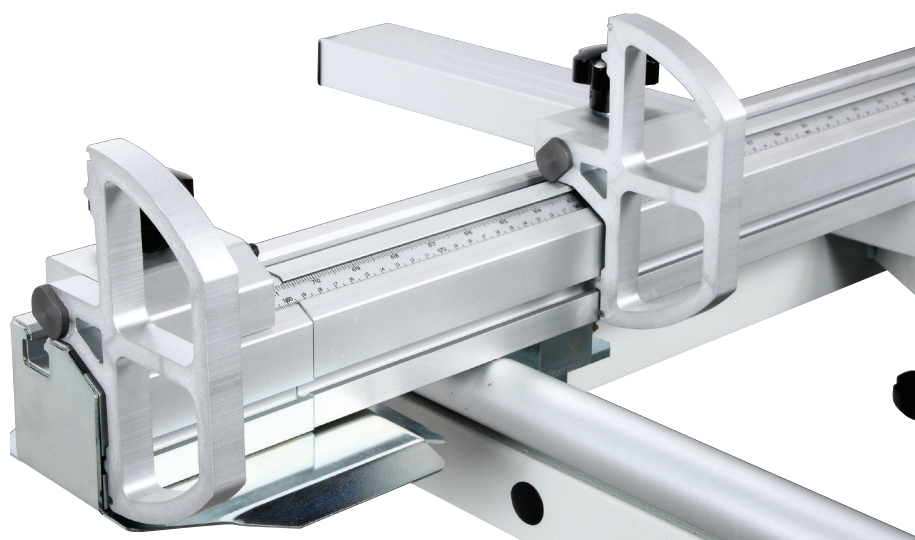

It has the function of extending the work area.

2.2.21 Digital Readout

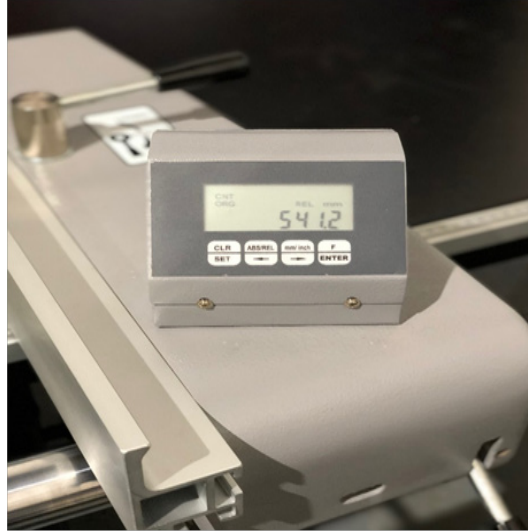

1. Magnetic measuring
2. Battery life 1 year
3. Multifunctional LCD display
4. Resolution 5 μm , 10 μm , 100 μm , 1 mm
5. Max. gap: 2.5 mm
6. Absolute offset counters
7. Programmable offset setting
8. Programmable angular measurement
9. Radial / Diameter mode
10. Programmable coefficient setting
11. Battery level indicator
12. Parameters stored in permanent memory
13. Correct zero point
14. Absolute / Incremental conversion
15. Inch / mm conversion
16. Calibration
17. Real time self-diagnose

Specifications:

1. 8 digits LCD display
2. Batteries: AA 1.5VDC type x 2
3. Standard cable length: 3M
4. Operate by 4 keys
5. Operating speed: 8m/sec max
6. Repeatability: 0.01mm
7. Accuracy: (+/- 0025 + 002 L) mm
8. Operating temperature: 0°~ +60°C
9. Thermal expansion: $\alpha=16 \times 10^{-6} / \text{k}$
10. Storage temperature: -20°~+70°C
11. Humidity: max95%rF
12. Front panel: 96 w x 72 h x 45 d (mm)
13. Back panel: 91.5 w x 66 h x 40 d (mm)
14. Cut out: 93 w x 67 h (mm)

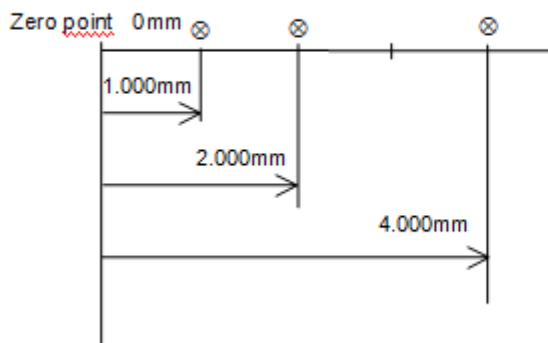

ABS/REL definition:

ABS (absolute)



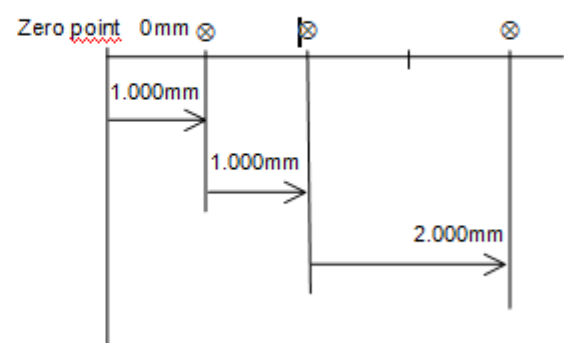

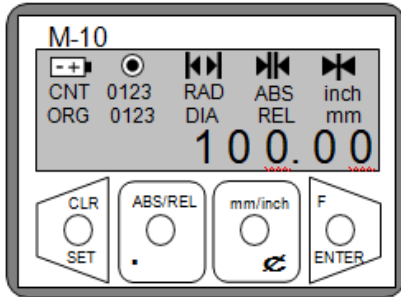
REL (incremental)





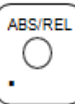

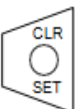
Front Panel and LCD Display:
Keyboard

 When pressed, the symbol  appears on the display

 Select mm/inch/deg mode (deg=degree measurement)

 Select ABS/REL mode

 1. REL mode: clear display value
 2. ABS mode: load origin value
 (Quick load)

LCD display

| | |
|---|---|
|  | Low battery |
|  | Process angular measuring |
|  | The gap is too narrow between sensor and tape |
|  | The gap is too big between sensor and tape |
|  | Enter parameter setting mode (by pressed "F" key) |
| CNT | REL counter (default) |
| CNT 0123 | REL counter 0/1/2/3 |
| RAD | Radius function |
| ABS | Absolute mode |
| inch | Unit: Inch |
| ORG | Default absolute counter number |
| ORG 0123 | Current absolute counter number |
| DIA | Diameter function |
| REL | Relative measuring mode |
| mm | Unit: mm |
| 100.00 | Current position display |

Load datum values:
A. Description: To load current value according to working piece.

Ex: The current display position: 100.00mm, the actual position: 200.00 mm



Step 1. Be sure in ABS mode. "ABS" will show on the display.

Note:

1. Press  to switch ABS/ REL mode.

2. If failed to switch, please check F9 (enable / disable key).



Step 2. Press and hold  till  show up.

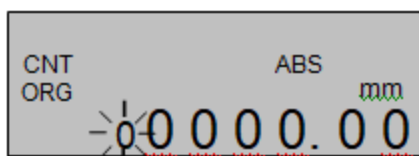

(0 positive / - negative)

Step 3. Press  immediately WITHOUT releasing value.

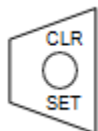

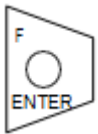

to see the current original.

Press  or  to select/shift digit.

Press  to complete and return to original setting.

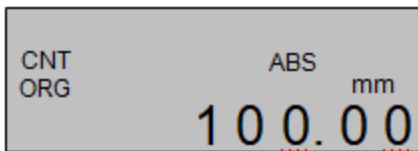
B. Load datum:



Step 1. Press  to enter ABS mode. "ABS" will show on the display.

Note:
1. Press  to switch ABS/ REL mode.

2. If failed to switch, please check F9 (enable / disable key).

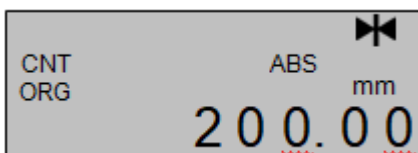

Step 2. Press and hold  till  show up.

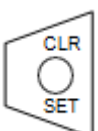
Press  immediately and new datum on the display and complete.

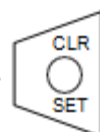
Note: If display "Origin", press  to exit.

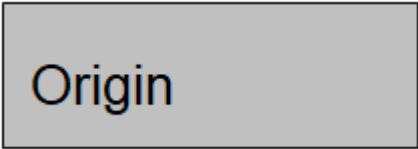
C. Troubleshooting:

Origin

- Display: "Origin" or other words:

Excluding: Press  to exit.



CNT
ORG 0000.00 mm

- Display: "0" or digit is blinking:

Excluding: Press  and 

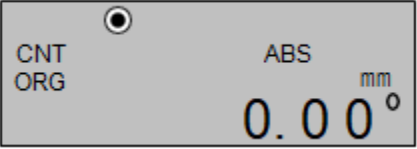

CNT
ORG ABS 0.00°

- Display: "0.00°"

Excluding: Press 

Select counting direction (+/-)

Description: To select the counting direction.

Ex: The current display position: 100.00 mm, the read head move forward and value decrease (99.68 mm) like to increase the value, follow the steps below:

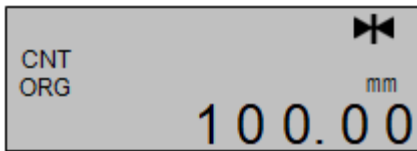

Step 1. Press  and hold till  show up to enter parameter setting (after 5 seconds).





Step 2. Press

Excluding: Press  display “dir”.

Note: Press  to select parameter.

Step 3. Press  display current counting direction.

Press  or  to select the direction.

Step 4. Press  to complete.

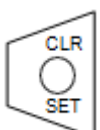

Step 5. Press  to exit.

Note: Please reload origin datum values.

Set device resolution

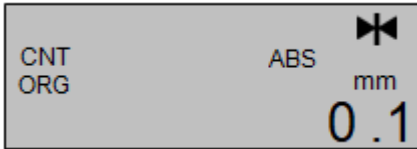
Description: Set M-10 resolution: 1 mm / 0.1 mm / 0.01 mm / 0.005 mm, please follow the steps below:



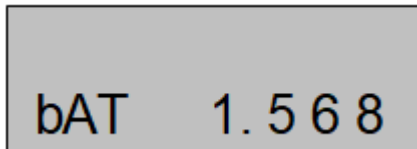

Step 1. Press and hold  till  show up and press 

Note: Please DON'T release  If display origin, press  to exit.

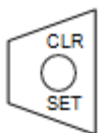

Step 2. It will auto-exit when bat show for 2 sec.

Press  +  at the same time, enter set resolution program.



Step 3. Press  to select resolution.

Sequence:

→ rES 0.005 → rES 0.01 → rES 0.1 → rES1



Step 4. Press

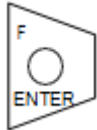

to exit.

Note: Please kindly confirm the resolution.

Pre-set 4 programs

A. Description: M10 provides 4 programs (ABS) for user to pre-set cutting length and count accordingly.

Ex: P1 = 20 mm, P2 = 30 mm

ORG: Default, offset: 0 ORG 1 / 2 / 3



Step 1. Press and hold

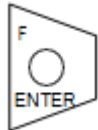

till  show up.

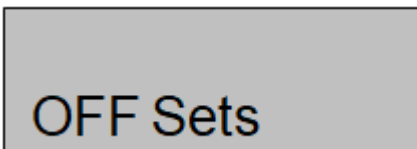

Step 2. Press



LCD display Offsets.

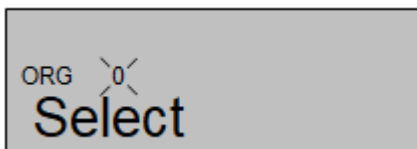

Step 3. Press



to enter parameters function.

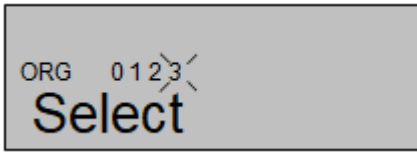

Step 4. Press   to select.



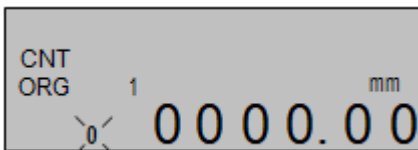

Step 5. Select ORG1 → P1

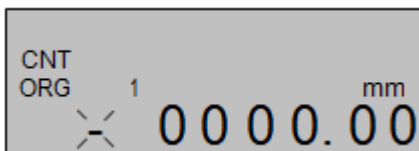

Step 6. Press  (0 or — blinking).

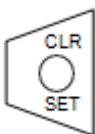

Step 7. Press  to select +/- or set numeric. Press  to shift.

Note: Select 

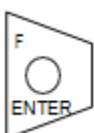
Step 8. Confirm the numeric. Press  returns to ORG.

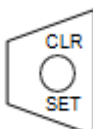
Step 9. If proceed to set, please repeat step 4 ~ 8. Press  twice to exit.

B. Execute pr-set programs (Only in ABS mode)

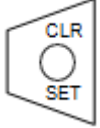

Step 1. Press and hold  till  show up. Press  to select ORG.



Note: If display origin, press  to exit.

Set speed

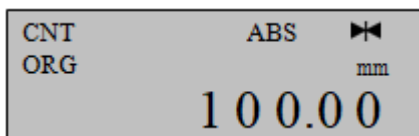
A. Description: Provide 6 mode of speed: SPEED 0 / SPEED 1...SPEED 5 Low speed, low battery life.

| Parameter | SPEED 0 | SPEED 1 | SPEED 2 | SPEED 3 | SPEED 4 | SPEED 5 |
|----------------------|---------|---------|---------|---------|---------|---------|
| Speed (mm/sec) | 0.27 | 0.41 | 0.82 | 1.63 | 3.29 | 8.33 |
| Battery life (years) | 2.78 | 2.56 | 2.28 | 1.83 | 1.42 | 0.95 |

B. Operation step

Step 1. Press  and hold till  show up to enter parameter setting (after 5 sec.).

Display: Origin (Adjusting parameter)



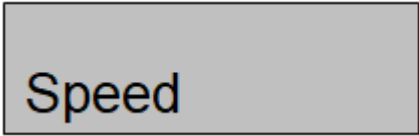

Speed

Step 2. Press



four times, display Speed.

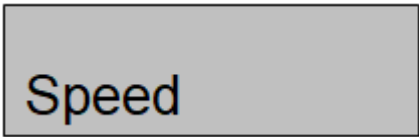

Speed

Step 3. Press

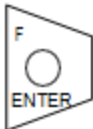

display origin parameter. (Confirmed Speed 3). Press

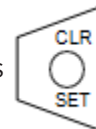

to select speed.

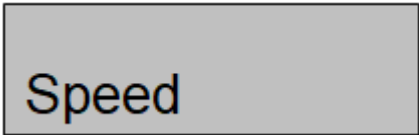

Speed

Step 4. Press



to display Speed.

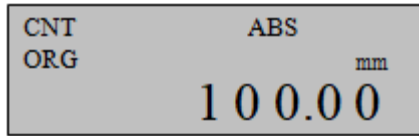

CNT ABS
ORG mm
100.00

Step 5. Press



to exit.

Calibration (Adjust gap between sensor and tape)

A. Description: For better accuracy, please execute "Setup" function immediately after installed sensor each time.

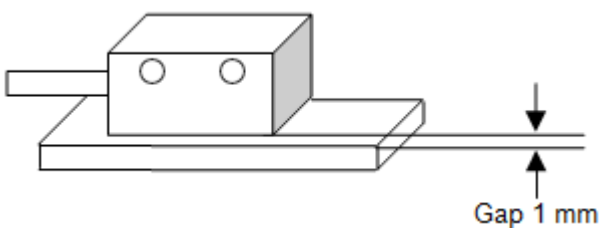

Step 1. Fix sensor, keep 1 mm gap from tape. (RECOMMENDED).

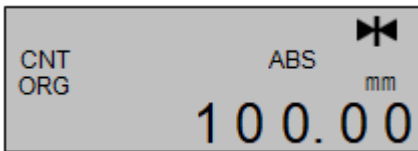

Step 2. Press and hold  till  show up to enter parameter setting.

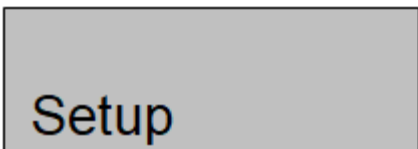

Step 3. Press  till display "Setup".

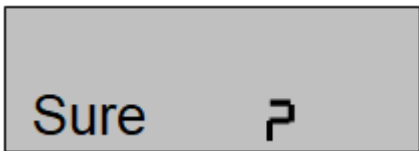

Step 4. Press  to confirm enter parameter.

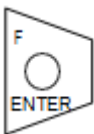

Step 5. Press  to calibration.



Step 6. Moving the slider at low speed. (Required distance around 120 mm).

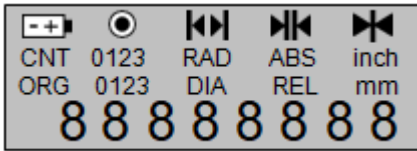

Step 7. When completed, all symbols and digits will blink and return to the operation display.

Note: Please execute load datum values immediately.

B. Troubleshooting:



Display: Sensor and  Possible cause: The gap is too small. Excluding: Increasing gap and press



twice and repeat step 6 to complete.

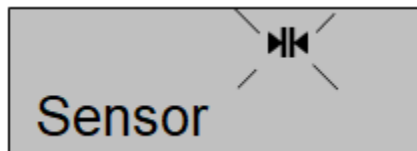

Display: Sensor and  Possible cause: The gap is too big. Excluding: Decreasing gap and press



twice and repeat step 6 to complete.

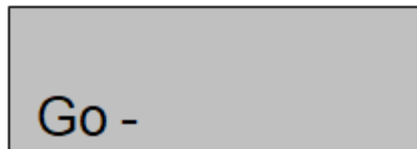

Display: Go / Go- / Go-- Possible cause: 1. Gap is too big. 2. The mounting surface is Not flat.

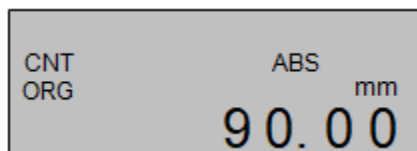

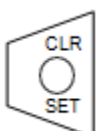
Press  to exit or end during calibration.

Enable and Disable Specified Parameter

Description: Select enable and disable parameter, follow the steps below:

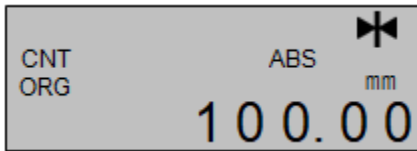

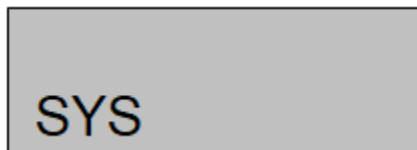

Step 1. Press and hold  till  show up to enter parameter setting.

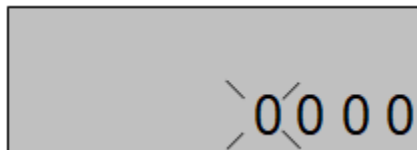

Step 2. Press  and hold till SYS show up.

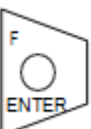

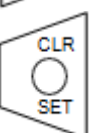

Step 3. Press  and enter password: "2201" (Digit is blinking).

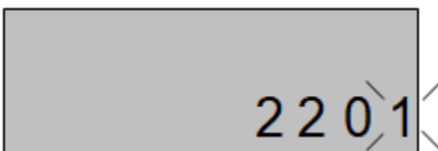
Step 4. Press  to set value. Press  to select digit.

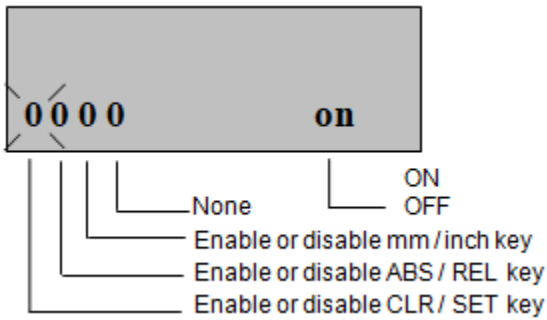

Step 5. Please confirm the password. Press  and enter parameter function.

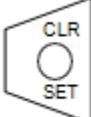

Step 6. Press  to switch on / off. Press  to select parameter.



Step 7. Press  to select on / off.

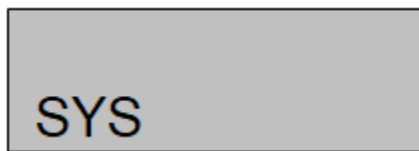

Step 8. Press  and display SYS.

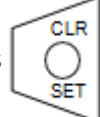

Step 9. Press  to exit.

Parameter Setting

Step 1. Press and hold  till  show up.

Step 2. Press  to select parameter. Note:

1. To switch Origin / dir / SYS / REL.

2. Press  to exit.

Appendix - Parameter

| Parameter | Display | Description | Default | Remarks |
|-----------|-------------------|-------------------------------------|---------|---------|
| 1 | Origin | Load datum value | 0 | |
| 2 | Direction | Select counting direction (\pm) | dir - - | |
| 3 | Off Sets | Set tool diameter | 0 | |
| 4 | Angular | Enter semidiameter value | 0 | |
| 5 | Scaling | Diameter / semidiameter | rAd | |
| 6 | Linear Correction | Linear correction | 1.00000 | |
| 7 | Speed | Speed | 3 | |
| 8 | Setup | Fine adjustment distance | | |
| 9 | SYS | Enable/disable Parameter | 0000 | |
| 10 | REL | Software version | | |

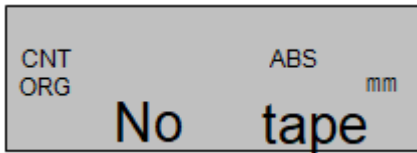
Troubleshooting

- A. Display: no tape. Possible cause: The gap is too big. Excluding:
- Please check the gap between sensor and tape. Refer “Calibration”.
 - Sensor over the travel.
 - Tape is loose.
 - Refer “Installation guide”

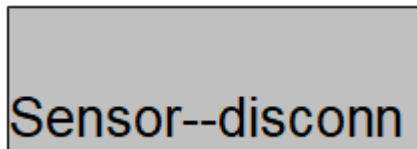

- B. Display: Sensor disconnected. Possible cause: No sensor Excluding:
- Please check the 8 Pin connector.
 - Wire broken.
 - Take off the battery (wait 10 sec) Re-install.

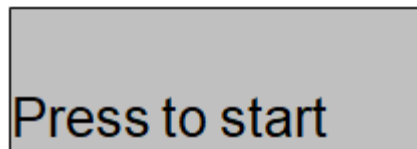

- C. Display: Press to start Setup Possible cause: No sensor Excluding:

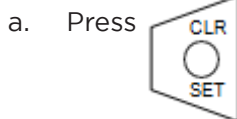

- Refer “Calibration”
- Loose contact.
- Chang the wire and sensor.

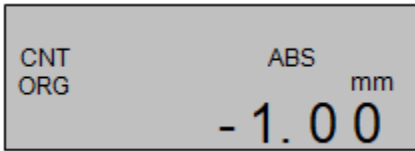

- D. Display: 0-1.00 mm. Possible cause: No sensor Excluding:
- Wire broken.
 - Sensor broken.
 - Change the wire and sensor.



- E. Display: Enable. Possible cause: Low battery. Excluding:
- Please replace the batteries.

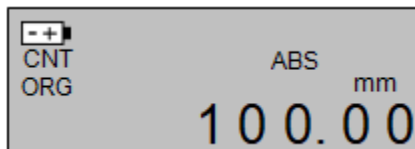

- F. Display:  Possible cause: Low battery. Excluding:
- Change the battery.
 - M-10 will lose current value.
 - Refer to “How to change battery.

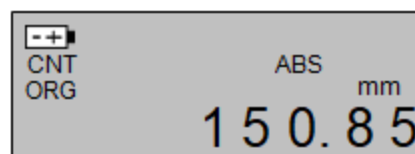

- G. Display: Digit is blinking. Possible cause: Low battery. Excluding:
- Change the battery.
 - Refer to “How to change battery.
 - Measurement error.

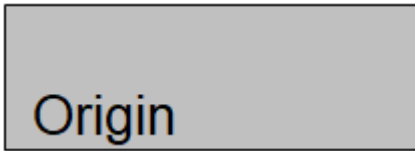

H. Display: "Origin" or other word. Possible cause: Enter parameter function. Excluding:

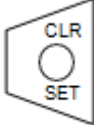
- a. Press  to exit.

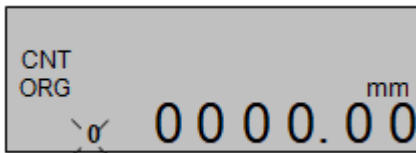

I. Display: "o" or other digits and blinking. Possible cause: Enter parameter function. Excluding:

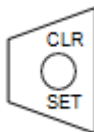
- a. Press  and 

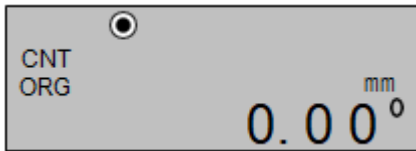

J. Display: "0.00°". Possible cause: Enter angular mode. Excluding:

- a. Press  to exit.

How to change battery

Battery type: AA (1.5V) x 2 pcs. When LCD displays with  symbol, please change 2 new batteries to ensure M-10 performance normal.

- A. Release the screws back of battery holder and remover the cover.

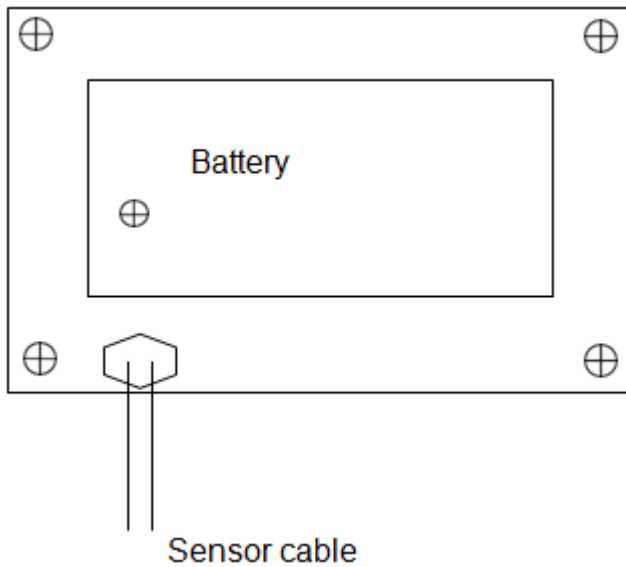

B. Slide the cover to left.

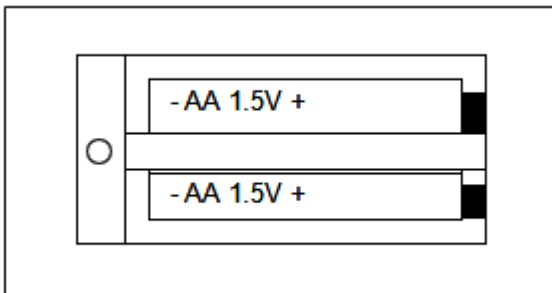

C. Strongly recommend to replace battery one by one.
Please Do Not change 2 batteries at the same time. It will cause M-10 lost current value. All parameters will be stored.

D. After change battery, please lock the cover.

Note:

1. If lost current value, please reload origin datum values.
2. Battery: 1.5V DC AA type x 2 pcs.

Installation Guide

The magnetic tape consists of three components:

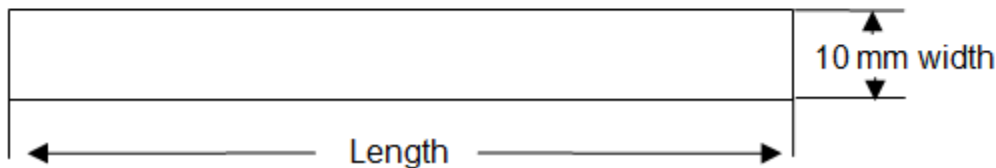
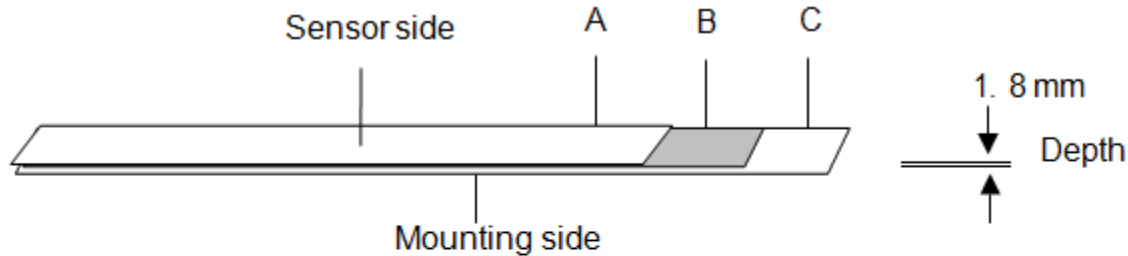

- A. A magnetized, highly flexible synthetic tape.
- B. Flexible steel tape. A and B are already factory-bonded.
- C. To keep the flexibility for transport and installation, the third part C, also a steel tape is delivered separately. It serves for mechanical protection of the synthetic tape and must be stuck on the magnetic synthetic tape after installation.
- D. There components of tape: depth: 1.8 mm, width: 10 mm.

Installation:

- a. Ensure to apply tape on clean, dry and plain surface.
- b. Be sure the tape adhesion on surface.
- c. Please apply the tape with ambient temperature: 21-38°C
- d. We recommend to make a chamfer on the machine to install the tape.
- e. If cut a edge can stable the tape.

Cable:

- Distance more than diameter 50 mm.
- Must be away from inductive and capacitive interference source as conductor, relays, motors, switch power pack clocked controllers, etc.
- Must be kept a distance to interference sources.

Sensor:

- Allow some fault when install the sensor.
- Attend the position when install the sensor.

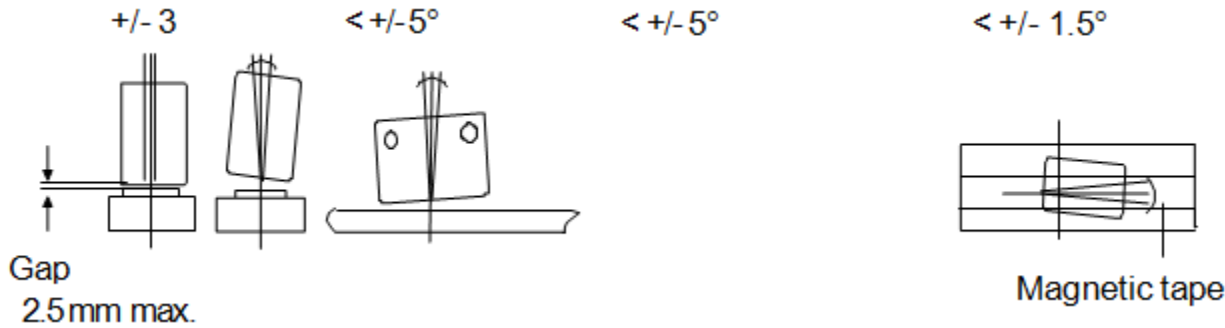

Recommend Gap between tape and sensor: 1 mm

Unit: mm

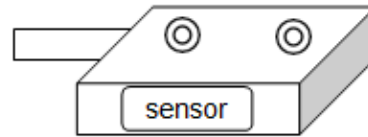
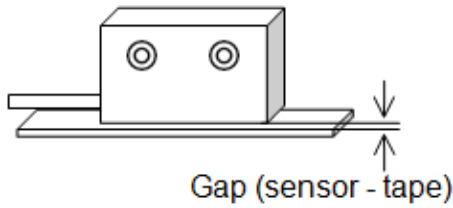

※Attached the sensor on the tape with "senor" sticker.

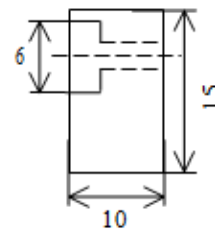
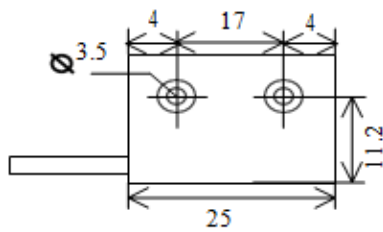

External dimension

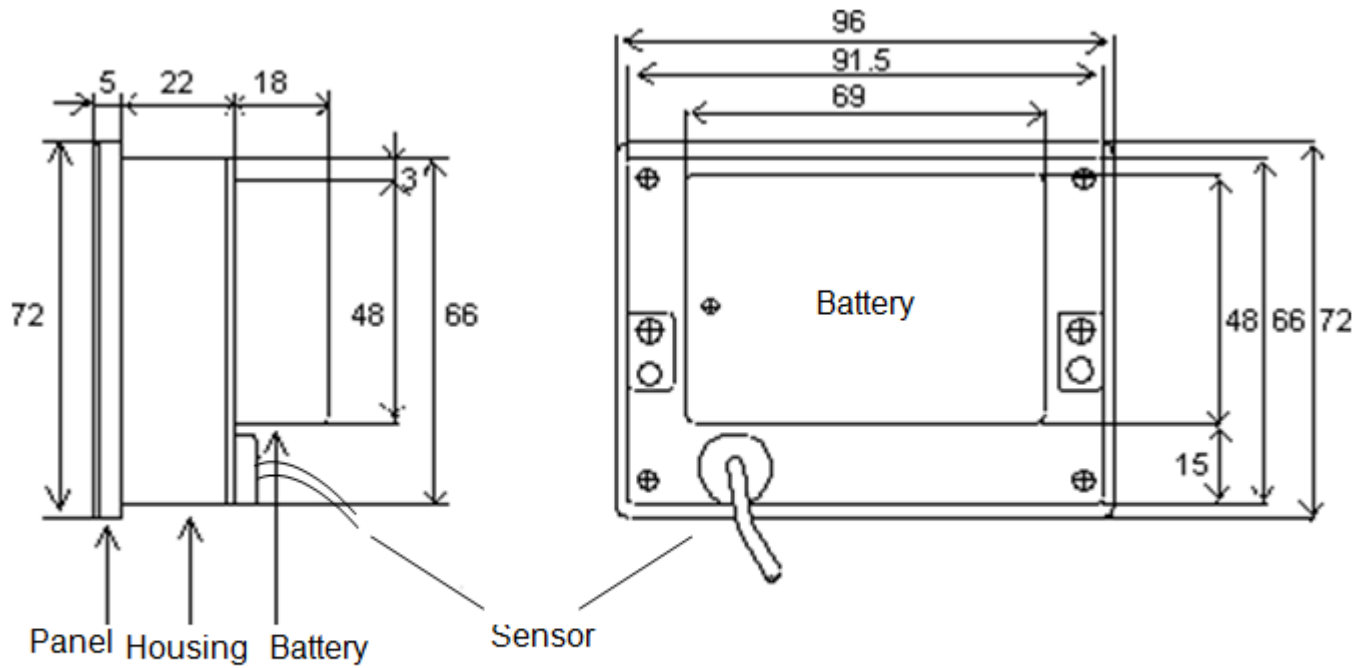

(Unit: mm)

Mounting drawings

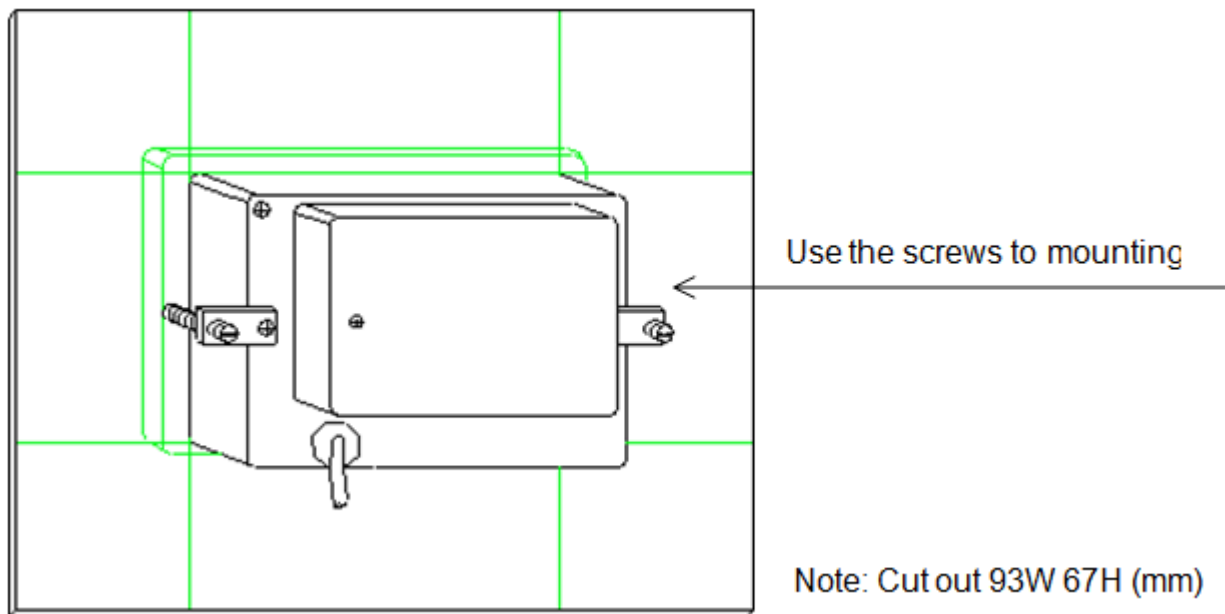

3 Installation

The following sections will deal with the adjustments necessary for the smooth operation of the machine and shall refer to the term that accompanies the illustrations. For this, you must know the components and know where they are.

3.1 Electrical Installation

- The electrical installation should be carried out by qualified and trained personnel.
- The main connections must be made at the terminal box.
- Installation of the power cord in the machine should only be done by a electrician.
- Connect the machine's power wires to an electrical outlet: 220 V.
- We recommend the installation of circuit breaker be according to the model you have purchased.



Fig. 1: Access the power supply box, add main wire 220V.

Fig. 2: The configuration should be from left to right. L1, L2 and ground. Once all wires are hooked up, turn on main power switch.

Fig. 3 and 4: If it does not start up check the emergency buttons, the front panel or the rear access door. If rear door or red blade guard is open, blades will not spin.

Electrical:

3 phase model 220 V:

Main motor:

- 24 Amps
- 7,5 HP
- Non loaded blade speed: 4.000 RPM

Scoring motor:

- 6 Amps
- 3/4 HP
- Non Loaded blade speed: 8.000 RPM

It is recommended to consult an electrician.

Use a minimum 12 to 10 gauge wire.

CAUTION: To prevent electrical shock, any maintenance or repair to the electrical system should be done only by a trained electrician using OEM parts.

CAUTION: Do not connect the unit to the power outlet until this manual is read and understood.

3.2 Assembly

- For packaging reasons, the machine is not completely assembled.
 - If you notice any damage caused by shipping, while opening the package, notify your supplier immediately. Do not operate the machine.
 - Estimated assembly time: 2 to 4 hours.
1. Carefully remove the machine from the crate and any loose components in the interior of the machine, then remove plastic coverings from all components.



Fig. 1 and 2: Unpacking the machine.

Fig. 3 and 4: Removing the components.

2. Remove all the Allen bolts from the Support table. After that, install the cylindrical bar of the fixed table.

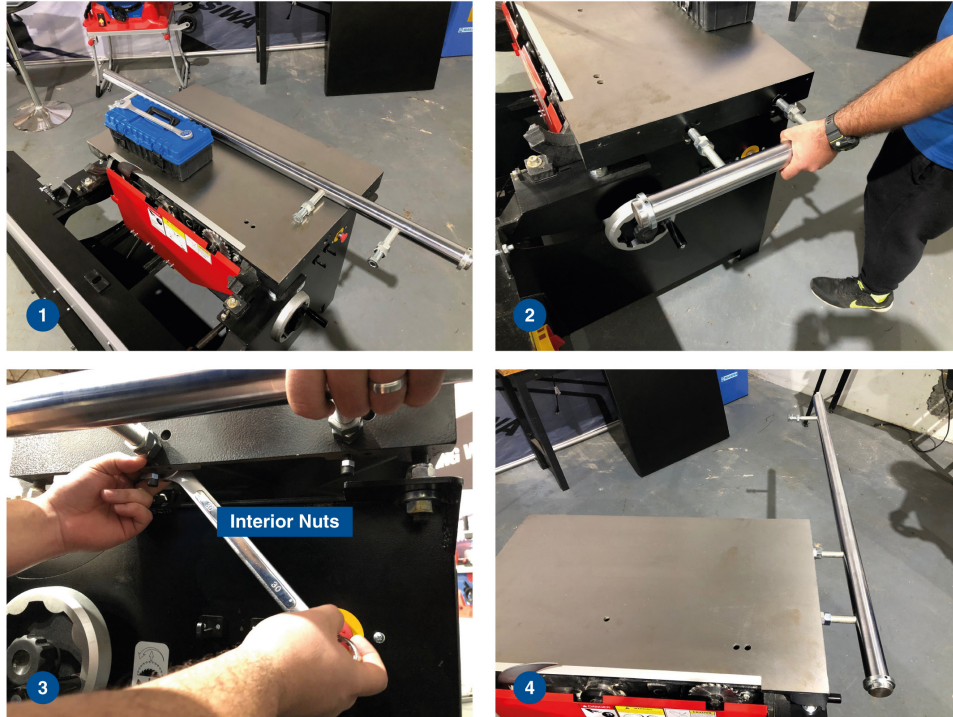

Fig. 1: Inside the tool box (included) use the 30 mm Combo wrench to tighten the interior nuts.

Fig. 2: Place the rail on the correct position.

Fig. 3: Tighten the nut on the inside of the machine.

Fig. 4: Rail fixed.

3. Install the rear table.



Fig. 1: Use three bolts washers and lock washers to fix the rear table on the main body of the machine.

Fig. 2: Remove one nut and one washer from the far end of the round rail.

Fig. 3 and 4: Place table on the correct position.

Fig. 5 and 6: Tighten three bolts under the table and make sure it is leveled.

4. Install lower arm, standing support arm and upper arm.

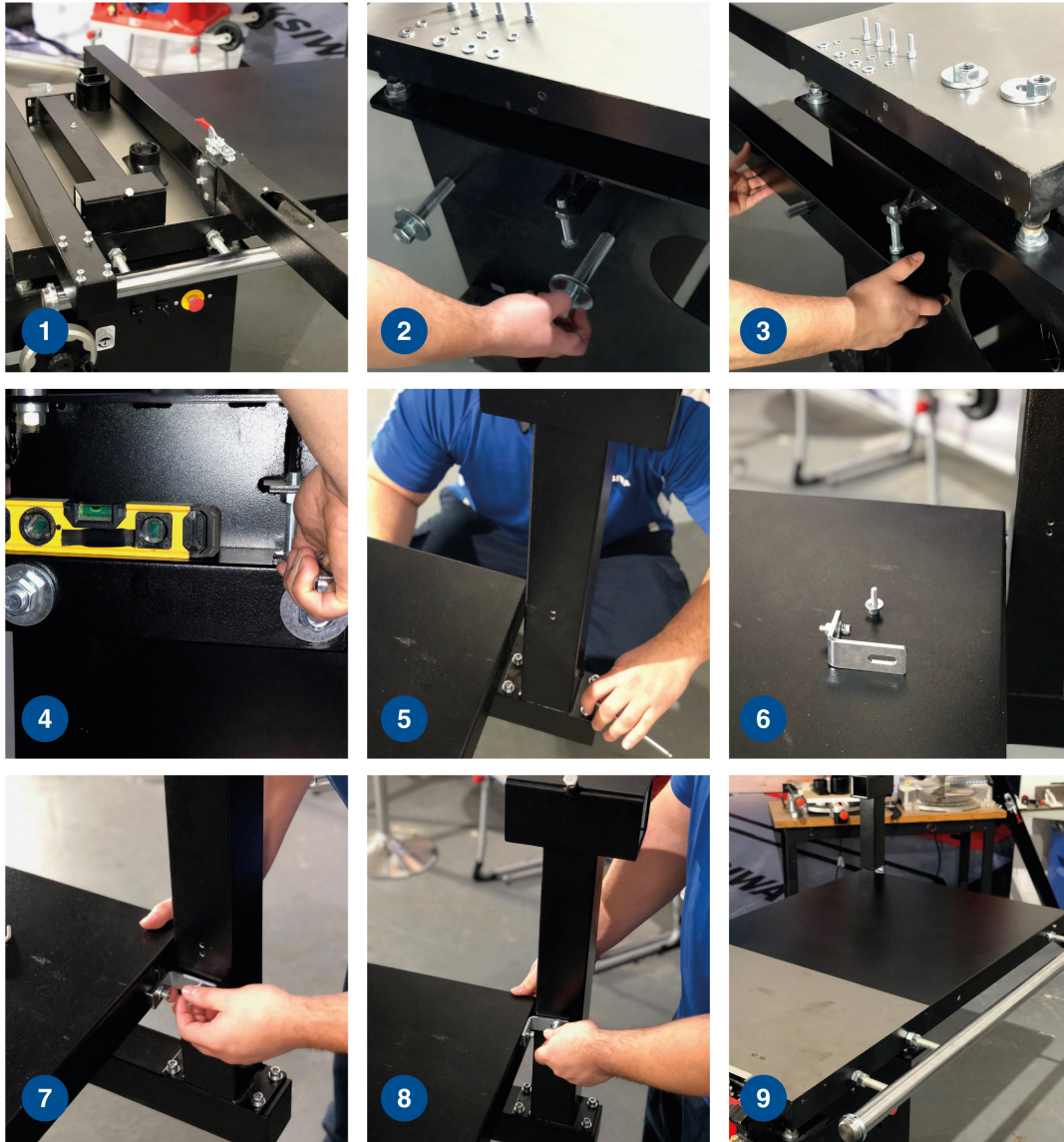

Fig. 1: Separate all parts needed.

Fig. 2 and 3: Remove mounting bolts and install lower arm.

Fig. 4: Make sure arm is leveled and tighten mounting bolts (don't tighten all the way, so you may make adjustments as needed. Once adjustments are completed, tighten all the bolts).

Fig. 5: Install standing support arm.

Fig. 6, 7 and 8: Add brackets and finish tighten all bolts.

Fig. 9: Standing support arm installed.

5. Install the upper arm and dust collector ports.

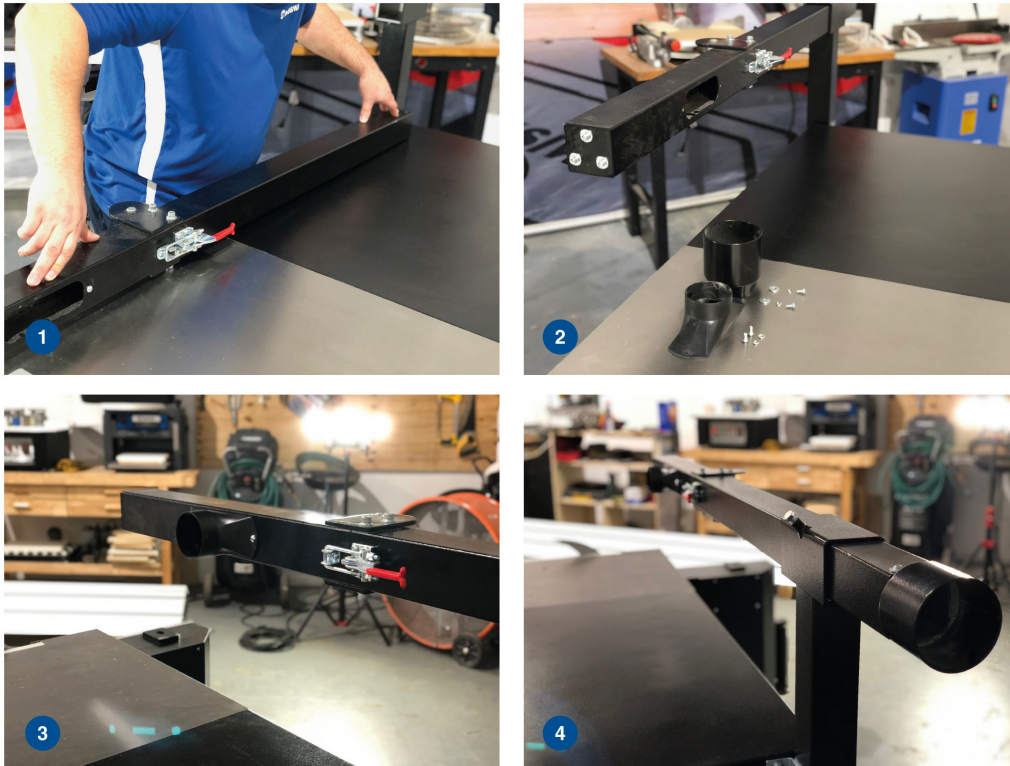

Fig. 1: Attach upper arm on standing arm support.

Fig. 2: Install dust collector ports.

Fig. 3 and 4: Tighten all bolts.

6. Install the Support table ruler.

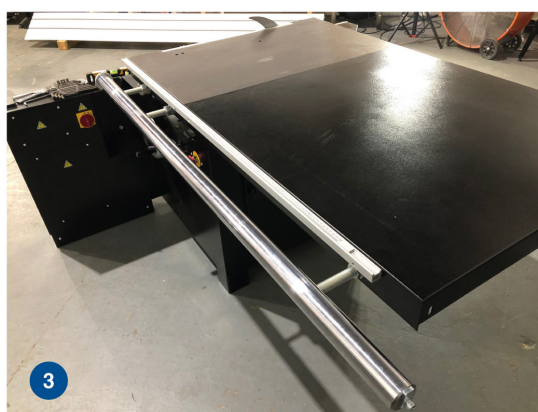
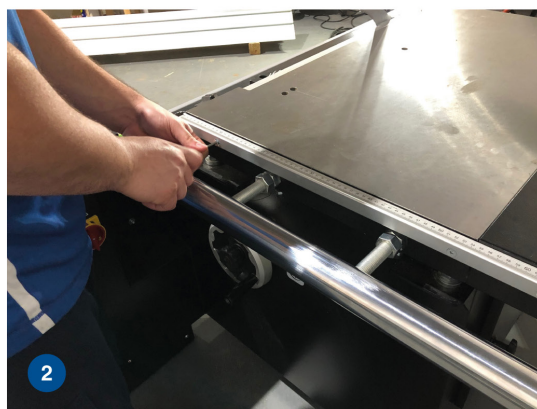
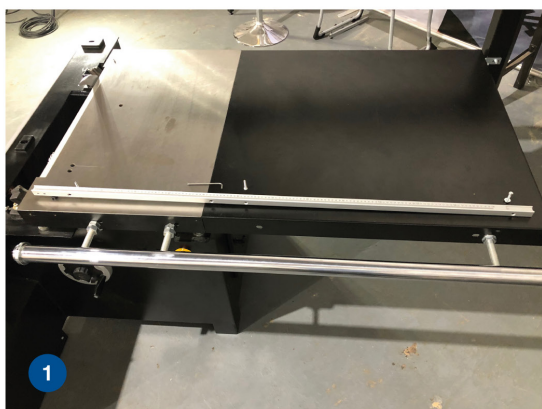

Fig. 1: Position the ruler guide on the support table.

Fig. 2: Tighten the bolts.

Fig. 3: Installed guide.

7. Install rip fence and rip fence tape.

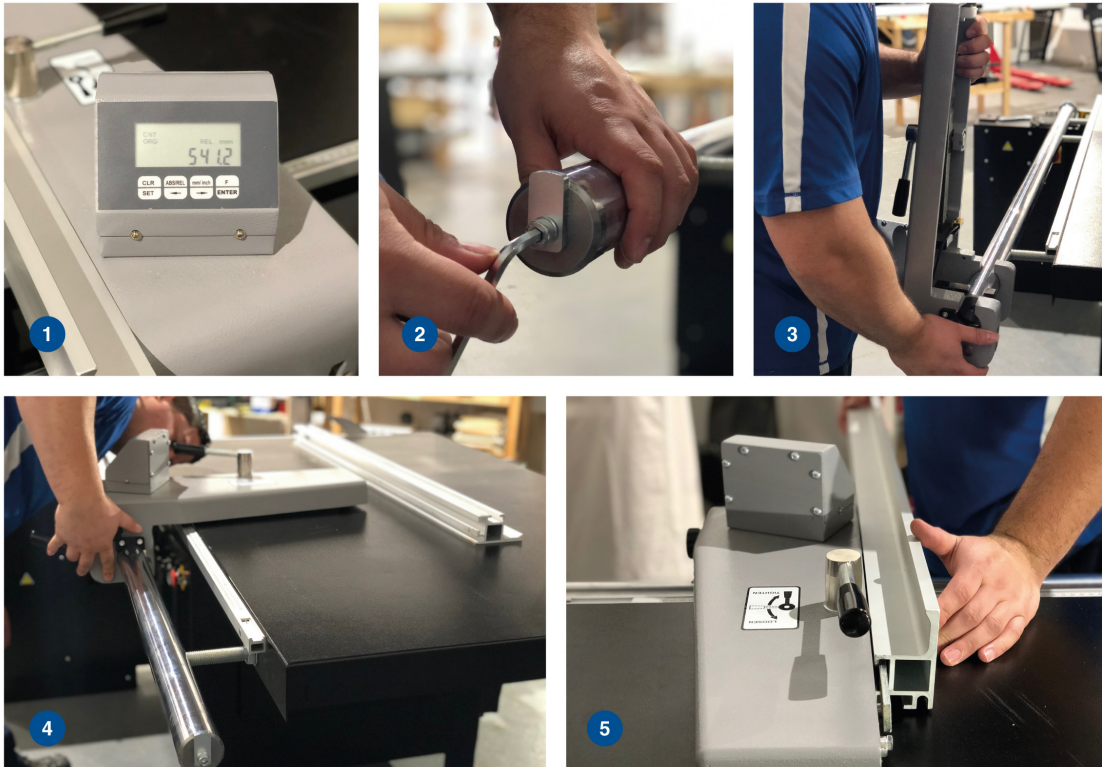

Fig. 1 and 2: Add rip fence by into the side rail, by removing rear stopper.

Fig. 3 and 4: Slide rip fence into place and reinstall the stopper back.

Fig. 5: Install rip fence tape. start install the fence from the back, loosen lock handle.

8. Install side table.

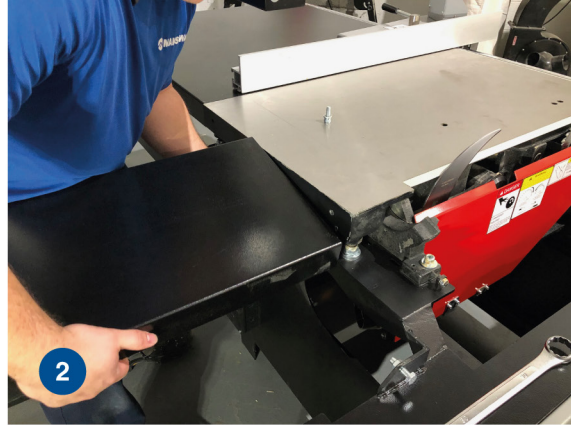
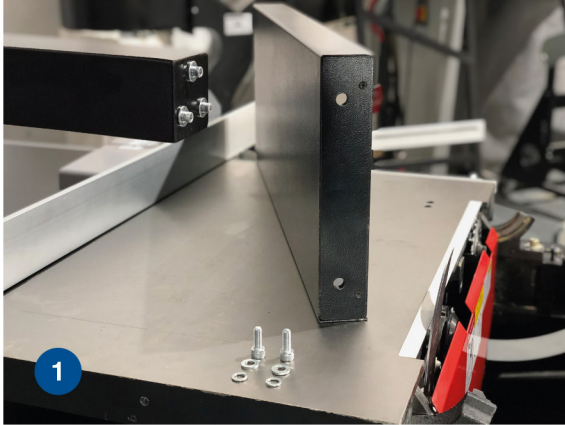

Fig. 1, 2 and 3: Align side table with main body of the machine. Make sure it stays flush.

Fig. 4: Tighten two allen bolts.

9. Install main blade.

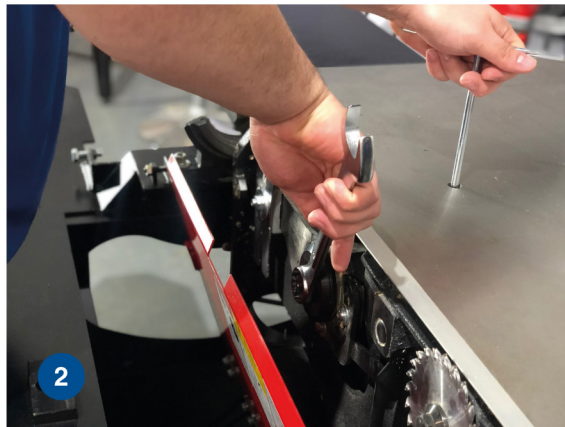
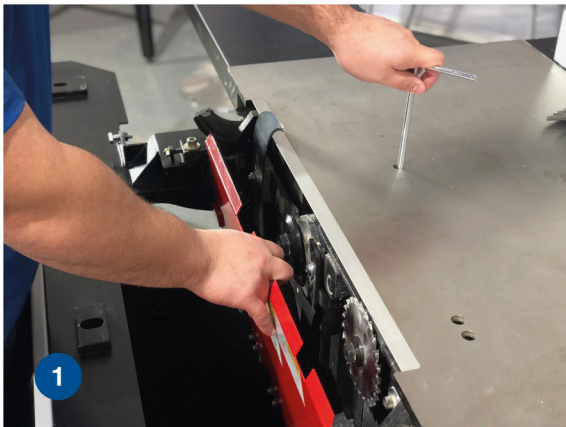

Fig. 1 and 2: Hold it down from the top and loosen side nut clockwise.
Fig. 3 Tighten the nut.

10. Install the sliding table.

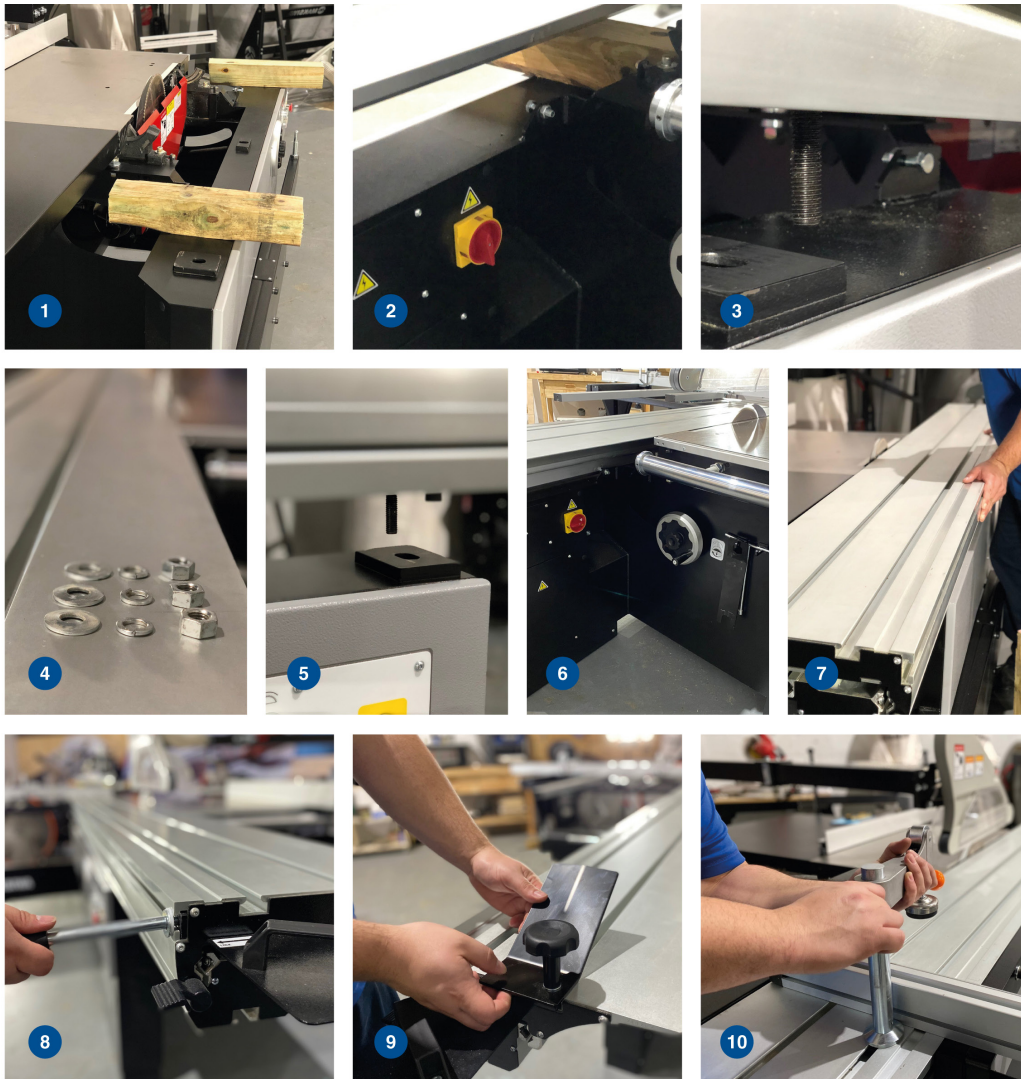

Fig. 1: Add two 4x4 wood pieces where the sliding table will be.

Fig. 2: Make sure table is in lock position and place it on top of the wood pieces. (Do not touch the alignment bolts over the shut off button, this was already set on the factory).

Fig. 3 and 4: Align bolts with the holes to be tightened. Remove wood pieces one by one, once all out push the table against the alignment bolts.

Fig. 5: Add the three nuts, three washers and three lock washers on the table bolts.

Fig. 6: Remove the upper electrical port to access the bolt. Once the table is aligned tighten all 3 bolts.

Fig. 7: Table is installed.

Fig. 8: Install side handle on sliding table.

Fig.9: Install wedge clamp.

Fig.10: Install sheet clamp.

11. Install the saw guard into the frame.



Fig. 1 and 2: Attach the saw guard to the frame.

Fig. 3: Install dust collection hose.

Fig. 4: Tighten all bolts.

Fig. 5 and 6: Installed protector.

12. Install support table.



Fig. 1: Attach the support table on the lower arm.

Fig. 2 and 3: Install the adjustment bracket on the fence and tighten bracket.

Fig. 4: Install handles to fence brackets, but do not tighten completely.

13. Fence adjustment.

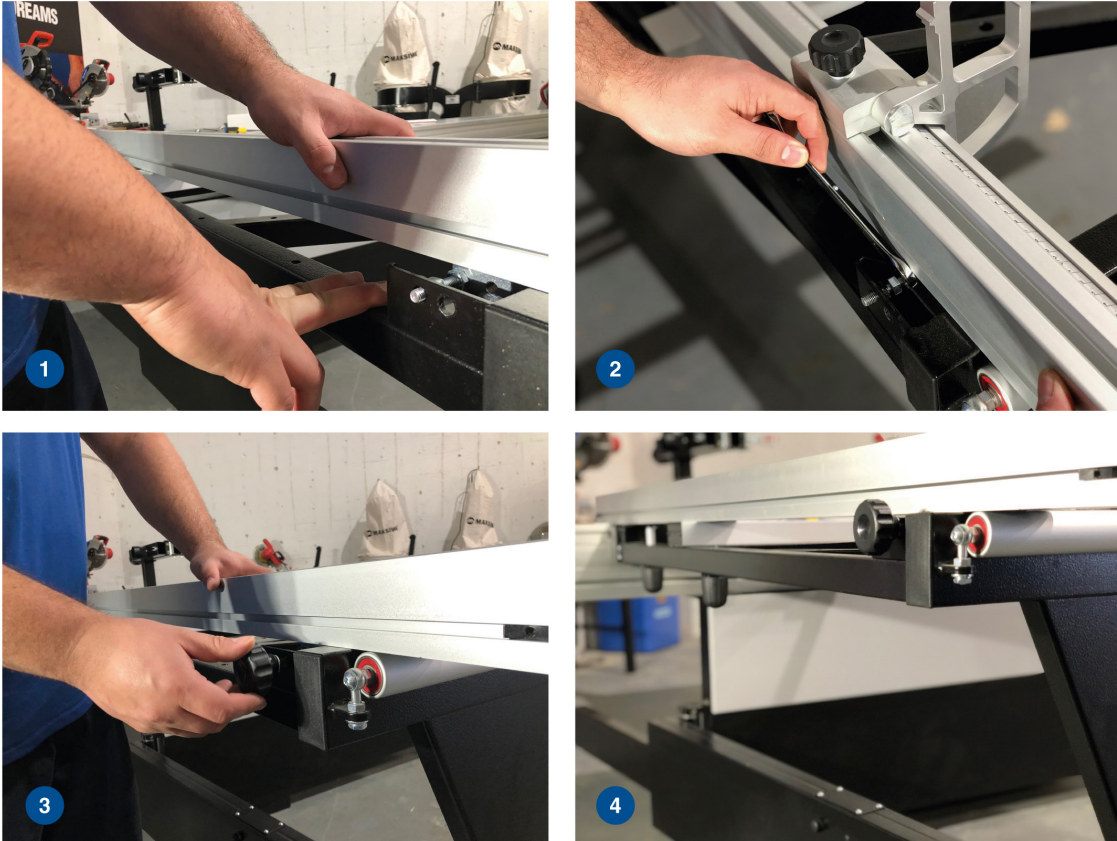

Fig. 1 Slide fence to the 90° stop bolt and check for alignment .

Fig. 2 If necessary adjust 90° stop bolt until fence is squared.

Fig. 3: Install knob on the square block and tighten until the 90 bolt and block are touching. Do not over tighten.

Fig. 4: Table installed.

14. Wood Panel Stopper.

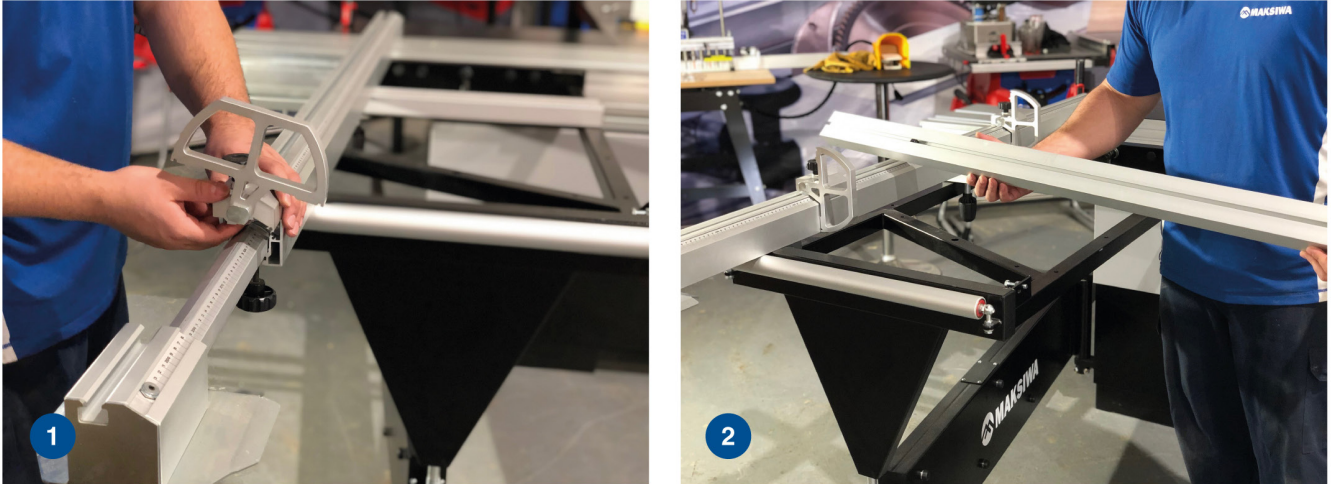

Fig. 1 and 2: Fit the wood panel stopper on the aluminum tab and tighten the handles.

15. Ready! Your BMP.3200.IR PLATINUM Sliding Panel Saw is properly installed.



4 Operation

- Before operating the machine, make sure that the electrical installation was properly installed.
- The electrical installation should be done by a trained electrician.
- NOTE: Although your saw cuts wood and many other non-ferrous materials, we will limit ourselves to discussing only the cutting of wood. The same guidelines apply to other materials.
- DO NOT USE ABRASIVE BLADES.
- The smoothness of any cut depends on a number of variables. Factors such as the type of material being cut, blade type, blade sharpness and cutting rate contribute to the cutting quality.
- When you want smoother cuts for frames, install a sharper blade (80 or more carbonated teeth).
- A slower and steady cut rate will produce the desired results. Make sure that the material does not vibrate during the cut.
- The BMP.3200.IR Platinum cuts internal MDF sheets.
- Proper positioning of the body and hands during operation will make cutting easier, accurate and more secure. Never place your hands close to the cutting area. Put your hands in position no closer than 6 inches from the blade. Hold the piece firmly against the table and the guide during cutting.

4.1 Main Blade Adjustments

Lift the cutting blades by turning the handle counterclockwise. The saw has to be approximately 20 mm (3/4 in) from the height of the sheet to be cut.



Fig. 1: Saw blade raise handle.

Fig. 2: Illustration of the height of the saw blade in relation to the workpiece.

4.2 Scoring Blade Adjustments

The function of the scoring system is to perform a surface cut, such as a “scratch” on the workpiece before the main blade cuts. This allows the cut to come out clean, with no chips on the workpiece. It is an optional system; the operator can choose to work with it or without it. To use it first, lift the cutter by turning the left knob counterclockwise. The height should approximately be 5 mm (3/16in) above the table.



Fig 1 and 2: Scoring blade adjustment location. Adjust the scoring blade height. Clockwise = up, counter clockwise = down. Adjust the scoring blade alignment to the main blade (clockwise = out, counter clockwise = in).

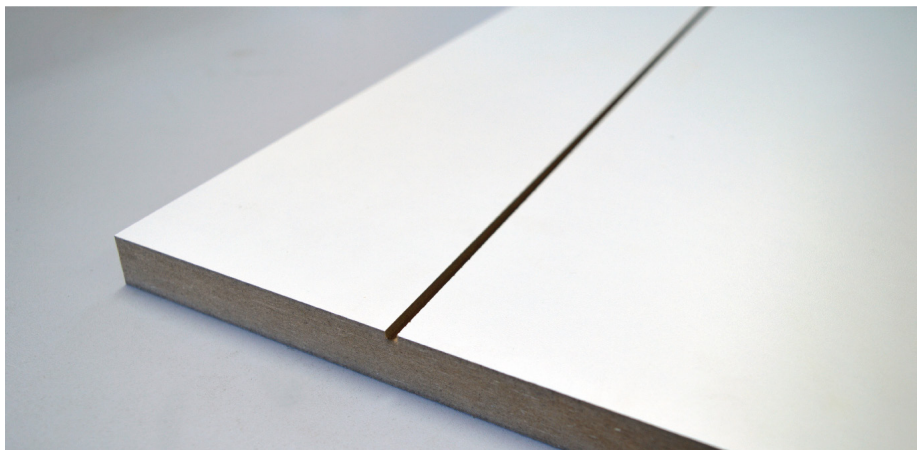

Your alignment should look like this.

4.3 How to Cut at Different Angles

The BMS.3200.IR Titanium can cut up to 45 degrees. To do this, turn the handle located on the front of the machine to the desired angle and check the angle on the digital display.

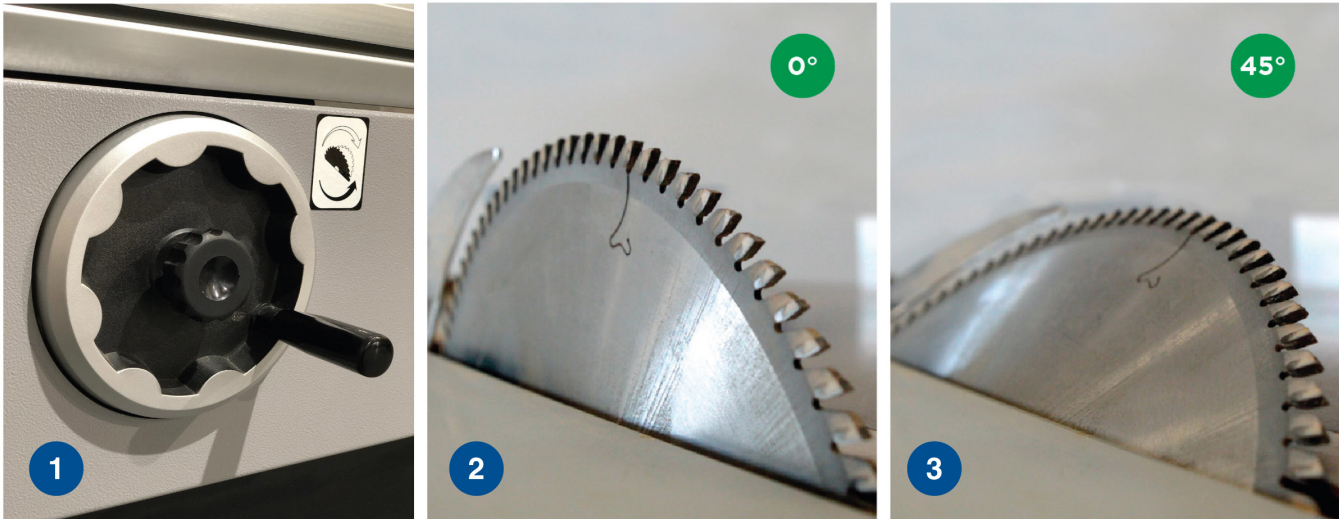

Fig. 1: To tilt blades loosen center knob and pull out handle. Turn clockwise to tilt 45, turn counter clockwise to go back to 0.

Fig. 2: Tilted 0 degrees.

Fig 3: Tilted 45 degrees.

4.4 How to Setup for Recurrent Cuts

Choose the measurement of the workpiece that you want to cut.

Lock the fixed table guide. Then push the piece against the table guide, If the operator wishes, he can secure the workpiece using the wood panel clamp.

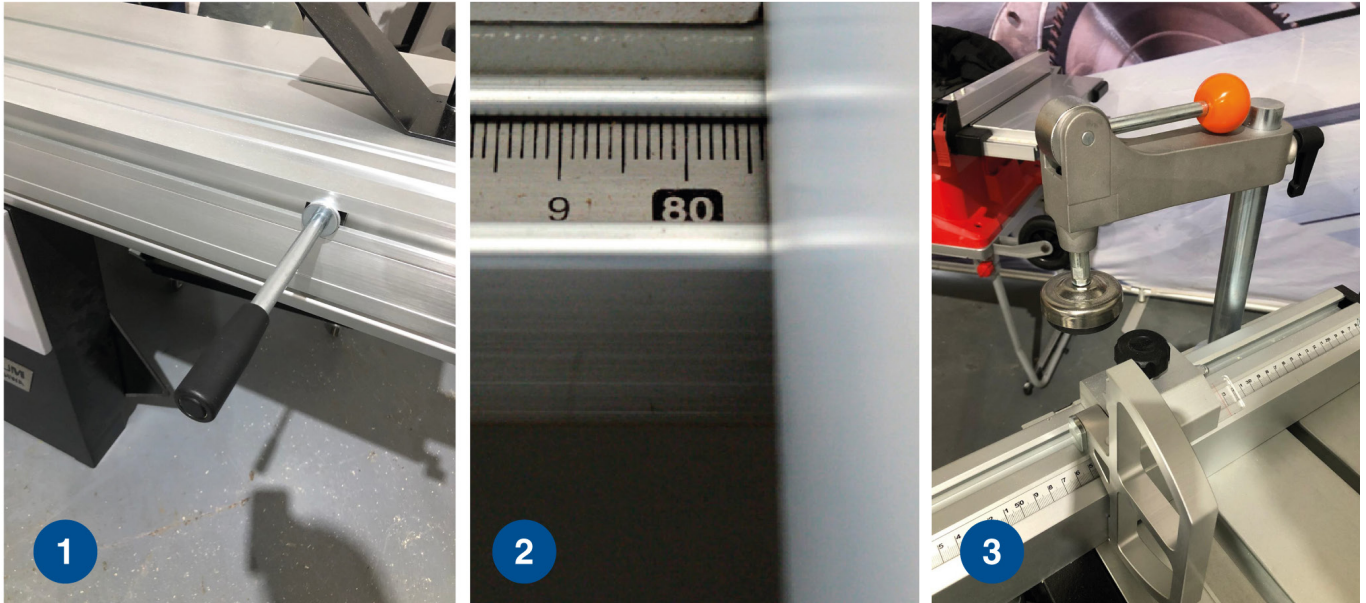

Fig. 1: Wedge clamp.

Fig. 2: Detail of the part on the ruler guide.

Fig. 3: Sheet clamp.

4.5 Running a Piece

Turn on the saw and unlock the table, slowly push it until the workpiece meets the saw blades.

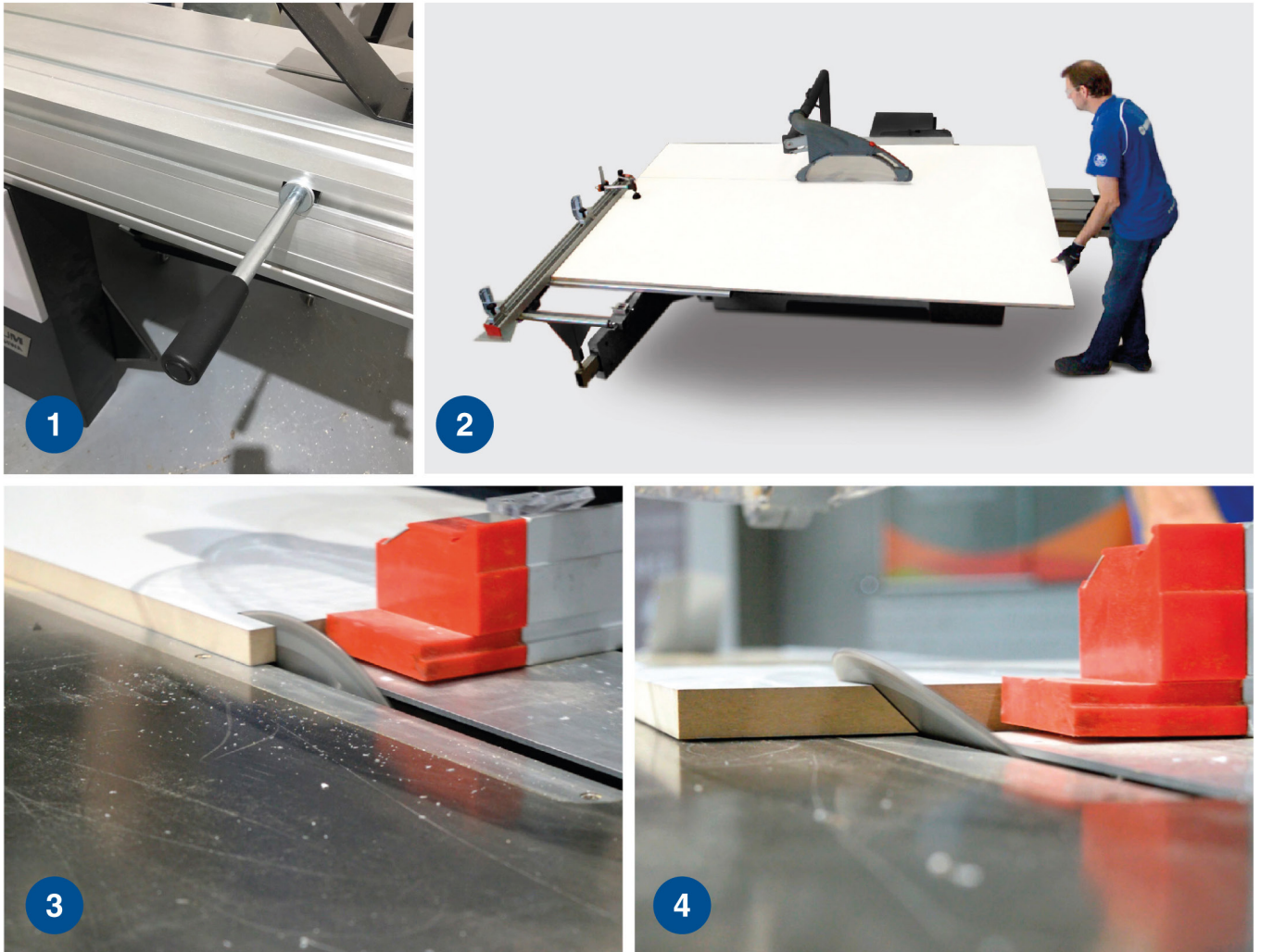

Fig. 1: Unlocking of the movable table.

Fig. 2: BMT.3200.IR Titanium cuts entire MDF sheets.

Fig. 3: Straight cut.

Fig. 4: Cutting at 45 degrees.

4.6 Cross Cutting

- Multi-piece cutting is not recommended, but can be done safely by making sure that each workpiece is securely attached to the table or the guide. A cross-section is made cutting the wood in the opposite direction to the fibers at any angle. A straight cross-section is done with the blade at 0°. Put the adjustable angle guide at zero, hold the wood firmly on the table against the guide. Turn on the saw. When the saw starts to gain speed (after approximately 1 second), move the piece gently through to cut the wood.
- Transverse cuts are made with the adjustable angle guide attachment at any angle other than 0°. This angle is often 45° to make corners but can be adjusted from 0° to 45°. After the desired angle is selected, be sure to tighten adjustable angle guide.

4.7 Cutting Frames, Boxes and Other Four-Sided Pieces

- To better understand how to cut these items listed below, we suggest you do simple projects using smaller piece until you develop enough experience with your saw.

| Number of sides | Angle of bevel or Square |
|-----------------|--------------------------|
| 4 | 45° |
| 5 | 36° |
| 6 | 30° |
| 7 | 25,7° |
| 8 | 22,5° |
| 9 | 20° |
| 10 | 18° |

- Adjusting the bracket to bevel the ends of two boards at an angle of 45° each produces a 90° angle. For this joint the arm of the bracket should be locked at 45°. The wood should be positioned having the flat on the table and the thin side against the guide.
- The following table provides the proper angles for a variety of shapes. The table assumes that all sides have the same length. For a format that is not in the table, use the following formula: 180° divided by the number of sides, is equal to the angle of the bevel or square.

4.8 Bevel Cuts

- A bevel cut is a cross section made with the cutting blade not perpendicular to the wood. To adjust the bevel, move adjustable angle guide and move the adjusting blade height as desired. Once the notch is at a desired angle lock the handle firmly.
- Beveled angles can be adjusted up to 45° to the left.

4.9 Support for Long Parts

- Turn off and unplug the saw. ALWAYS SUPPORT FRAGILE PIECES. Support long pieces using any convenient supports such as trestles or similar structures to prevent damage.
- SEE THE MAKSIWA CATALOG AND FIND PRODUCTS FOR THIS FUNCTION.

4.10 How to Adjust the Rip Fence

1. Thread 4pcs M12-1.75 x 115 studs into round rail.
2. Thread an M12-1.75 hex nut onto each stud and tighten the nuts against the round rail.
3. Thread an M12-1.75 hex nut and a flat washer half way onto each stud.
4. Insert the studs into the table. Tighten with an M12-1.75 hex nut, lock washer and a flat washer on each stud.
5. Slide the rip fence body onto the rail, then place the adjustable ring on the sliding table end of the rail and secure the ring with the set screw.
6. Thread the lock handles into the rip fence body and loosely install the fine adjustment knob. Place the end washer on the end of the rip fence rail and secure it with the M8-1.25 cap screw and lock washer.
7. Slide the alum. Rip fence onto the clamping plate and lock it with the handle on the top of the rip fence body.
8. Adjust the nuts on the outside of the table until the edge of the rip fence is parallel with the sliding table, aligning the fence with the edge of the sliding table.

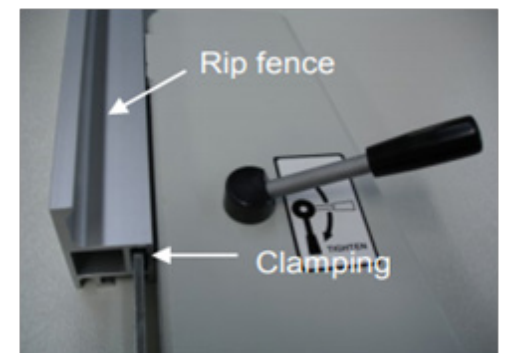

9. Check the height of the rip fence rail by sliding the rip fence along the rail and comparing the gap between the fence body and the table.
10. Adjust the height of the rip fence rail, then tighten all of the nuts against the table showed.
11. Check if the bottom of the rip fence rests on the surface of the table. If the rip fence does not rest on the table, then the fence is correctly adjusted, otherwise, loose the set screw and rotate the hex bolt to raise the roller, tighten the set screw to lock the ride height.

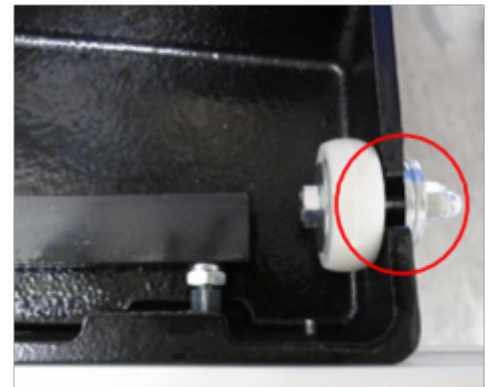
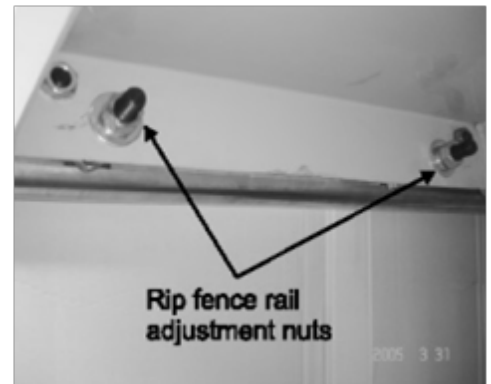

4.11 Main Blade

This saw is designed with 12" main saw blade, before you change blade sizes, the riving knife must be adjusted to match the size of blade you install.

1. Open the motor compartment and remove the foam shipping block and the red shipping brackets from the motors.
2. Move the blade tilt to 0° and raise the main blade as far as it will go.
3. Slide the table all the way forward to access the blade arbor and pull open the blade guard.
4. Use the arbor wrench to remove the arbor nut and arbor flange. **(The arbor nut has left hand threads and loosens by turning clockwise).** * Fix the saw blade by T Tool.



4.12 Fence Scale Alignment

Before operation, the 0" mark on the rip fence scale must be aligned with the right side of the blade to ensure that the rip fence measurements will be accurate.

1. Move the blade tilt to 0° (blade 90° to table), and raise the main blade all the way up.
2. Move the rip fence against the main blade.
3. Loosen the cap screws securing the fence scale.
4. Slide the fence scale to line up the first mark on the scale with the left edge of the rip fence and tighten the cap screw.
5. Set the rip fence at 1/8", slide the adjustable right against the rip fence body, and lock the ring in place. This will prevent the fence from hitting the blade.

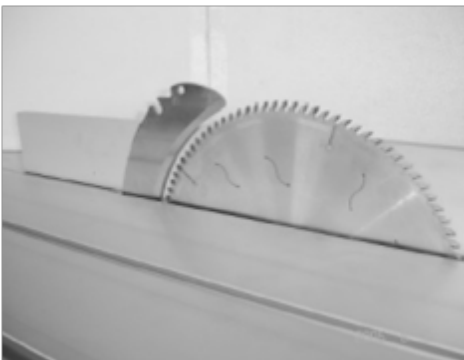

4.13 Riving Knife Adjustment

Whenever the blade is changed, then riving knife must be adjusted to 3mm away from the blade you install.

1. Disconnect the saw from power source
2. move the blade tilt to 0° (blade 90° to table) and raise the main blade as far as it will go.
3. Move the sliding table all the way forward to expose the internal blade guard that covers the blades and riving knife.
4. Pull the blade guard away from the riving knife to expose the mounting assembly.
5. Loose the riving knife center bolt, slide the riving knife away from the blade and slightly tighten.

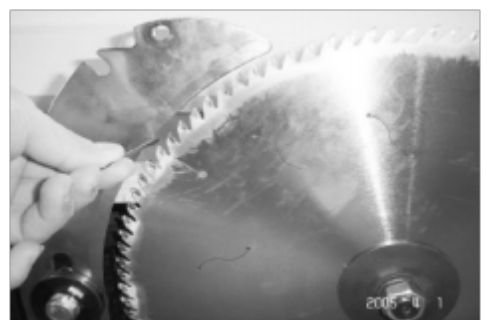
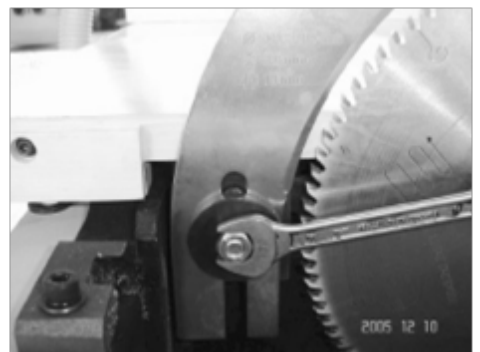

6. Position the riving knife about 3mm or 1/8" away from the nearest carbide tooth on the main blade.
7. Tighten the center bolt to secure the riving knife in position.
8. Move the blade guard back to its original position, and move the sliding table to center.

4.14 Changing Scoring Blade

1. Disconnect the saw from the power source.
2. Move the blade tilt to 0° (blade 90° to table), and raise the scoring blade all the way up.
3. Move the sliding table all the way forward to expose the internal blade guard that covers the blade and riving knife.
4. To hold the scoring use the U Tool and using the arbor wrench to remove the nut. (The arbor nut has right hand threads and loosens by turning counterclockwise).
5. Measure the main blade, and use the shims to stack the scoring blade set so the thickness matches the thickness of the main blade. (Only applicable if you use dado blades)
6. Install the blade set, re-install the arbor flange and the arbor nut, and tighten them against the blade set.
7. Move the orange blade guard back into its original position, next to the blades, and center the sliding table.
8. Align the scoring blade set to the main blade.

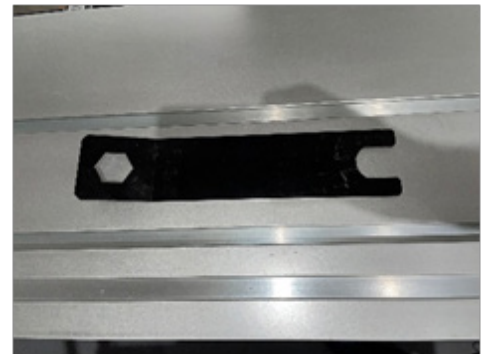

4.15 Rip Cutting

The panel saw has the capability of rip cutting full size panel panels, the sliding table removes the burden of sliding a large and heavy panel over a stationary table surface.

The saw also with the capability of rip cutting smaller boards which is using the machine as a traditional table saw. Smaller, lighter boards are easier to slide across the stationary cast iron table surface to the right of the saw blade.

Rip Cutting with The Sliding Table:

1. Install the crosscut fence in the center stud hole.
Note: Drop the crosscut fence into the center stud hole and align it to the 90° stop. Check to make sure the fence is at 90° and adjust it.
2. Slide the protection block to the edge of the slider, then tighten the lock knob. Scale will not be accurate if the protection block is cut.
3. Set a lip stop to the desired width-of-cut.
4. Position the blade guard to the correct height for your workpiece.
5. Load the workpiece onto the table saw.
6. Take all the necessary safety precautions, then perform the cutting operation.

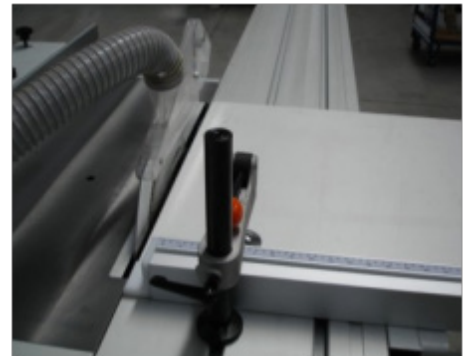
**4.16 Lubrication**

Lubricate the areas indicated below every 6-12 months, depending on frequency of use.

1. Blade angling trunnion.
2. Sliding table track.
3. Scoring blade threaded rod.
4. Blade height linkage.
5. Blade height bearing.
6. Blade tilt threaded rod.
7. Blade height slide.



4.17 Replace Belts

To change V-belt for the main motor.

1. Disconnect the saw from the power source.
2. Move the blade tilt to 0° (blade 90° to table) and raise the main blade and scoring blade set up.
3. Open the motor cabinet door.
4. Loosen the hex head bolt A and B, and tight the hex head bolt B.
5. Remove the V-belt and replace them with new belts. Then loosen the hex head bolt B. (Pivot the motor down)
6. Tighten the hex head bolt A and B until the belts deflect between a 1/4" and a 1/2" when pressed firmly in the center of each V-belt.
7. Close and secure the motor cabinet door.

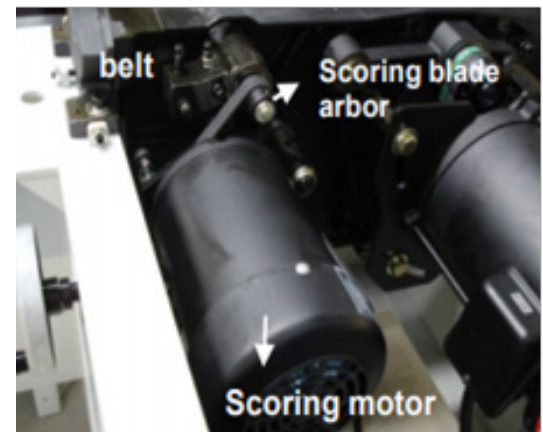

To change flat belt for the scoring motor (Option):

1. Disconnect the saw from the power source.
2. Move the blade tilt to 0° (blade 90° to table) and raise the main blade and scoring blade set up.
3. Open the motor cabinet door.
4. Push the scoring blade motor and remove the flat belt.
5. Place the flat belt on the scoring blade arbor, lift the scoring motor and slide the flat belt over the scoring motor pulley.
6. Close and secure the motor cabinet door.

5 Maintenance

Make sure that your machine is disconnected from the power source before performing any maintenance, cleaning, lubrication, adjustments or changing accessories, blades, etc.

5.1 General Cleanliness

- Please DO NOT attempt to remove the wood chips while the saw is turned on.
- Clean all saw dust and periodically remove lumps of wood even if you use a dust collector, there may be parts that remain in the machine.
- After each work cycle, clean all parts, vacuum the chips, dust and any resin.
- Periodically use compressed air to blow electrical contacts and moving mechanical parts due to the accumulation of dust in the saw.
- Use a vacuum cleaner to clean inside the motor case.
- Apply oil (SAE10) or equivalent lubricant to the moving parts only after equipment has been completely cleaned.
- Weekly clean and lubricate the moving parts of the machine with a thin film of oil and grease.
- Protect all belts and pulleys from contamination with oil.
- Always use a dust collector with a minimum of 2 HP.

5.2 Electrical Maintenance

- Apply a multi-purpose or electrical cleaner to the electrical components periodically (on average every 3 months).
- We recommend that you use a surge protection circuit breaker, installed in the power supply workshop to prevent short circuits of any electrical component of the machine.

5.3 Mechanical Maintenance

- Maintain tension on the belts, if you notice any changes in the way the saw blade spins.
- If you need to replace the lubricating oil in the tank, use the SAE-10.
- Lubricate by pumping handle on oil tank once before major work.
- Parts used are durable, they should not break easily and should last for several years.
- Check for bolts or nuts that need to be retightened.
- Always replace broken parts with OEM spare parts.
- Only use blades that are sharpened correctly, according to EN 847 1: 2005 used. Do not use blades that have a maximum speed less than, the maximum speed of the saw's motors. Always leave a space between the riving knife and the saw blade of at minimum 3 mm (1/8 in) and at most 8 mm (3/8 in).

5.4 Saw Blade Lubrication Chart

| | | Machine | | Saw | | | | | |
|------------------------------|--|----------------------|--------------|---------------------|-------------------------|--------------------------------------|-------------|-------------|--|
| | | Model | | BMS.3200.IR | | | | | |
| Table of grease and lubrican | | Where to apply? | | Sliding table track | Height adjustment guide | Threaded rod | Handle base | Tilt system | |
| | | Grease/Oil suggested | MOBIL | - | MOBILUX EP2 | MOBILGREASE HP 222 MOBILGREASE MP | | | |
| | | | ESSO | - | LITHTAN EP2 | BEACON 2 | | | |
| | | | SHELL | - | EPRO | ALVANIA R2 | | | |
| | | | CASTROL | - | SPHEEROL EP2 | LM 2 | | | |
| | | | BARDAHL | - | - | MAX LUB APG2 | | | |
| | | | IPIRANGA | - | - | IPIFLEX 2 | | | |
| | | | PETROBRAS | - | - | GMA-2 | | | |
| | | | TEXACO | - | - | MARFAK MP2 | | | |
| | | | CARBOGRAFITE | - | Silicone | - | | | |
| Lubrication period | | 40 hours | | | | | | | |

5.5 Part Replacement and Disposal

- If replacement should become necessary, only OEM parts should be used to ensure the same efficiency. The parts should be discarded according to the laws of each country. The substitutions of parts require training and technical skills; for this reason, the following instructions should be followed by qualified personnel to prevent damage to the machine and risks to the safety of people.
- CAUTION: In the event of mechanical or functional defects in the machine, including tools, please contact your service representative for service. Any repairs must be made only when the machine is disconnected from any power supply.

6 Troubleshooting Guide

- The necessary interventions should be made by our technical specialists. For any maintenance or repairs, please turn off the machine, remove the machine from the power supply and wait until the blade stop completely and then proceed with the service.
- For any problem, information or abnormality with the machine, contact the distributor in your area or directly with our service center after sale of MAKSIWA INTERNATIONAL INC., through 844-319-6594

| Problem | Possible Cause | Solution |
|--|---|---|
| Saw stopped, no longer spins. | Excessive load on the motor. | Wait for motor to cool off, then flip off/on circuit breaker. |
| | Saw has fallen off of shaft. | Check washer and lock nut. |
| | Triggered circuit breaker. | Flip circuit breaker off/on. |
| | Damaged or loose wire. | Locate and replace wire. |
| Does not make exact cuts at 45° or 90°. | Misaligned blade stopper. | Adjust the stop. |
| | Wood is warped. | Replace wood for a good piece. |
| | Loose blade nut/ Warped saw blade. | Tighten nut or replace Blade. |
| | Riving knife not aligned. | Riving knife with the saw blade. |
| Saw makes unsatisfactory cuts. | Worn Blade. | Sharpen or replace blade. |
| | Mounted in the wrong direction. | Flip the blade. |
| | Glue on the blade. | Remove and clean blade. |
| | Worn blade for the material being cut. | Use correct blade. |
| | Glue on the table. | Clean the table. |
| Blade does not keep constant speed. | Incorrect wire gauge/size. | Use correct gauge/size wire. |
| | Low voltage. | Call electric service provider. |
| | Motor wiring is setup is incorrect. | Check and adjust wiring in motor. |
| Saw blade vibrates | Machine is not level. | Put the machine at level. |
| | Blade is damage. | Replace blades. |
| | Damage belt. | Replace belt. |
| | Pulled is tilted. | Replace pulley. |
| | Montagem imprópria do motor. | Verifique e ajuste o motor. |
| | Motor was assembled in the wrong position | Verify and adjust the motor. |
| | Hight guide is loose. | Tighten or adjust guide. |
| Wood kicks back when it comes in contact with the blade. | Aluminum guide is misaligned. | Align the guide. |
| | Riving knife misaligned. | Align the riving knife. |
| | Cut was made without guide support. | Install and use the guide. |
| | Worn blade. | Replace the blade. |
| | Piece was not held correctly. | Hold piece all the way through. |
| Blade has no height adjustment and slope. | The elevation system is too tight. | Adjust the elevation system. |
| | Dust and chips of wood are in the elevation system. | Clean and lube the components. |

7 Exploded View

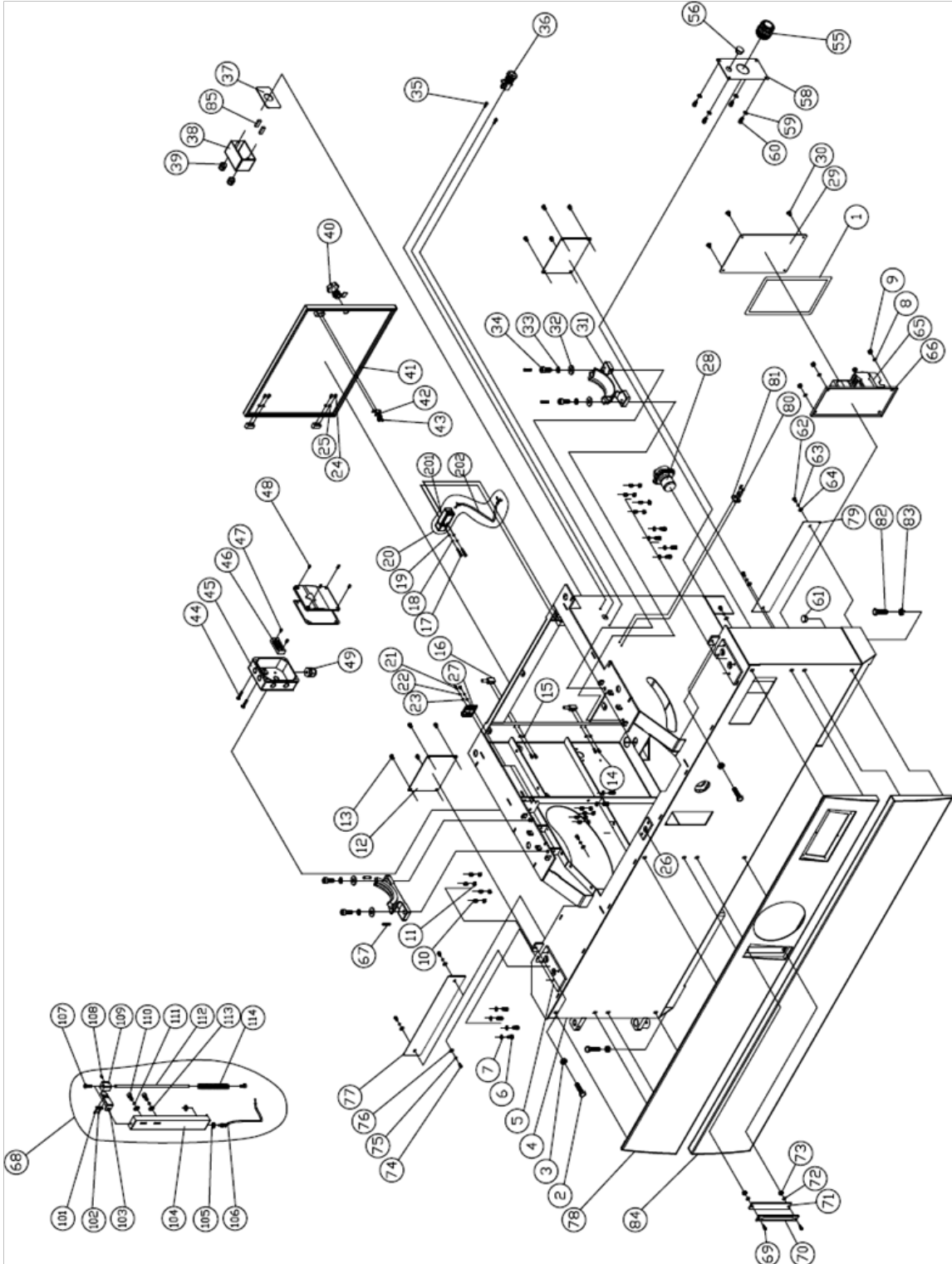

| Item | Part N° | Parts Name | Size | Qty | Note |
|------|-----------|------------------------|----------------|-----|------|
| 1 | 150527 | Pad | 2x300x7.5(M/M) | 4 | |
| 2 | SH100800 | Hex Head Bolt | M10*40 | 2 | |
| 3 | NH101700 | Hex Nut | M10 | 2 | |
| 4 | 206477 | Machine frame | | 1 | T9 |
| 5 | 205200-37 | Plate | | 2 | R |
| 6 | SR069300 | Cap Screw | M6*12 | 10 | |
| 7 | WS060000 | Lock Washer | M6 | 10 | |
| 8 | WF061310 | Washer | M6x13 | 4 | |
| 9 | NF061000 | Hex Flange Nut | M6 | 4 | |
| 10 | SS060400 | Set Screw | M6*20 | 12 | |
| 11 | NH061000 | Hex Nut | M6 | 12 | |
| 12 | 207128 | Plate | | 3 | T9 |
| 13 | SJ069300 | Button Head Screw | M6*12 | 12 | |
| 14 | SR059300 | Cap Screw | M5*12 | 4 | |
| 15 | WS050000 | Lock Washer | M5 | 4 | |
| 16 | 203412 | Block | | 2 | |
| 17 | SR040600 | Cap Screw | M4*30 | 2 | |
| 18 | WS040000 | Lock Washer | M4 | 2 | |
| 19 | WF040808 | Washer | M4*8 | 2 | |
| 20 | AB136458 | Door Safety Switch ASM | | 1 | |
| 21 | SR069300 | Cap Screw | M6*12 | 2 | |
| 22 | WS060000 | Lock Washer | M6 | 2 | |
| 23 | WF061310 | Washer | M6x13 | 2 | |
| 24 | SR059200 | Cap Screw | M5*8 | 4 | |
| 25 | WS050000 | Lock Washer | M5 | 4 | |
| 26 | 205200-28 | Plate | | 1 | T9 |
| 27 | 206342 | Plate | | 1 | |
| 28 | 994809 | Power Switch | ZH-HD-2 | 1 | |
| 29 | 201893 | Plate | | 1 | T9 |
| 30 | SJ060200 | Button Head Screw | M6x10 | 4 | |
| 31 | 207540 | Base | | 2 | X2 |
| 32 | WF102030 | Washer | M10*20 | 4 | |
| 33 | WS100000 | Lock Washer | M10 | 4 | |
| 34 | SR100700 | Cap Screw | M10*35 | 4 | |
| 35 | ST050400 | Tap Screw | M5*20 | 2 | |
| 36 | 994808 | Emergency Stop Button | R2PNR4-1B-R | 1 | |

| Item | Part N° | Parts Name | Size | Qty | Note |
|------|-----------|-------------------|-----------|-----|------|
| 37 | 150956 | Pad | | 1 | |
| 38 | 605408 | Switch Box | | 1 | |
| 39 | 998621 | Strain Relief | | 2 | |
| 40 | 203430 | Lock | | 1 | |
| 41 | 205259 | Door | | 1 | R |
| 42 | WS040000 | Lock Washer | M4 | 2 | |
| 43 | SPO40400 | Pan Head Screw | M4*20 | 2 | |
| 44 | SJ060400 | Button Head Screw | M6*20 | 2 | |
| 45 | 201105 | Power Box | CE | 1 | CE |
| | 201105A | Power Box | | 1 | CSA |
| 46 | 994805 | Terminal | PB2504 4P | 0 | CE |
| | 994805 | Terminal | PB2504 4P | 1 | CSA |
| 47 | SPO59200 | Pan Head Screw | M5*8 | 2 | |
| 48 | SJ059300 | Button Head Screw | M5*12 | 4 | |
| 49 | 709421 | Strain Relief | PG20 | 2 | |
| 55 | 207318 | Strain Relief | MGB40-25B | 1 | |
| 56 | 201458 | Hole Plugs | HP-22 | 1 | |
| 58 | 207080 | Plate | | 1 | |
| 59 | WS060000 | Lock Washer | M6 | 4 | |
| 60 | SR069300 | Cap Screw | M6*12 | 4 | |
| 61 | 201458 | Hole Plugs | HP-22 | 1 | |
| 62 | SJ069300 | Button Head Screw | M6*12 | 4 | |
| 63 | WS060000 | Lock Washer | M6 | 4 | |
| 64 | WF061310 | Washer | M6*13 | 4 | |
| 65 | 200867 | Electric. Panel | 400V 3~ | 1 | |
| 66 | 200867A-1 | Plate | | 1 | |
| 67 | PS062500 | Spring Pin | 6*25 | 4 | |
| 68 | AB207399 | Steel Wire ASM | | 1 | |
| 69 | SPO40400 | Pan Head Screw/W | M4x20 | 2 | |
| 70 | LM001076 | Tilt Scale | | 1 | |
| 71 | 201785 | Plate | | 1 | |
| 72 | WF040808 | Washer | M4*8 | 2 | |
| 73 | NF040700 | Hex Nut | M4 | 2 | |
| 74 | SR069300 | Cap Screw | M6*12 | 12 | |
| 75 | WS060000 | Lock Washer | M6 | 12 | |
| 76 | WF061310 | Washer | M6*13 | 12 | |
| 77 | 207309-33 | Plate | | 1 | T9 |

| Item | Part N° | Parts Name | Size | Qty | Note |
|------|-----------|-----------------|---------|-----|------|
| 78 | 206580 | Front Cover | | 1 | R |
| 79 | 207299-32 | Plate | | 1 | T9 |
| 80 | ST049300 | Tap Screw | | 2 | |
| 81 | 170736 | Hanger | | 1 | |
| 82 | SH161000 | Hex Head Bolt | M16*50 | 4 | |
| 83 | NH162400 | Hex Nut | M16 | 4 | |
| 84 | 206478 | Front Cover | | 1 | T9 |
| 85 | 136019 | Cord Connector | 224-201 | 2 | |
| 89 | WF061310 | Washer | M6*13 | 8 | |
| 90 | 206367-33 | Cap Screw | | 1 | |
| 91 | 206368 | Front Cover | | 1 | |
| 92 | 206367-32 | Cap Screw | | 1 | |
| 93 | ST049300 | Tap Screw | | 4 | |
| 94 | 170736 | Hanger | | 2 | |
| 95 | SP059400 | Pan Head Screw | M5x16 | 2 | |
| 96 | SH120800 | Hex Head Bolt | M12*40 | 4 | |
| 97 | NH121900 | Hex Nut | M12 | 4 | |
| 101 | WF051210 | Washer | M5x12 | 2 | |
| 102 | SP050200 | Pan Head Screw | M5x10 | 2 | |
| 103 | 200840 | Pointer | | 1 | |
| 104 | 200841 | Fix Plate | | 1 | |
| 105 | WF061310 | Washer | M6x13 | 2 | |
| 106 | 207399 | Steel Wire | | 1 | |
| 107 | SR050200 | Cap Screw | M5x10 | 2 | |
| 108 | SS050200 | Setscrew | M5x10 | 1 | |
| 109 | 200843 | Indicator Block | | 1 | |
| 110 | SR069300 | Cap Screw | M6x12 | 2 | |
| 111 | WS060000 | Lock Washer | M6 | 2 | |
| 112 | 200842 | Shaft | | 1 | |
| 113 | WF061310 | Washer | M6x13 | 2 | |
| 114 | 200993 | Spring | | 1 | |

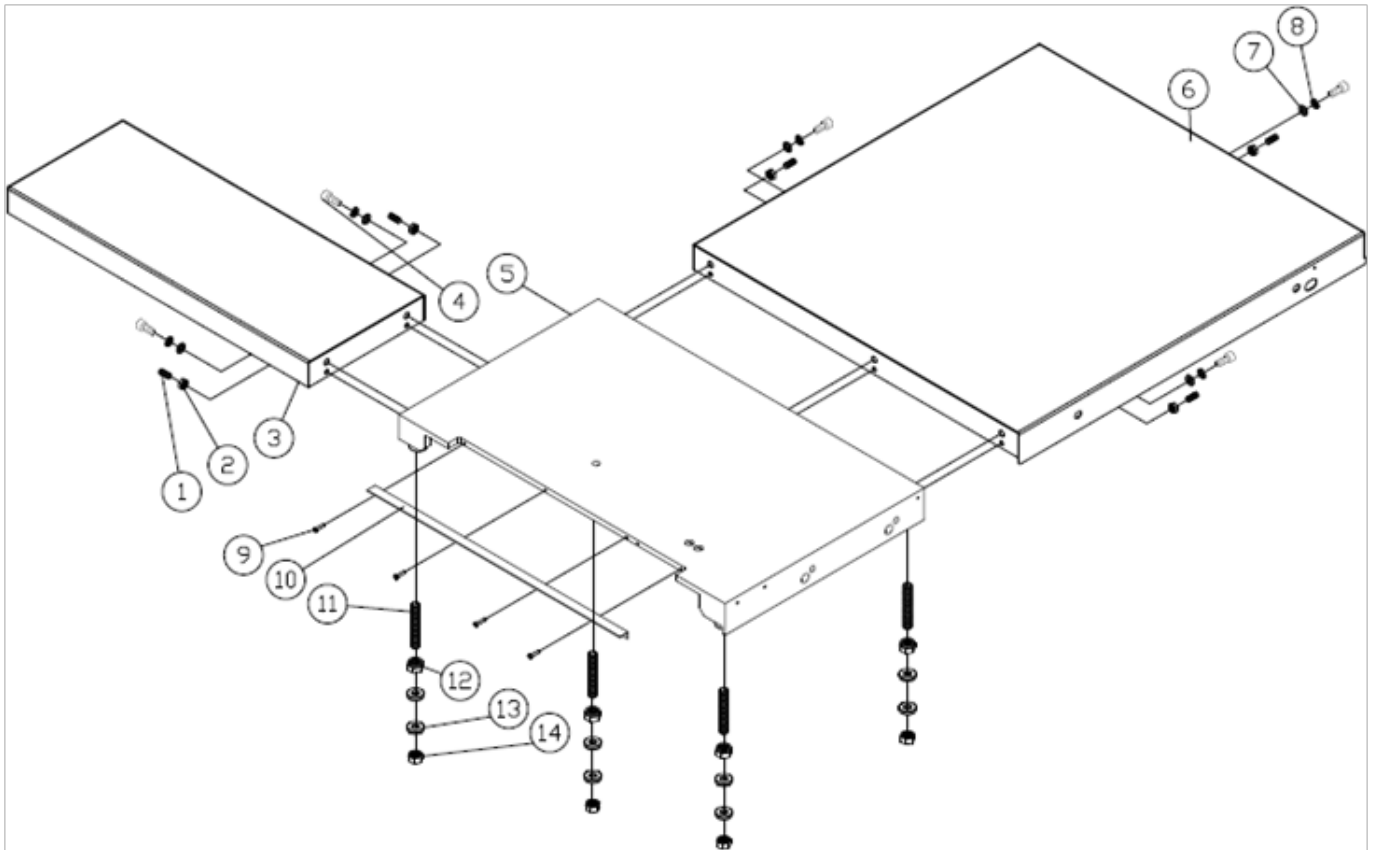

| Item | Part N° | Parts Name | Size | Qty | Note |
|------|----------|-------------------|-----------------------|-----|-------|
| 1 | SS100400 | Set Screw | M10*20 | 5 | H |
| 2 | NH101700 | Hex Nut | M10 | 5 | H |
| 3 | 207077 | Left Ext. Plate | (standard) | 1 | R |
| | 207151 | Left Ext. Plate | (optional) | 1 | R / S |
| 4 | SR100500 | Cap Screw | M10*25 | 5 | H |
| 5 | 206332 | Table | | 1 | R |
| 6 | 207078 | Ext. Plate | (standard) | 1 | R |
| | 207079 | Ext. Plate | (optional) | 1 | R / S |
| 7 | WF102030 | Washer | M10* \varnothing 20 | 5 | H |
| 8 | WS100000 | Lock Washer | M10 | 5 | H |
| 9 | SJ069300 | Button Head Screw | M6*12 | 4 | |
| 10 | 206354 | Table Insert | | 1 | |
| 11 | SS162000 | Set Screw | M16*100 | 4 | |
| 12 | NL162400 | Lock Nut | M16 | 4 | |
| 13 | 205016 | Washer | | 8 | |
| 14 | NH162400 | Hex Nut | M16 | 4 | |

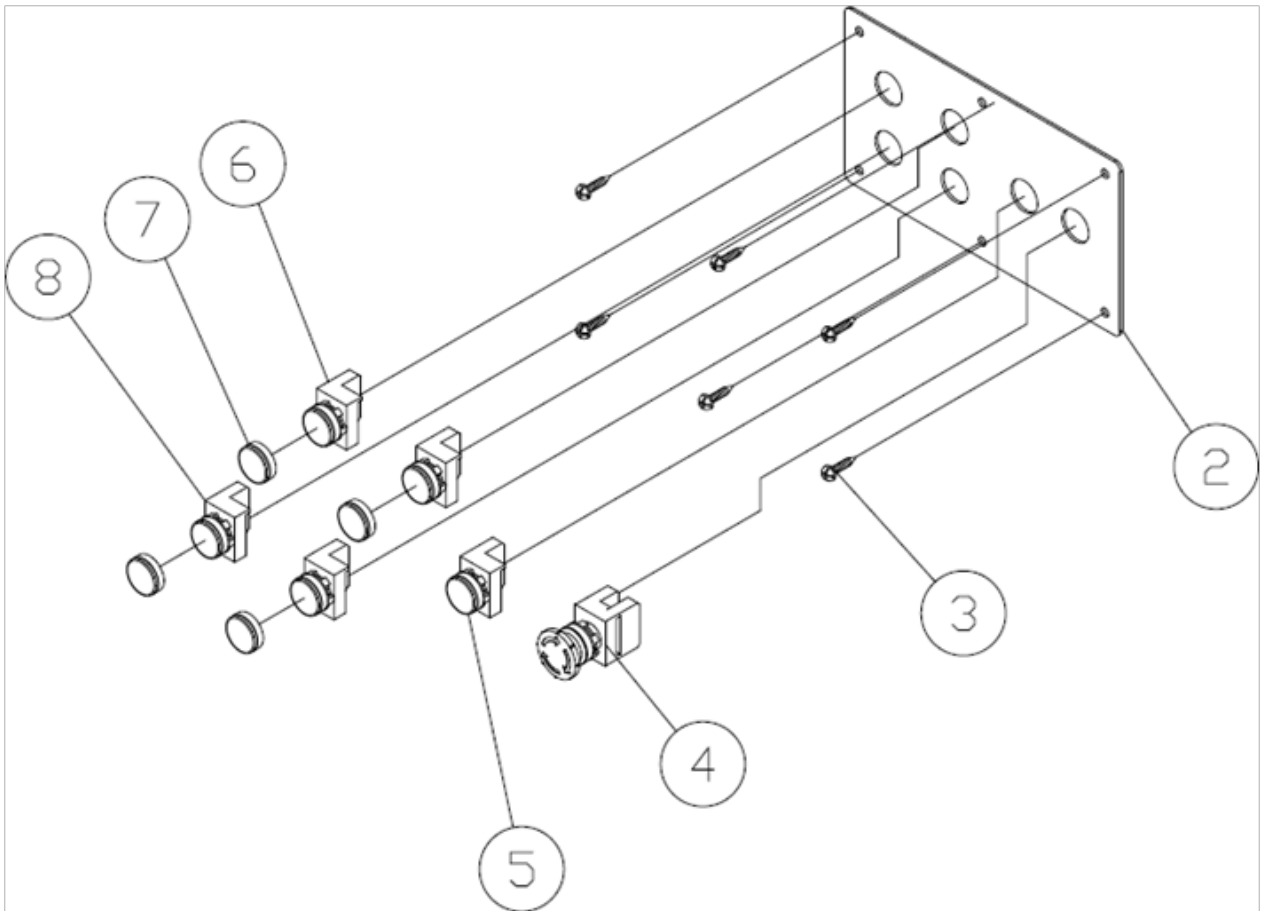

| Item | Part N° | Parts Name | Size | Qty | Note |
|------|----------|-----------------------|---------------|-----|------|
| 2 | 206407 | Panel | | 1 | |
| 3 | SJ050200 | Button Head Screw | M5*10 | 6 | |
| 4 | 994808 | Emergency Stop Button | | 1 | |
| 5 | 996002 | Pilot Lamp | YK.24V 22 (W) | 1 | |
| 6 | 994855 | Switch Button-ON | R2 PNF-1A-G | 2 | |
| 7 | 994855A | Dust Cove | R2 PRCF | 4 | |
| 8 | 994856 | Switch Button-OFF | R2 PNF-1B-R | 2 | |

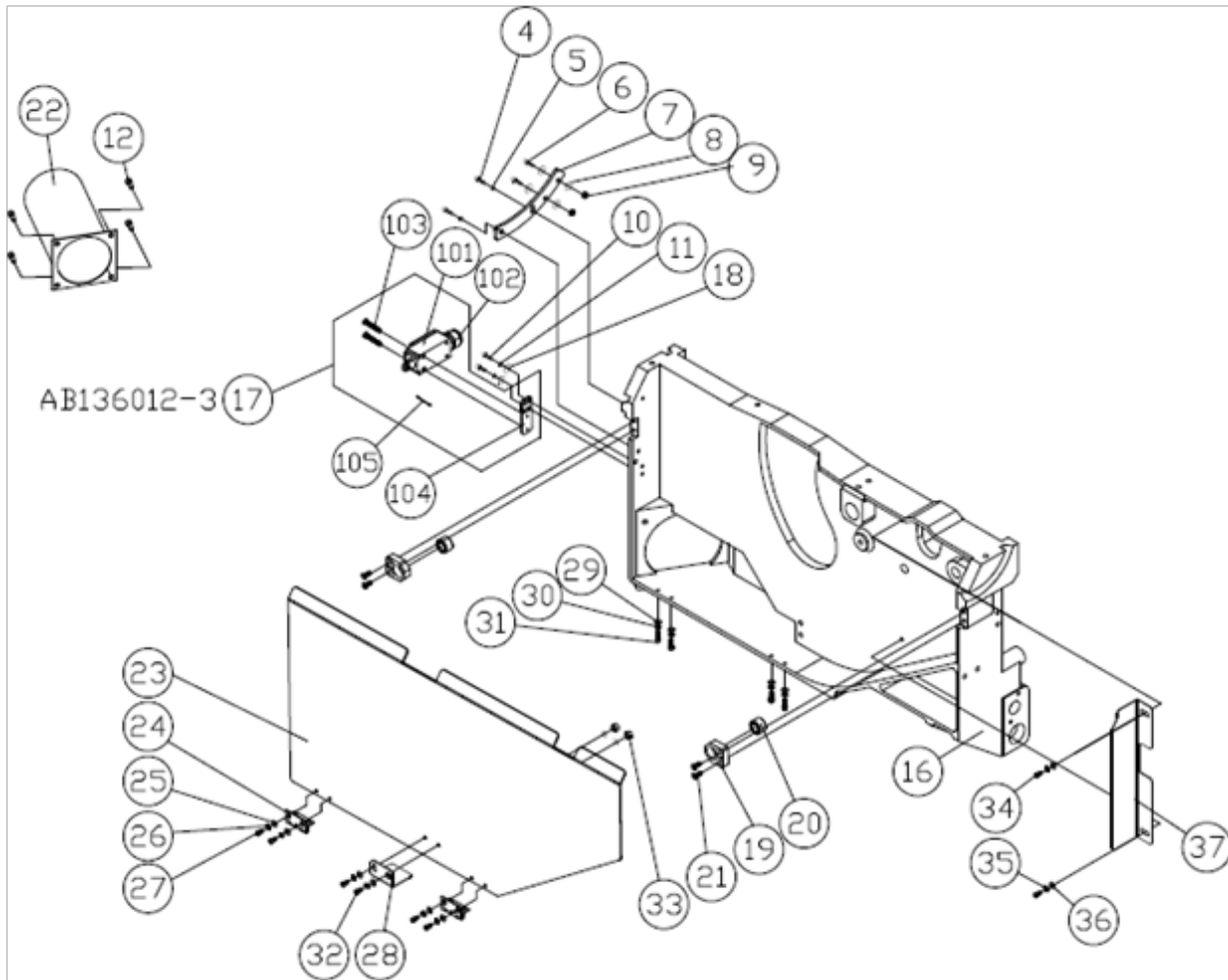

| Item | Part N° | Parts Name | Size | Qty | Note |
|------|------------|-----------------------------|-------|-----|----------|
| 4 | SR069300 | Cap Screw | M6*12 | 2 | |
| 5 | WS060000 | Lock Washer | M6 | 2 | |
| 6 | SR059400 | Cap Screw | M5*16 | 2 | |
| 7 | 206337 | Fix Plate | | 1 | |
| 8 | WF051010 | Washer | M5*10 | 4 | |
| 9 | NL050800 | Lock Nut | M5 | 2 | |
| 10 | SR059300 | Cap Screw | M5*12 | 2 | |
| 11 | WS050000 | Lock Washer | M5 | 2 | |
| 12 | SF089300 | Hex Head Bolt (+)/W | M8x12 | 4 | |
| 16 | 206301 | Channel Base | | 1 | YF206301 |
| 17 | AB136012-3 | Door Safety Switch Assembly | | 1 | A |
| 18 | WF051010 | Washer | M5*10 | 2 | |
| 19 | 206359 | Plate | | 2 | |

| Item | Part N° | Parts Name | Size | Qty | Note |
|------|----------|-------------------------|-------|-----|------|
| 20 | 203249 | Magnetic Iron(assembly) | | 2 | A |
| | 203249-1 | Magnetic Iron | | 1 | |
| | 203249-3 | Screw | | 1 | |
| 21 | SM060400 | Sunk head Socket Screw | M6x20 | 4 | |
| 22 | 206118 | Dust Port | | 1 | |
| 23 | 206324 | Cover | | 1 | F1L |
| 24 | 207940 | Hinge | | 2 | |
| 25 | WF051010 | Washer | M5*10 | 8 | |
| 26 | WS050000 | Lock Washer | M5 | 6 | |
| 27 | SR059200 | Cap Screw | M5*8 | 4 | |
| 28 | 207152 | Plate | | 1 | |
| 29 | WF051010 | Washer | M5*10 | 4 | |
| 30 | WS050000 | Lock Washer | M5 | 4 | |
| 31 | SR050200 | Cap Screw | M5*10 | 4 | |
| 32 | SR059400 | Cap Screw | M5*16 | 2 | |
| 33 | NH050800 | Hex Nut | M5 | 2 | |
| 34 | SR060200 | Cap Screw | M6*10 | 2 | |
| 35 | WS060000 | Lock Washer | M6 | 2 | |
| 36 | WF061620 | Washer | M6*16 | 2 | |
| 37 | 206479 | Plate | | 1 | |

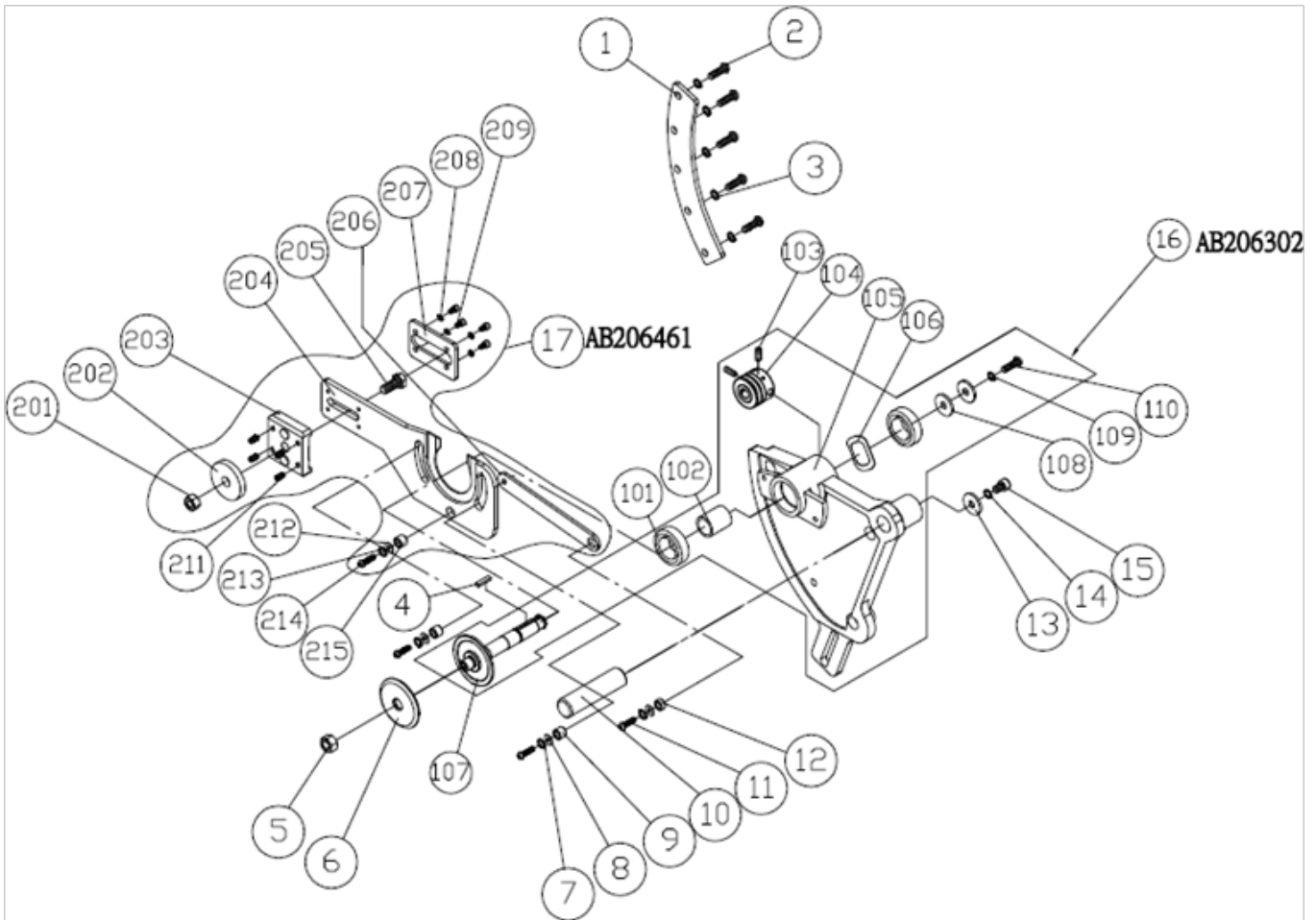

| Item | Part N° | Parts Name | Size | Qty | Note |
|------|----------|-------------------|---------|-----|------|
| 1 | 206304 | Gip Plate | | 1 | |
| 2 | SJ100500 | Button Head Screw | M10×25 | 5 | |
| 3 | WS100000 | Spring Washer | M10 | 5 | |
| 4 | KD050520 | Key | 5x5x20 | 1 | |
| 5 | 201822 | Nut | M16x2.0 | 1 | |
| 6 | 206350 | Arbor Flange | 25.4 | 1 | S |
| | 206380 | Arbor Flange | 30 | 1 | |
| 7 | WS080000 | Lock Washer | M8 | 3 | |
| 8 | WF083030 | Washer | M8×30 | 3 | |
| 9 | 200964 | Bushing | | 3 | |
| 10 | 201205 | Shaft | | 1 | |
| 11 | SJ080400 | Button Head Screw | M8×20 | 3 | |

| Item | Part N° | Parts Name | Size | Qty | Note |
|------|------------|-------------------------------|-----------------|-----|----------|
| 12 | 201346 | Bushing | | 1 | |
| 13 | WF083030 | Washer | M8×30 | 1 | |
| 14 | WS080000 | Lock Washer | M8 | 1 | |
| 15 | SR080400 | Cap Screw | M8×20 | 1 | |
| 16 | AB206302-4 | Main arbor (30 , Pulley 60HZ) | SS-D30P2 D305P2 | 1 | A |
| 17 | AB206461 | Fix Block ASM | | 1 | |
| 101 | BB620604 | Bearing | 6206LLB | 2 | |
| 102 | 206311 | Spacer | | 1 | |
| 103 | SS050200 | Setscrew | M5×10 | 3 | |
| 104 | 208041 | Pulley | | 1 | |
| 105 | 206302 | Rotate Plate | | 1 | YF206302 |
| 106 | WW476004 | Wave Washer | 47×60 | 2 | |
| 107 | 206357 | Main Arbor | 30 | 1 | |
| | 206310 | Main Arbor | 25.4 | 1 | S |
| 108 | WF083030 | Washer | M8×30 | 2 | |
| 109 | WS080000 | Lock Washer | M8 | 1 | |
| 110 | SJ080400 | Button Head Screw | M8×20 | 1 | |
| 201 | NH101704 | Hex Nut | M10 | 1 | |
| 202 | WF104040 | Washer | M10×40 | 1 | |
| 203 | 206461 | Fix Block | | 1 | |
| 204 | 206309 | Locate Plate | | 1 | |
| 205 | SH100600 | Hex Head Bolt | M10×30 | 1 | |
| 206 | 206360 | Link Plate | | 1 | |
| 207 | 201881 | plate | | 1 | |
| 208 | WS050000 | Lock Washer | M5 | 4 | |
| 209 | SJ050200 | Button Head Screw | M5×10 | 4 | |
| 211 | SS050200 | Setscrew | M5×10 | 4 | |
| 212 | WF083030 | Washer | M8×30 | 1 | |
| 213 | WS080000 | Lock Washer | M8 | 1 | |
| 214 | SJ080400 | Button Head Screw | M8×20 | 1 | |
| 215 | 200964 | Bushing | | 1 | |

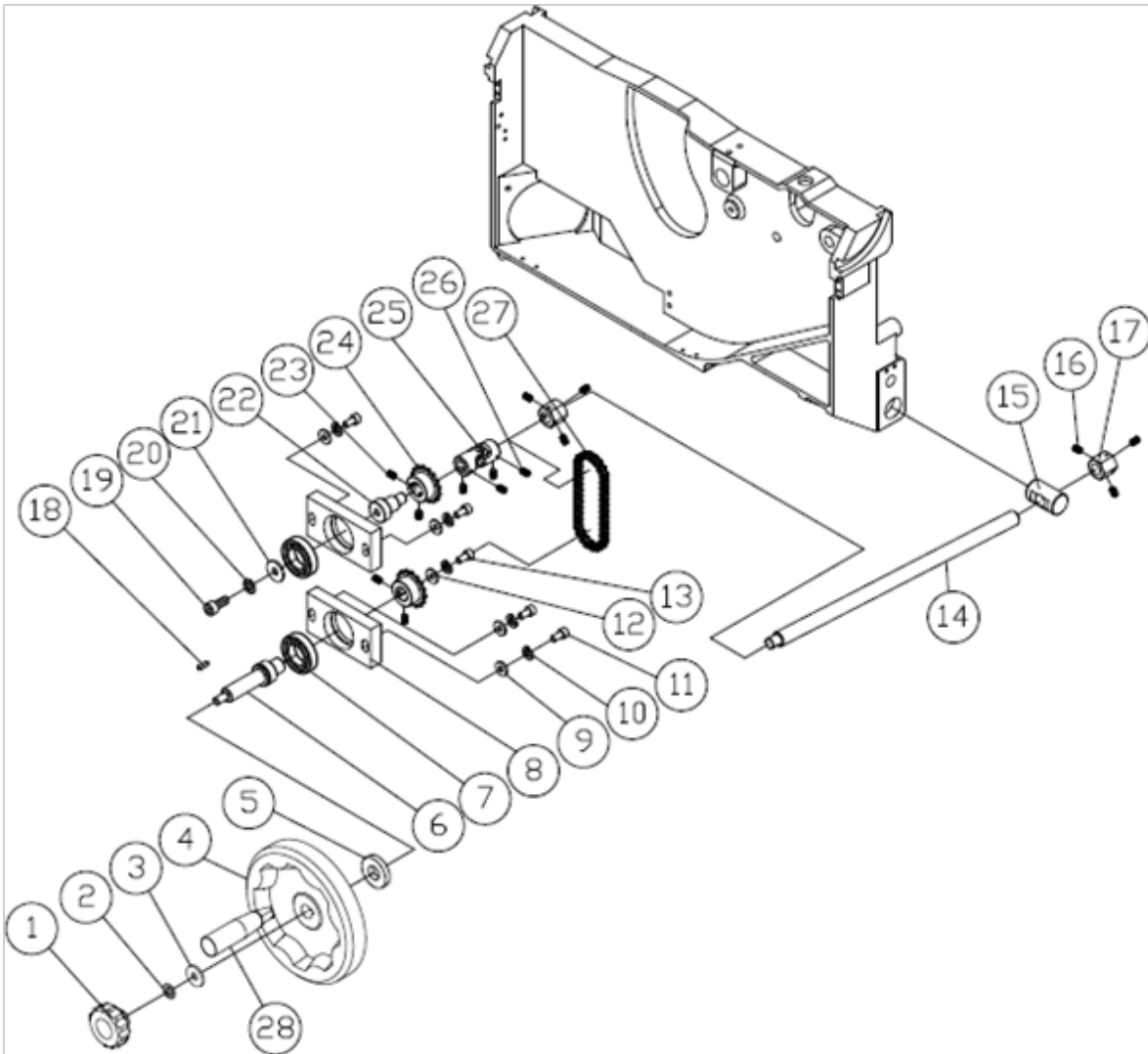

| Item | Part N° | Parts Name | Size | Qty | Note |
|------|-----------|--------------|--------|-----|------|
| 1 | 100203 | Lock Knob | M10 | 1 | |
| 2 | 204263 | Washer | 10×20 | 1 | |
| 3 | WF102730 | Washer | M10×27 | 1 | |
| 4 | 206434A | hand wheel | 8" | 1 | |
| 5 | 201567 | Washer | | 1 | |
| 6 | 206444 | Shaft | | 1 | |
| 7 | BB600602A | Bearing | 6006ZZ | 2 | |
| 8 | 206409 | Locate Plate | | 2 | |
| 9 | WF081818 | Lock Washer | M8x18 | 4 | |
| 10 | WS080000 | Lock Washer | M8 | 5 | |
| 11 | SR080700 | Cap Screw | M8×35 | 4 | |
| 12 | WF083030 | Lock Washer | M8x30 | 1 | |

| Item | Part N° | Parts Name | Size | Qty | Note |
|-------------|----------------|-------------------|-------------|------------|-------------|
| 13 | SR080400 | Cap Screw | M8×20 | 1 | |
| 14 | 207176 | Screw | | 1 | |
| 15 | 206328 | Shaft | | 1 | |
| 16 | SS069100 | Set Screw | M6×6 | 6 | |
| 17 | 206379 | Set Nut | | 2 | |
| 18 | KS070720 | Key | 7x7x20 | 1 | |
| 19 | SR100400 | Cap Screw | M10*20 | 1 | |
| 20 | WS100000 | Lock Washer | M10 | 1 | |
| 21 | WF104030 | Washer | M10×40 | 1 | |
| 22 | 206410 | Shaft | | 1 | |
| 23 | SS060200 | Set Screw | M6×10 | 4 | |
| 24 | 207115 | Sprocket | | 2 | |
| 25 | 207461 | Free Joint | 14 | 1 | |
| 26 | SS069100 | Set Screw | M6×6 | 4 | |
| 27 | 206441 | Chain | | 1 | |
| 28 | 200866-1 | | | 1 | |

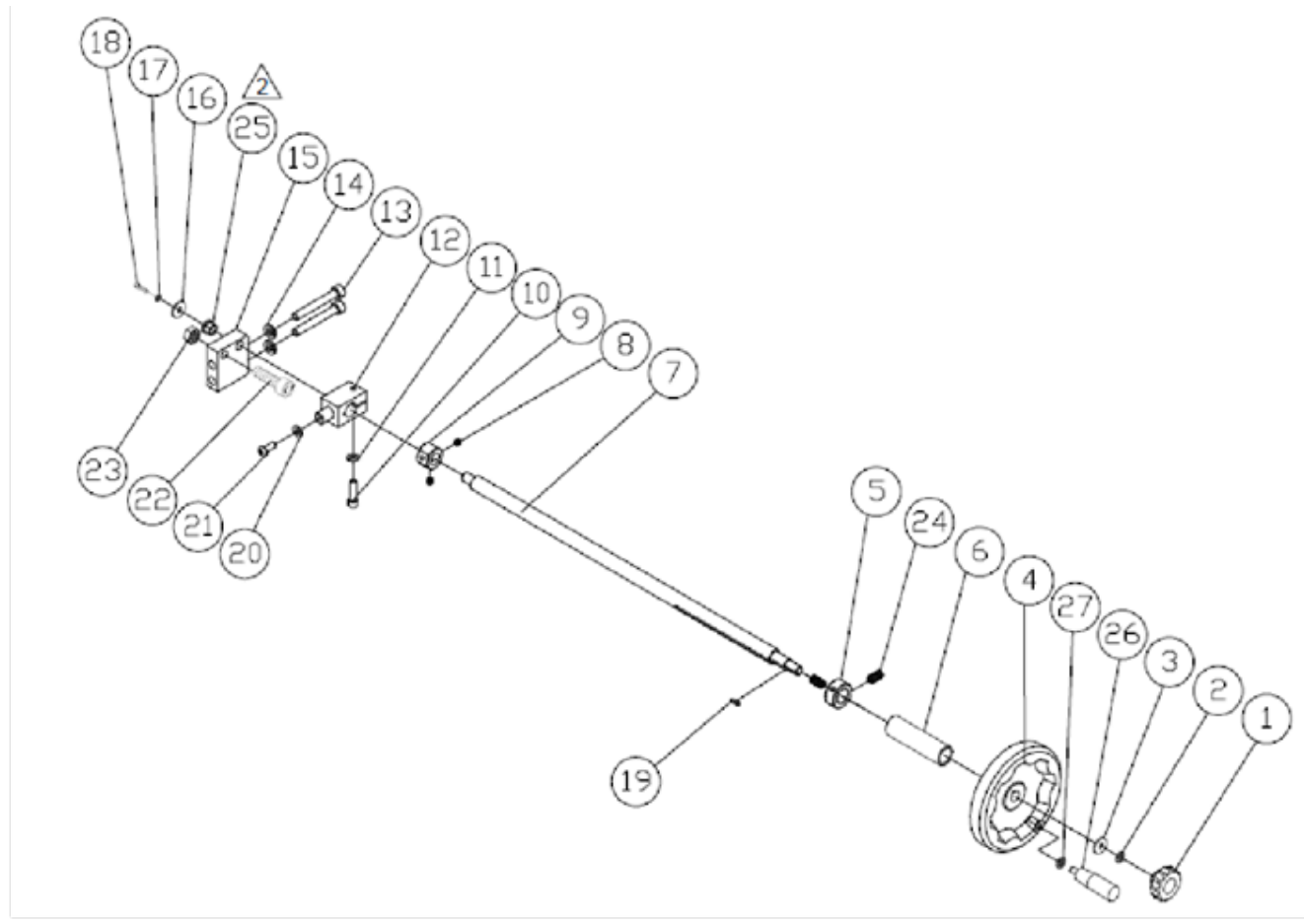

| Item | Part N° | Parts Name | Size | Qty | Note |
|------|----------|-------------|--------|-----|----------|
| 1 | 100203 | Lock Knob | M10 | 1 | |
| 2 | 204263 | Washer | 10×20 | 1 | |
| 3 | WF103030 | Washer | M10×30 | 1 | |
| 4 | 204289B | Hand Wheel | | 1 | standard |
| | 204176A | Hand Wheel | | 1 | S |
| 5 | 200855 | Bushing | | 1 | |
| 6 | 206385 | Sleeve | | 1 | |
| 7 | 206327 | Screw | | 1 | |
| 8 | SS069100 | Setscrew | M6×6 | 3 | |
| 9 | 206379 | Set Nut | | 1 | |
| 10 | SR060600 | Cap Screw | M6×30 | 1 | |
| 11 | WS060000 | Lock Washer | M6 | 2 | |
| 12 | 206326 | Hex Nut | | 1 | |
| 13 | SR081200 | Cap Screw | M8×60 | 2 | |

| Item | Part N° | Parts Name | Size | Qty | Note |
|------|----------|--------------|-------------|-----|----------|
| 14 | WS080000 | Lock Washer | M8 | 2 | |
| 15 | 206325 | Locate Block | | 1 | |
| 16 | WF061310 | Washer | M6×13 | 1 | |
| 17 | WS060000 | Lock Washer | M6 | 1 | |
| 18 | SR069300 | Cap Screw | M6×12 | 1 | |
| 19 | KS050520 | Key | 5*5*20 | 1 | |
| 20 | WF061620 | Washer | M6×16 | 1 | |
| 21 | SJ060200 | Cap Screw | M6×10 | 1 | |
| 22 | SS100700 | Setscrew | M10×35 | 1 | |
| 23 | NH101700 | Hex Nut | M10 | 1 | |
| 24 | SS080200 | Setscrew | M8x10 | 2 | |
| 25 | 017177 | | | 1 | |
| 26 | 206460 | Handle | M10 , 7" | 1 | standard |
| 27 | WF101608 | Washer | M10×16×t0.8 | 1 | |

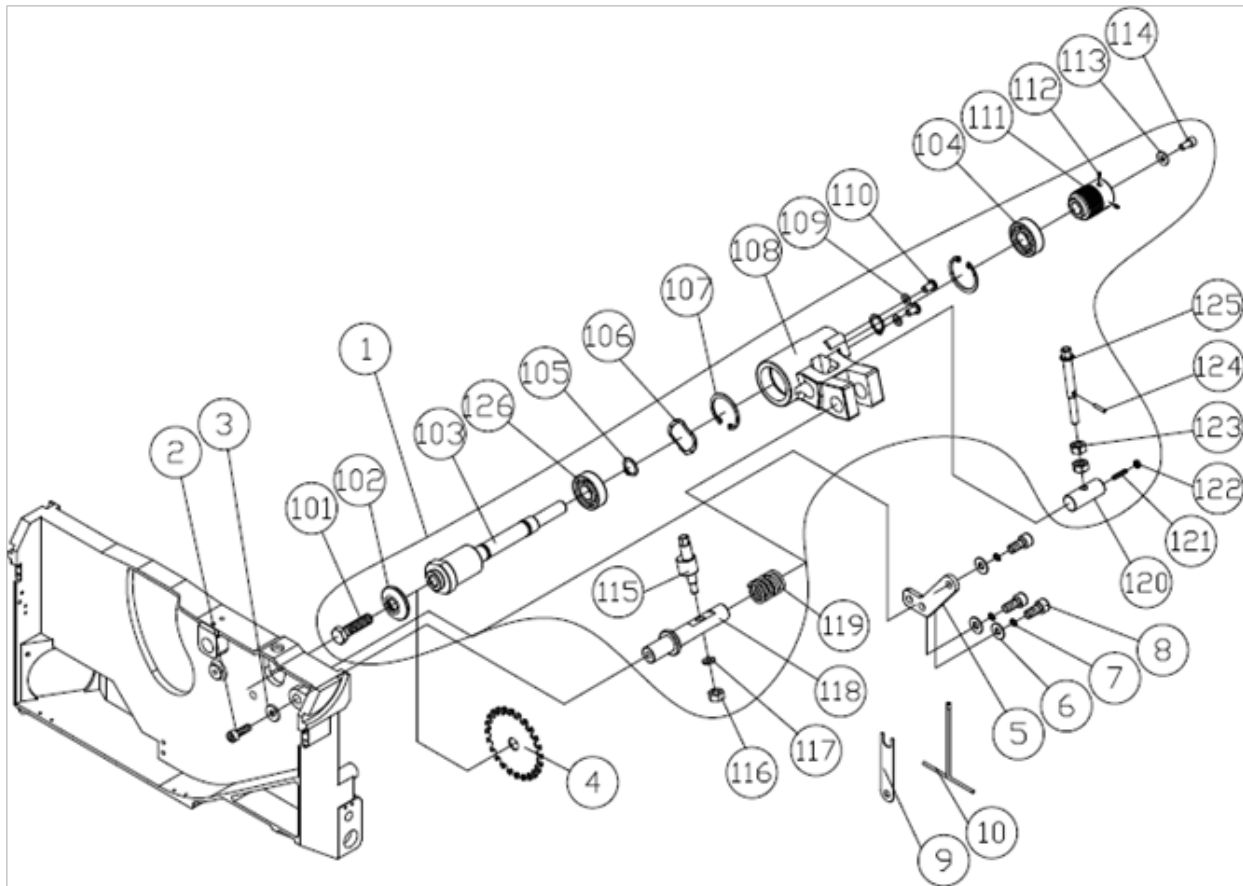

| Item | Part N° | Parts Name | Size | Qty | Note |
|------|------------|---------------------|---------|-----|------|
| 1 | AB206315-1 | Pulley ASM | | 1 | |
| 2 | SR080400 | Cap Screw | M8*20 | 1 | |
| 3 | WF083030 | Washer | M8*30 | 1 | |
| 4 | 200973 | Scoring Saw Blade | 20 | 1 | |
| 5 | 206365 | Fix Plate | | 1 | |
| 6 | WF061310 | Washer | M6x13 | 3 | |
| 7 | WS060000 | Lock Washer | M6 | 3 | |
| 8 | SR069400 | Cap Screw | M6*16 | 3 | |
| 9 | 206366 | Wrench | | 1 | |
| 10 | 206369 | Wrench | 8mm | 1 | |
| 101 | SH120440 | Hex Head Bolt | M12x20 | 1 | |
| 102 | 206320 | Flange | | 1 | |
| 103 | 206321 | Shaft | | 1 | |
| 104 | BB620204 | Ball Bearing | 6202LLB | 1 | |
| 105 | RS150000 | Int. Retaining Ring | S15 | 2 | |

| Item | Part N° | Parts Name | Size | Qty | Note |
|------|----------|---------------------|----------------------|-----|----------|
| 106 | WW263403 | Wave Washer | 26*34 t=0.3 (6202) | 2 | |
| 107 | RR350000 | Int. Retaining Ring | R35 | 2 | |
| 108 | 206303 | Shaft | | 1 | YF206303 |
| 109 | WF061310 | Washer | M6x13 | 2 | |
| 110 | SJ069400 | Button Head Screw | M6*16 | 2 | |
| 111 | 206315 | Pulley | | 1 | |
| 112 | SS069100 | Set Screw | M6×6 | 3 | |
| 113 | WF061620 | Washer | M6x16 | 1 | |
| 114 | SH069402 | Hex Head Bolt | M6×16(L.H) | 1 | |
| 115 | 206316 | Shaft | | 1 | |
| 116 | NL061000 | Lock Nut | M6 | 1 | |
| 117 | 206395 | Spring | 15*6.2*0.5t | 1 | |
| 118 | 206318 | Shaft | | 1 | |
| 119 | 206323 | Spring | | 1 | |
| 120 | 206319 | Shaft | | 1 | |
| 121 | 206386 | Set Screw | M6*25 | 1 | |
| 122 | NH061000 | Hex Nut | M6 | 1 | |
| 124 | PS031200 | Spring Pin | 3*12 | 1 | |
| 125 | 206317 | Screw | | 1 | |
| 126 | BB600304 | Ball Bearing | 6003LLB | 1 | |

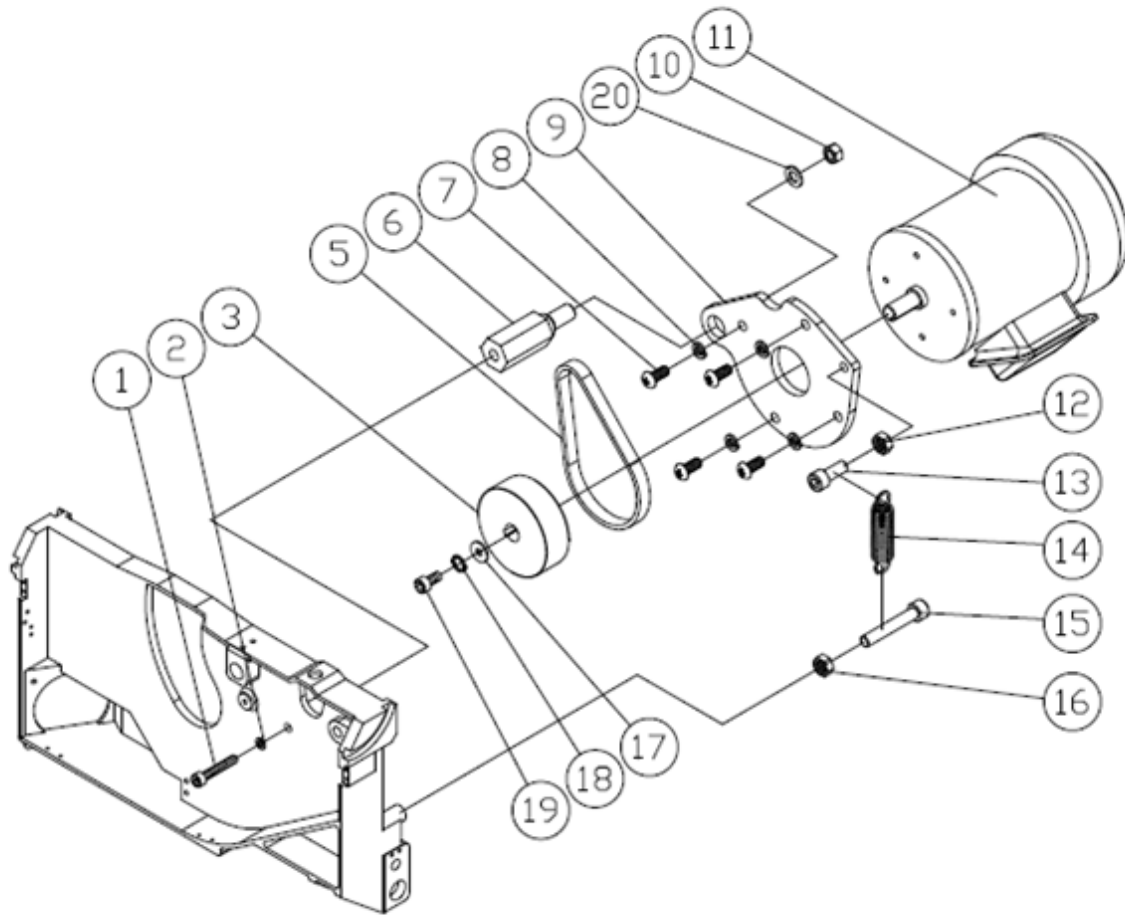

| Item | Part N° | Parts Name | Size | Qty | Note |
|------|----------|-------------------|--------------|-----|----------|
| 1 | SR122000 | Cap Screw | M12*100 | 1 | |
| 2 | WS120000 | Lock Washer | M12 | 1 | |
| 3 | 206314 | Pully | | 1 | 50Hz |
| | 206336 | Pully | | 1 | 60Hz |
| 5 | LJ014070 | Belt | 140J7 | 1 | 60Hz |
| | LJ015070 | Belt | 150J7 | 1 | 50Hz |
| 6 | 206313 | Shaft | | 1 | |
| 7 | SJ080400 | Button Head Screw | M8*20 | 4 | |
| 8 | WS080000 | Lock Washer | M8 | 4 | |
| 9 | 206331 | Plate | | 1 | |
| 10 | NL142200 | Lock Nut | M14 | 1 | |
| 11 | MH206301 | Scoring Motor | 0.75P (M20P) | 1 | optional |
| 12 | NH101700 | Hex Nut | M10 | 1 | |
| 13 | SR100400 | Cap Screw | M10*20 | 1 | |
| 14 | 201275 | Expansion Spring | | 1 | |

| Item | Part N° | Parts Name | Size | Qty | Note |
|------|----------|-------------|--------|-----|------|
| 15 | SR101000 | Cap Screw | M10*50 | 1 | |
| 16 | NH101700 | Hex Nut | M10 | 1 | |
| 17 | WF063030 | Washer | M6*30 | 1 | |
| 18 | WS060000 | Lock Washer | M6 | 1 | |
| 19 | SR069400 | Cap Screw | M6*16 | 1 | |
| 20 | WF143530 | Washer | M14*35 | 1 | |

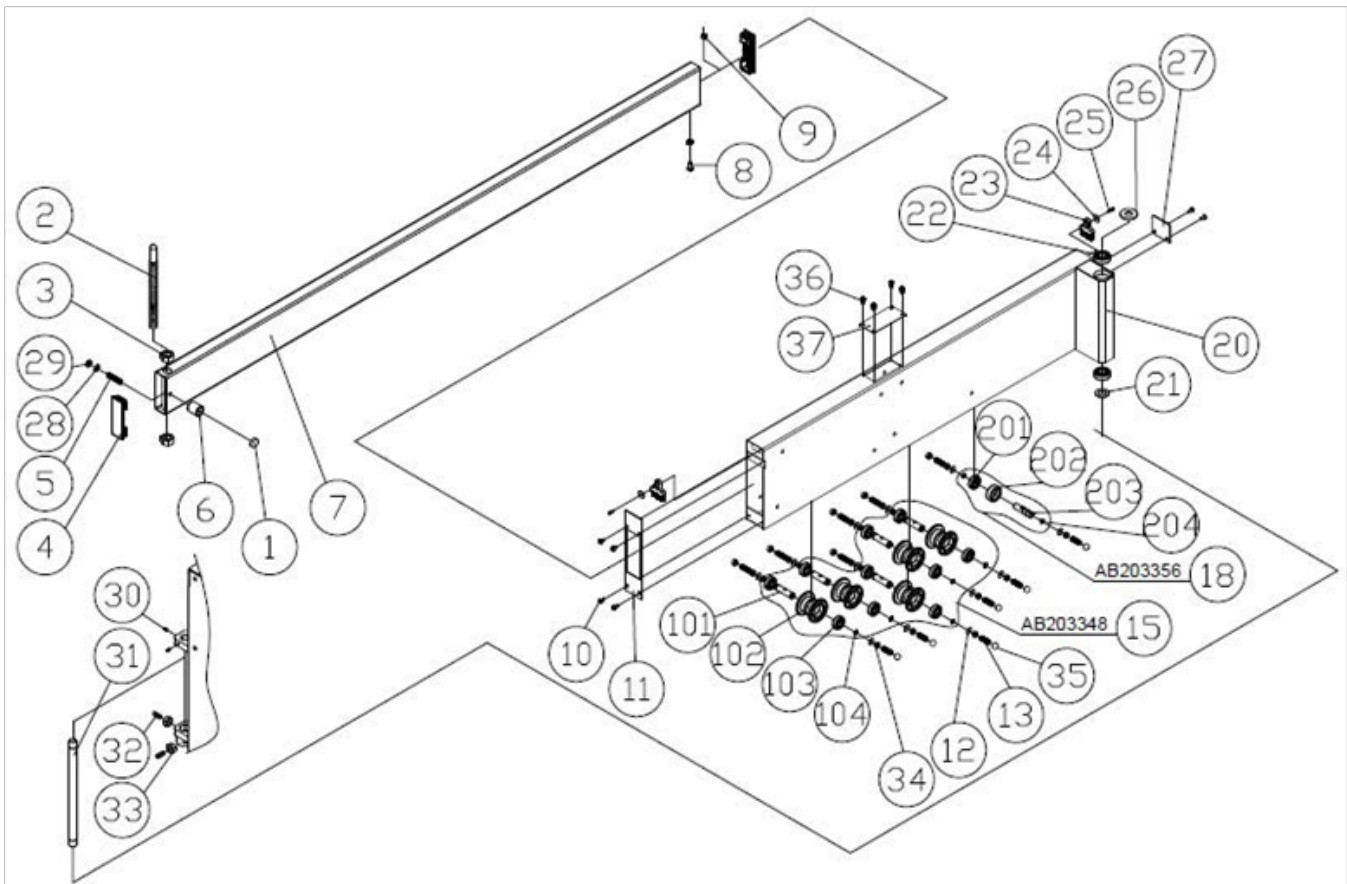

| Item | Part N° | Parts Name | Size | Qty | Note |
|------|----------|---------------|----------|-----|------|
| 1 | 200934-2 | Magnet | | 1 | |
| 2 | 203416 | Screw Threads | | 1 | S,E |
| | 205505A | Screw Threads | | 1 | S,D |
| 3 | NH203000 | Hex Nut | M20x2.5p | 2 | |
| 4 | 203470 | Plug | 40*120 | 2 | |
| 5 | SS080700 | Set Screw | M8*35 | 1 | |

| Item | Part N° | Parts Name | Size | Qty | Note |
|------|-----------|---------------------|----------|-----|------|
| 6 | 201146-1 | Magnetic Bracket | | 1 | |
| 7 | 207856 | Sliding Tube | | 1 | T |
| 8 | SH080400 | Hex Head Screw | M8*20 | 1 | |
| 9 | NH081300 | Hex Nut | M8 | 2 | |
| 10 | SJ060200 | Button Head Screw | M6*10 | 6 | |
| 11 | 207085 | Cover | | 1 | VE |
| 12 | WF081818 | Washer | M8*18 | 8 | |
| 13 | SS080500 | Setscrew | M8*25 | 8 | |
| 15 | AB203348 | Roller Assembly | | 5 | |
| 18 | AB203356 | Ring Assembly | | 1 | |
| 20 | 206421 | Swing Arm | | 1 | VE |
| 21 | WF203730 | Washer | M20*37 | 1 | |
| 22 | BB600402A | Bearing | 6004ZZ | 2 | |
| 23 | 135051-A | Brush | | 2 | |
| 24 | WF061310 | Washer | M6*13 | 2 | |
| 25 | SR060400 | Cap Screw | M6*20 | 2 | |
| 26 | WF203730 | Washer | M20*37 | 1 | |
| 27 | 207084 | Plate | | 1 | VE |
| 28 | WS080000 | Spring Washer | M8 | 1 | |
| 29 | 203239 | Hex Nut | M8*1.25P | 1 | |
| 30 | SS100200 | Setscrew | M10*10 | 3 | |
| 31 | 207081 | Shaft | | 1 | |
| 32 | SS100400 | Setscrew | M10*20 | 4 | |
| 33 | NH101700 | Hex Nut | M10 | 4 | |
| 34 | NH081300 | Hex Nut | M8 | 8 | |
| 35 | 207582 | Cover | 13mm | 8 | |
| 36 | SJ059200 | Button Head Screw | M5*8 | 4 | |
| 37 | 207528 | Plate | | 1 | VE |
| 101 | 203349 | Shaft | | 1 | |
| 102 | 203348 | Roller | | 1 | |
| 103 | BB620202 | Bearing | 6202ZZ | 2 | |
| 104 | RS150000 | Ext. Retaining Ring | S15 | 2 | |
| 201 | BB620202 | Bearing | 6202ZZ | 1 | |
| 202 | 203356 | Ring | | 1 | |
| 203 | 203357 | Shaft | | 1 | |
| 204 | RS150000 | Ext. Retaining Ring | S15 | 2 | |

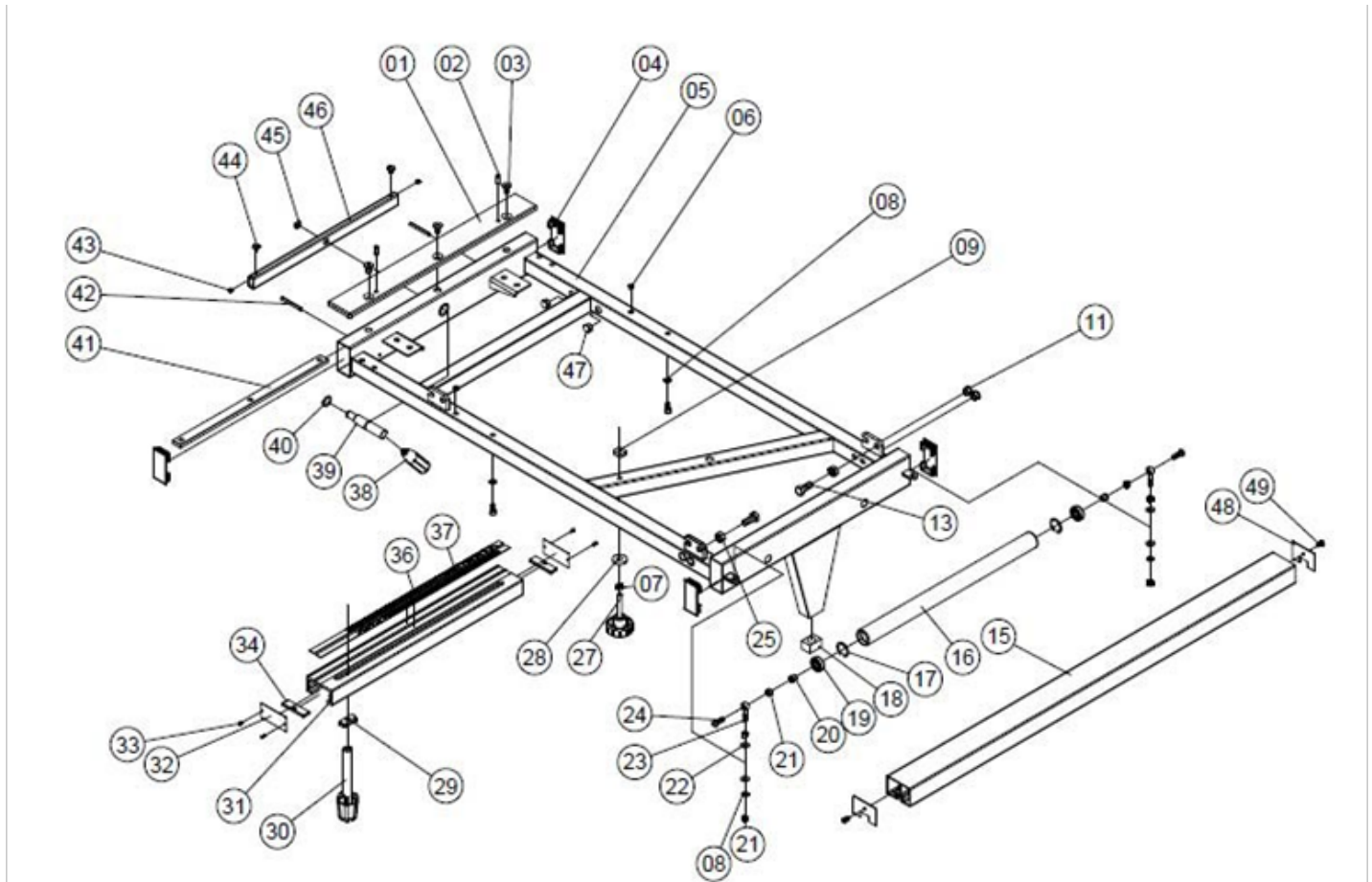

| Item | Part N° | Parts Name | Size | Qty | Note |
|------|----------|--------------------|-------------|-----|------|
| 1 | 203116 | Fixed Plate | | 1 | |
| 2 | PS082000 | Spring Pin | 8×20 | 2 | |
| 3 | SI100400 | Counter Sunk Screw | M10×20 | 3 | |
| 4 | 200910 | Plug | 40×80 | 4 | |
| 5 | 203979 | Frame | | 1 | R |
| 6 | 201576 | Hole Plugs | HP-09 | 2 | |
| 7 | NH081300 | Hex Nut | M8 | 1 | |
| 8 | WS080000 | Lock Washer | M8 | 4 | |
| 9 | 201103 | T-Nut | M8x1.25p | 1 | |
| 11 | 203284 | Hole Plugs | HP-19 | 4 | |
| 13 | SH120801 | Screw | M12×1.25×40 | 2 | |
| 15 | 200833 | Pipe | | 1 | |
| 16 | 203302 | Roller | | 1 | |
| 17 | RR320000 | Retaining Ring | R32 | 2 | |
| 18 | 203094 | Plug | | 1 | |

| Item | Part N° | Parts Name | Size | Qty | Note |
|------|-----------|-------------------|--------------|-----|------|
| 19 | BB620102A | Ball Bearing | 6201ZZ | 2 | |
| 20 | 017058 | Bearing | | 2 | |
| 21 | NH081300 | Hex Nut | M8 | 6 | |
| 22 | WF081818 | Washer | M8x18 | 4 | |
| 23 | 201542 | Eye Bolt | M8x40 | 2 | |
| 24 | SJ080500 | Button Head Screw | M8x25 | 2 | |
| 25 | NH121900 | Nut | M12 | 2 | |
| 27 | 200827 | Knob | M8x1.25px40L | 1 | |
| 28 | WF083020 | Washer | M8 | 1 | |
| 29 | 203122 | Block | | 1 | |
| 30 | 203128 | Handle | | 1 | |
| 31 | 203855 | Pipe | | 1 | X7 |
| 32 | 203856 | Plate | | 2 | |
| 33 | SJ039200 | Button Head Screw | M3x8 | 4 | |
| 34 | 203121 | Fixed Block | | 2 | |
| 36 | 207924-2 | Ruler | | 1 | |
| 37 | 207924-1 | Ruler | | 1 | |
| 38 | 203719 | Knob | | 1 | |
| 39 | 203114 | Eccentric Shaft | | 1 | |
| 40 | RS200000 | Retaining Ring | S20 | 1 | |
| 41 | 203288 | Fixed Block | | 1 | |
| 42 | PS066000 | Spring Pin | 6x60 | 2 | |
| 43 | NS050800 | Square Nut | M5 | 2 | |
| 44 | 203110 | Screw | M5x10 | 2 | |
| 45 | RS140000 | Retaining Ring | S14 | 1 | |
| 46 | 203109 | Square Pipe | | 1 | |
| 47 | 203230 | Hole Plugs | HP-16 | 2 | |
| 48 | 200955 | Cover | | 2 | |
| 49 | ST040200 | Tap Screw | #8x3/8" | 2 | |
| 43 | NS050800 | Square Nut | M5 | 2 | |
| 44 | 203110 | Screw | M5x10 | 2 | |
| 45 | RS140000 | Retaining Ring | S14 | 1 | |
| 46 | 203109 | Square Pipe | | 1 | |
| 47 | 203230 | Hole Plugs | HP-16 | 2 | |

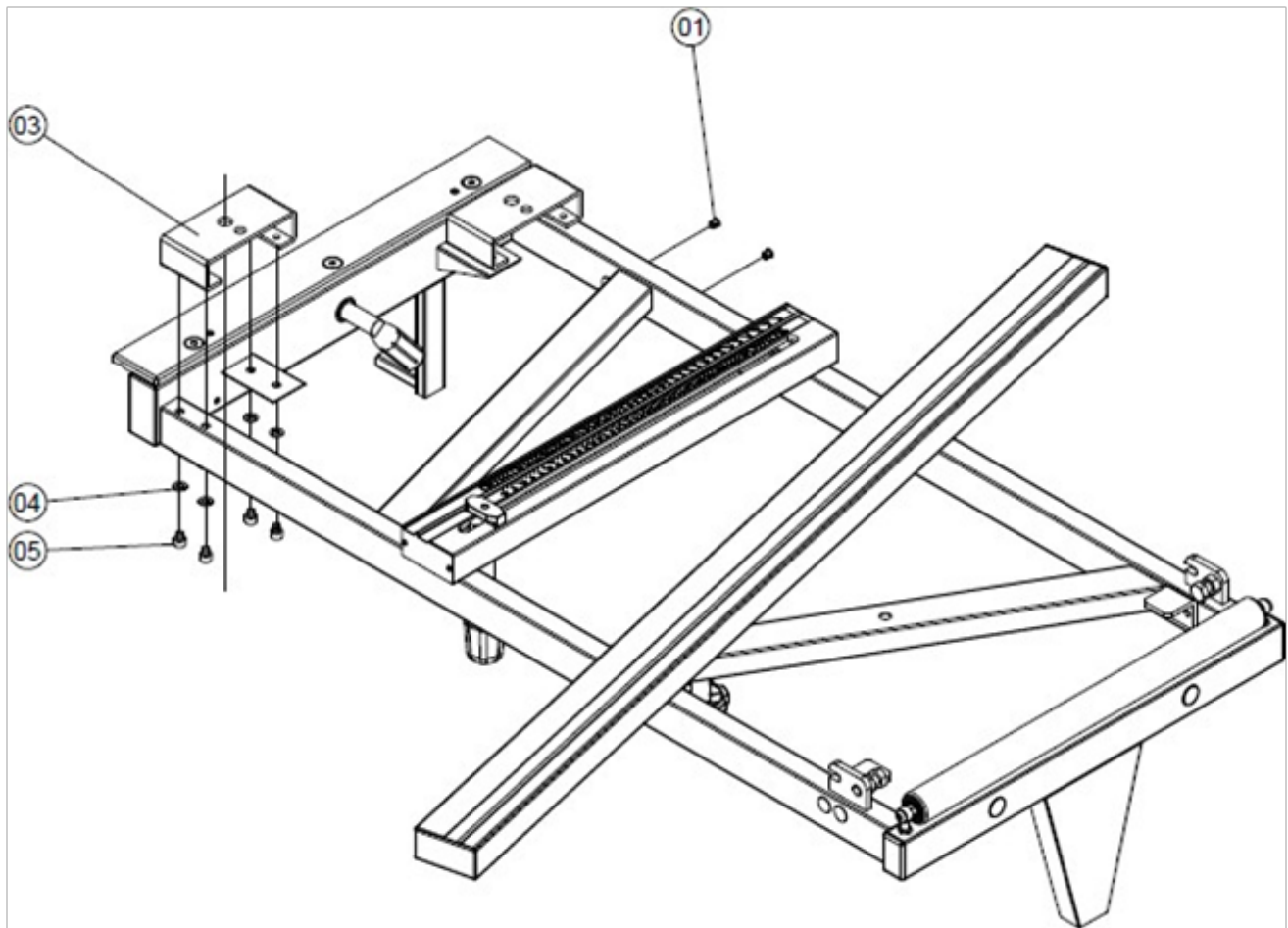

| Item | Part N° | Parts Name | Size | Qty | Note |
|------|----------|-------------|-------|-----|------|
| 1 | 201576 | Hole Plugs | HP-09 | 2 | |
| 3 | 207734 | Fixed Plate | | 2 | R |
| 4 | WS080000 | Lock Washer | M8 | 8 | |
| 5 | SR080200 | Cap Screw | M8×10 | 8 | |

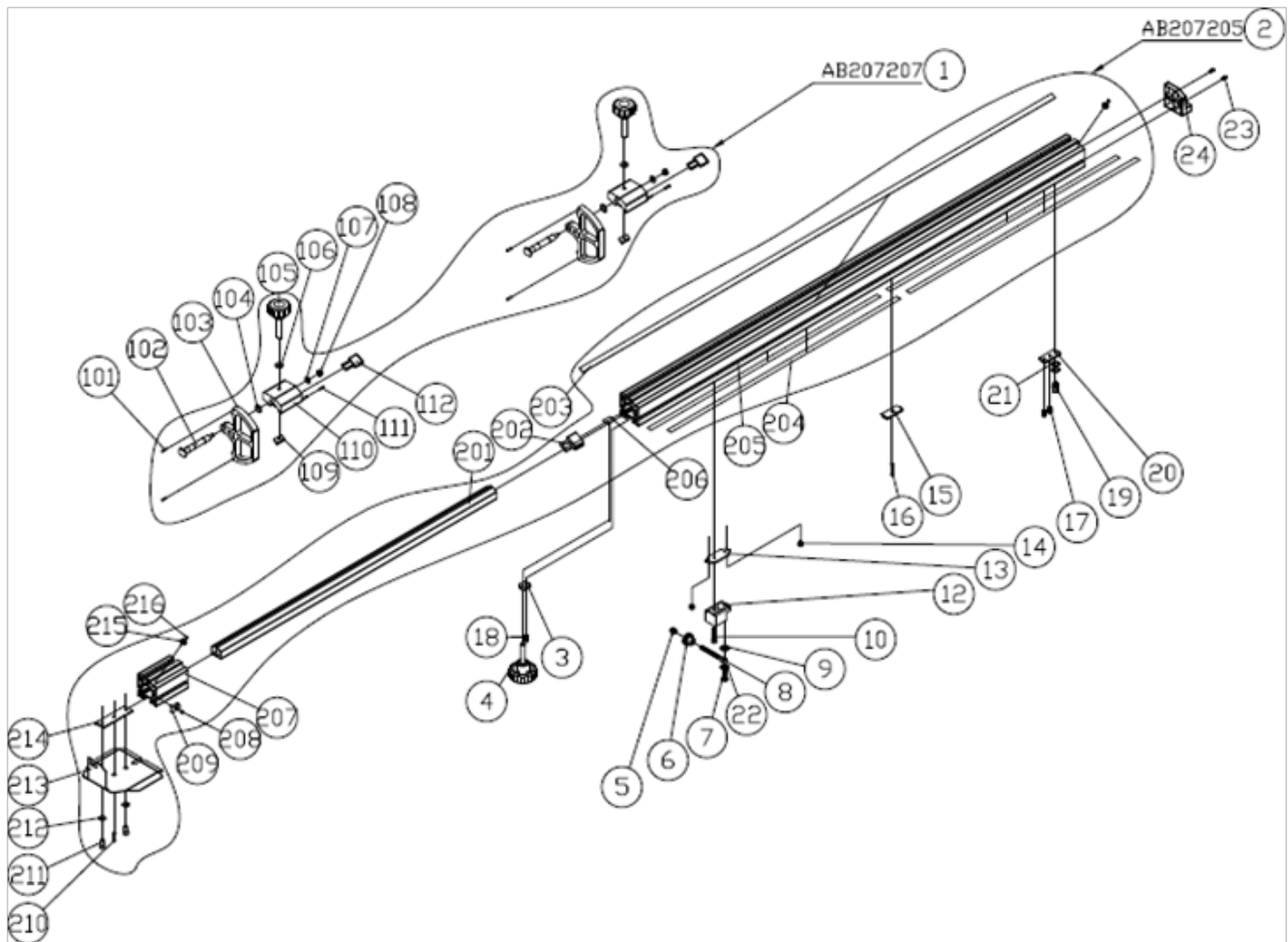

| Item | Part N° | Parts Name | Size | Qty | Note |
|------|-----------|---------------------|--------------|-----|-------------|
| 1 | AB207207 | Flip Stop Assembly | | 2 | A |
| 2 | AB207205A | Ext. Fence Assembly | mm | 1 | S, standard |
| | AB207205 | Ext. Fence Assembly | mm/inch | 1 | S, A |
| 3 | 207222 | Block | | 1 | H |
| 4 | 200827 | Knob | M8x1.25px40L | 1 | H |
| 5 | NA081300 | Nut | M8 | 1 | |
| 6 | 203790 | Knob | M8*1.25p | 1 | |
| 7 | SJ080400 | Button Head Screw | M8*20 | 1 | |
| 8 | 203598 | Screw | M8*1.25p | 1 | |
| 9 | WF081818 | Washer | M8*18 | 1 | |
| 10 | SR060800 | Cap Screw | M6*40 | 1 | |
| 12 | 207219 | Fixed Block | | 1 | |
| 13 | 207220 | Plate | | 1 | |

| Item | Part N° | Parts Name | Size | Qty | Note |
|------|----------|---------------|--------------|-----|------------|
| 14 | SS069100 | Setscrew | M6*6 | 2 | |
| 15 | 207218 | Fixed Block | | 1 | H |
| 16 | SS080700 | Setscrew | M8*35 | 1 | H |
| 17 | SS089300 | Setscrew | M8*12 | 2 | H |
| 18 | SS089300 | Setscrew | M8*12 | 1 | H |
| 19 | 200832 | Rotate Shaft | | 1 | H |
| 20 | 207737 | Fixed Block | | 1 | H |
| 21 | 200069 | Fiber Washer | 10x18 | 2 | H |
| 22 | 992601 | Copper Washer | 8*16*0.2 | 1 | |
| 23 | ST049200 | Tap Screw | M4x8 | 2 | |
| 24 | 207851 | Rotate Block | | 1 | |
| 101 | 207223 | Pipe | | 2 | |
| 102 | 207203 | Shaft | | 1 | |
| 103 | 207207 | Flip Stop | | 1 | |
| 104 | 207208 | Washer | | 1 | |
| 105 | 207263 | Knob | M8x1.25px42L | 1 | |
| 106 | 200472 | Washer | M8x20x1 | 1 | |
| 107 | WF081818 | Washer | M8x18 | 1 | |
| 108 | 207235 | Nut | M8 | 1 | |
| 109 | 207200 | Nut | | 1 | |
| 110 | 207201 | Stop Bracket | | 1 | |
| 111 | 207223 | Pipe | | 2 | |
| 112 | 207202 | Magnifier | | 1 | |
| 201 | 207212-1 | Extended Tube | mm | 1 | S,standard |
| | 207212 | Extended Tube | mm/inch | 1 | S |
| 202 | 207213 | Magnifier | | 1 | |
| 203 | 207216-1 | Rule | mm | 1 | S,standard |
| | 207216 | Rule | mm/inch | 1 | S |
| 204 | 205544 | Wearing Tape | 875x15 | 4 | |
| 205 | 207205-1 | Ext. Fence | | 1 | |
| 206 | 207884 | Sheet | | 1 | |
| 207 | 207205-2 | Ext. Fence | | 1 | |
| 208 | SS069100 | Setscrew | M6x6 | 1 | |
| 209 | 207211 | Stop Block | | 1 | |
| 210 | SS080500 | Setscrew | M8x25 | 1 | |
| 211 | SR089400 | Cap Screw | M8x16 | 2 | |

| Item | Part N° | Parts Name | Size | Qty | Note |
|------|----------|--------------|-------|-----|------|
| 212 | WF081818 | Washer | M8x18 | 2 | |
| 213 | 207210 | Locate Plate | | 1 | |
| 214 | 207209 | Plate | | 1 | |
| 215 | 207204 | Nut | | 2 | |
| 216 | SS050100 | Setscrew | M5x5 | 2 | |

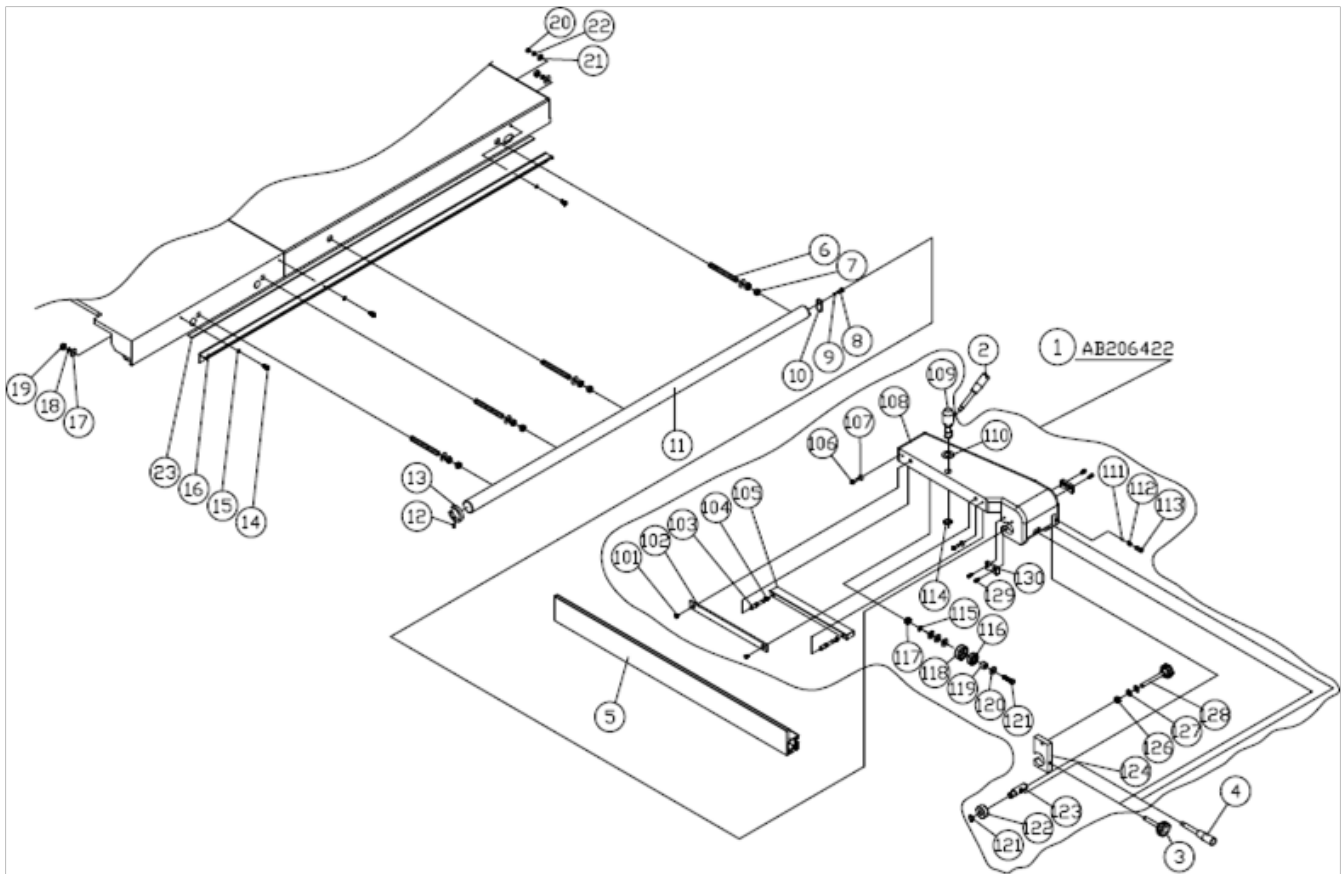

| Item | Part N° | Parts Name | Size | Qty | Note |
|------|----------|----------------------------|----------------|-----|--------|
| 1 | AB206422 | Rip Fence Housing Assembly | | 1 | A |
| 2 | 200884 | Handle | | 1 | |
| 3 | 206432 | Knob Screw | M10*1.5p*55L | 1 | |
| 4 | 200884 | Handle | | 1 | |
| 5 | 205663 | Fence Plate | 1M | 1 | |
| | 203191 | Fence Plate | 1.2M | 1 | X7 / S |
| 6 | 200881 | Screw | M12x1.75px115L | 4 | |

| Item | Part N° | Parts Name | Size | Qty | Note |
|------|----------|---------------------|------------|-----|----------|
| 7 | NH121900 | Hex Nut | M12 | 8 | |
| 8 | SR089300 | Cap Screw | M8x16 | 1 | |
| 9 | WS080000 | Lock Washer | M8 | 1 | |
| 10 | 206437 | End Washer | | 1 | |
| 11 | 201004 | Round Rail | | 1 | |
| 12 | SS060200 | Setscrew | M6x10 | 1 | |
| 13 | 200957 | Ring Stop | | 1 | |
| 14 | SJ069300 | Button Head Screw | M6*12 | 3 | H |
| 15 | WF061620 | Washer | M6*16 | 3 | H |
| 16 | 207984 | Measuring Rule Rail | | 1 | |
| 17 | WF132225 | Washer | M13x22x2.5 | 8 | |
| 18 | WS120000 | Lock Washer | M12 | 4 | |
| 19 | NH121900 | Hex Nut | M12 | 4 | |
| 20 | NH061000 | Hex Nut | M6 | 1 | H |
| 21 | WF061620 | Washer | M6x16x2 | 1 | H |
| 22 | WS060000 | Lock Washer | M6 | 1 | H |
| 23 | LM206306 | Ruler | mm | 1 | standard |
| | LM001042 | Ruler | mm/inch | 1 | S |
| 101 | SI069400 | Counter Sunk Screw | M6*16 | 2 | |
| 102 | 206433 | Fixed Plate | | 1 | |
| 103 | 203193 | Shafts | | 2 | |
| 104 | NL081000 | Lock Nut | M8 | 2 | |
| 105 | 200875 | Plate | | 1 | |
| 106 | SH069400 | Hex Head Bolt | M6*16 | 2 | |
| 107 | 203179 | Eccentric Ring | | 2 | |
| 108 | 206422 | Seat | | 1 | GK |
| 109 | 203213 | Eccentric Shaft | | 1 | |
| 110 | WF203630 | Washer | 20*36 | 1 | |
| 111 | 994181 | Steel Ball | 8 | 1 | |
| 112 | 150099 | Spring | | 1 | |
| 113 | SS100200 | Set Screw | M10*10 | 1 | |
| 114 | RS200000 | Retaining Ring | S20 | 1 | |
| 115 | WS080000 | Lock Washer | M8 | 1 | |
| 116 | BB620202 | Ball Bearing | 6202ZZ | 1 | |
| 117 | NA081300 | Hex Nut | M8 | 1 | |
| 118 | 203356 | Ring | | 1 | |
| 119 | 206435 | Ring | | 1 | |

| Item | Part N° | Parts Name | Size | Qty | Note |
|------|----------|----------------|---------|-----|------|
| 121 | SH080700 | Hex Head Bolt | M8*35 | 1 | |
| 122 | RS150000 | Retaining Ring | S15 | 1 | |
| 123 | 203649 | Ring | | 1 | |
| 124 | 203650 | Shaft | | 1 | |
| 125 | 206428 | Fixed Block | | 1 | |
| 126 | NL101700 | Lock Nut | M10 | 1 | |
| 127 | 200069 | Washer | M10 | 2 | |
| 128 | 205114 | Adjust Knob | M10*110 | 1 | |
| 129 | SR060200 | Cap Screw | M6*10 | 4 | |
| 130 | 205822 | Scraper | 40 | 2 | |

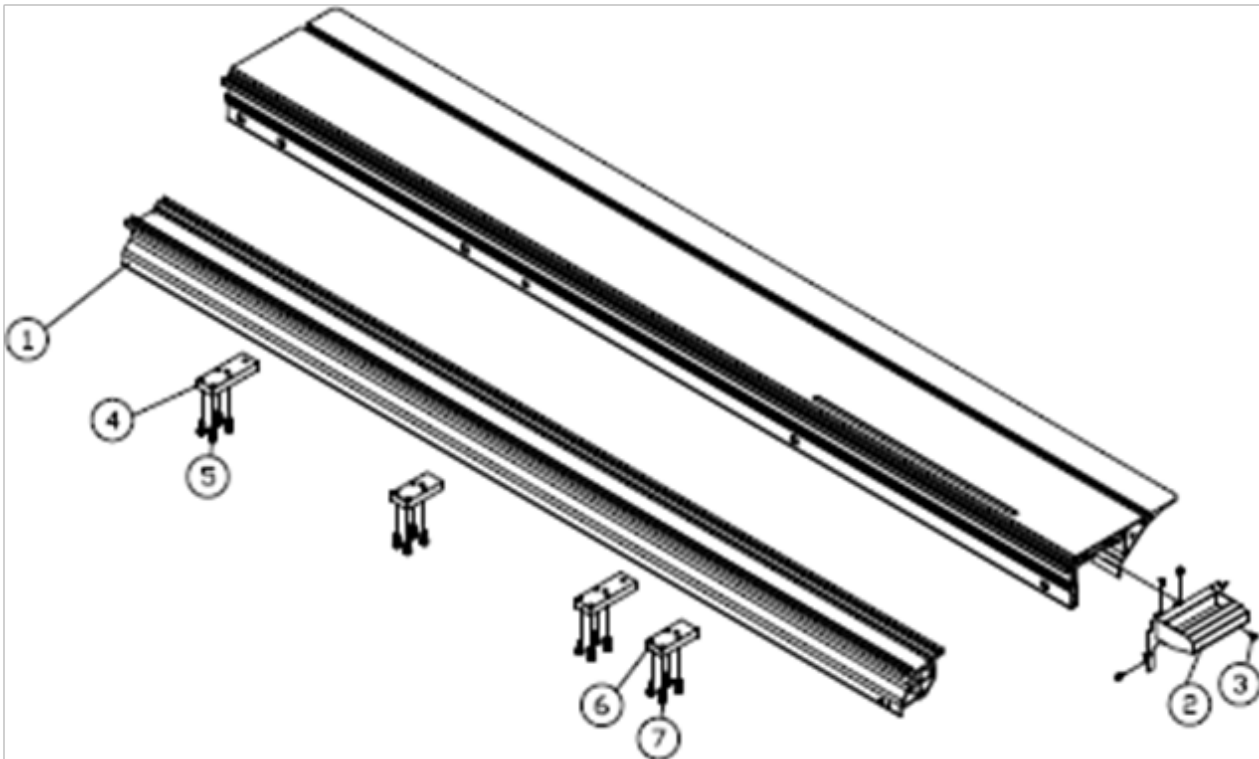

| Item | Part N° | Parts Name | Size | Qty | Note |
|------|----------|---------------|------------|-----|------|
| 1 | 2395250D | Table | 395x2500mm | 1 | S |
| 2 | 203423 | Hander | | 1 | T3 |
| 3 | SH050200 | Hex Head Bolt | M5*10 | 4 | |
| 4 | 203520 | Fixed Block | | 2 | |
| 5 | SR080500 | Cap Screw | M8*25 | 8 | |
| 6 | 205246 | Fixed Block | | 2 | |
| 7 | SR080500 | Cap Screw | M8*25 | 8 | |

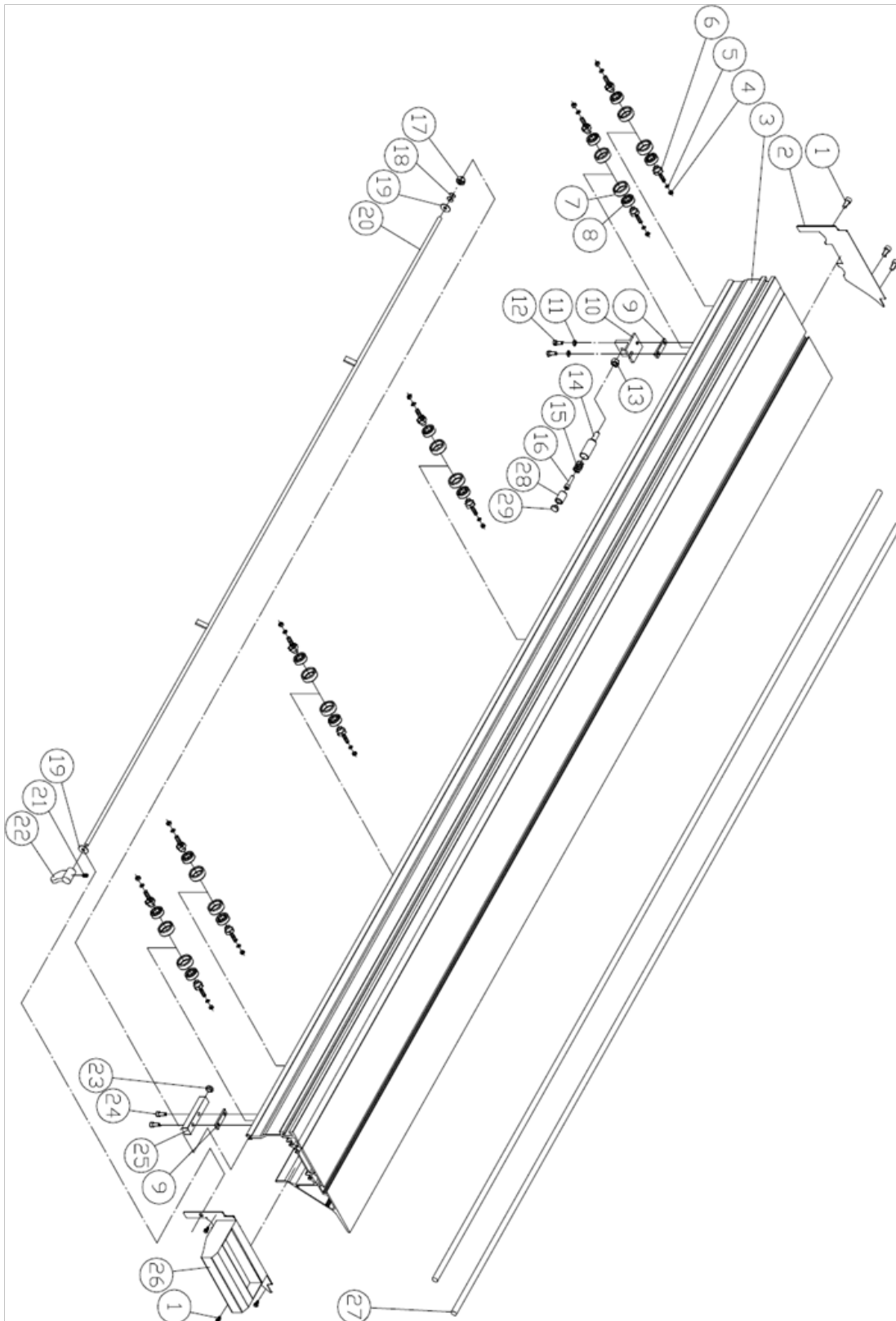

| Item | Part N° | Parts Name | Size | Qty | Note |
|------|-------------|-----------------|----------|-----|------|
| 1 | SJ069300 | Screw | M6*12 | 6 | |
| 2 | 2375320M-1 | Plate | | 1 | T3 |
| 3 | 2375320M-2 | Base | | 1 | |
| 4 | NH101700 | Hex Nut | M8 | 12 | |
| 5 | WE100000 | | M10 | 12 | |
| 6 | 2375320M-3 | Eccentric shaft | | 12 | |
| 7 | 203356 | Ring | | 12 | |
| 8 | BB620202 | Ball Bearing | 6202ZZ | 12 | |
| 9 | 203703 | Block | | 2 | |
| 10 | 203555 | Fixed Base | | 1 | |
| 11 | WS080000 | Lock Washer | M8 | 2 | |
| 12 | SH080400 | Hex Head Bolt | M8*20 | 2 | |
| 13 | NH101700 | Hex Nut | M10 | 1 | |
| 14 | 2375320M-4 | Spring | | 1 | |
| 15 | 2375320M-5 | Ring | | 1 | |
| 16 | SR101000 | Cap Screw | M10*50 | 1 | |
| 17 | NL101700 | Lock Nut | M10 | 1 | |
| 18 | 204263 | Set Screw | 10*20 | 2 | |
| 19 | WF102010 | Washer | 10*20*1t | 2 | |
| 20 | 2375320M-6 | Lever | | 1 | |
| 21 | SS069200 | Setscrew | M6*8 | 1 | |
| 22 | 2375320M-7 | Hander | | 1 | |
| 23 | 2375320M-8 | Base | | 1 | |
| 24 | SR100400 | Cap Screw | M10*20 | 2 | |
| 25 | 2375320M-9 | Fixed Block | | 1 | |
| 26 | 2375320M-10 | Hander | | 1 | T3 |
| 27 | 2375320M-11 | Cylinder | | 2 | |
| 28 | 2375320M-12 | Ring | | 1 | |
| 29 | 2375320M-13 | Base | | 1 | |

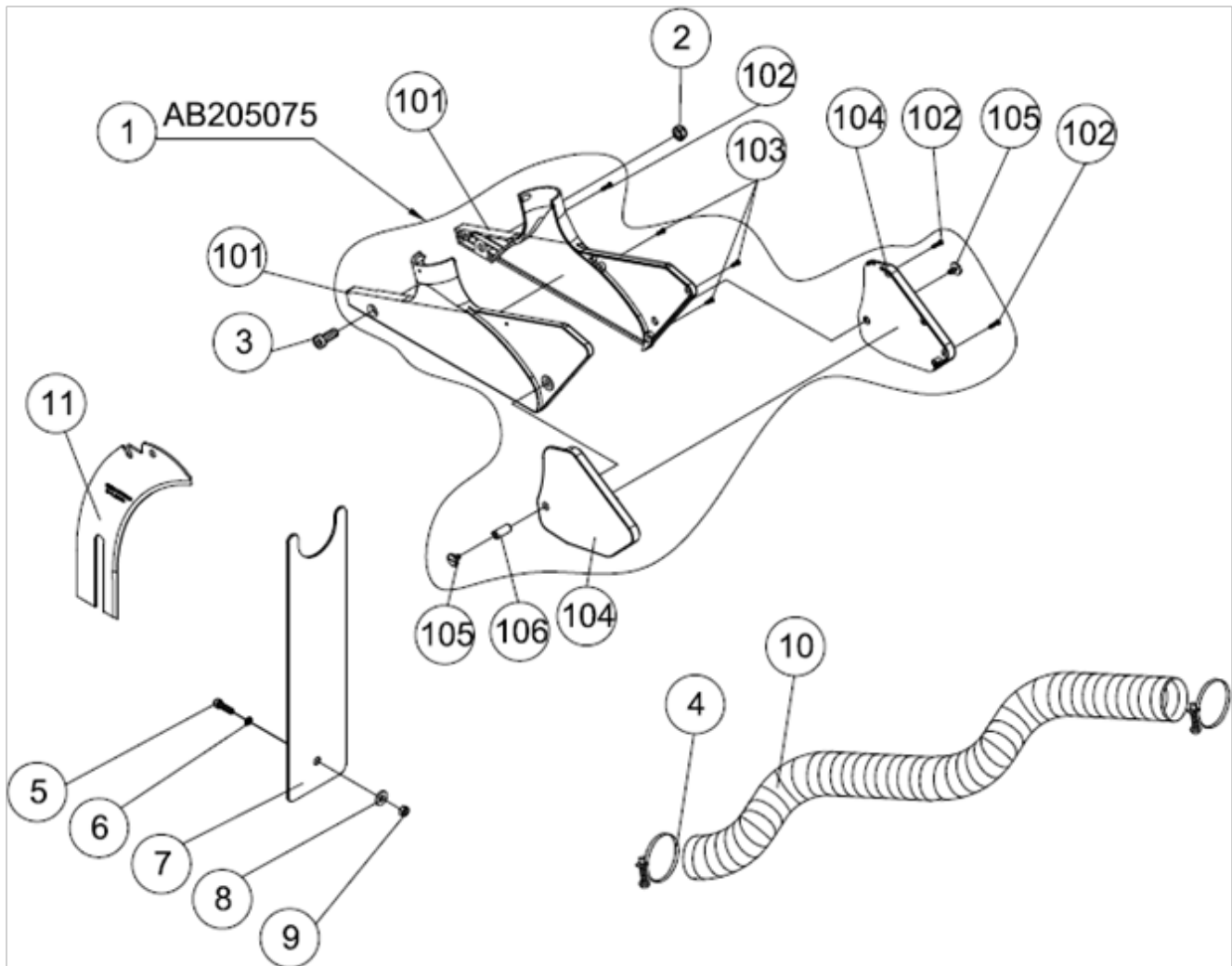

| Item | Part N° | Parts Name | Size | Qty | Note |
|------|----------|--------------------|----------|-----|------|
| 1 | AB205075 | Hood Assembly | | 1 | A |
| 2 | NL101700 | Lock Nut | M10 | 1 | |
| 3 | 205162 | Cap Screw | M10x25 | 1 | |
| 4 | 200535 | Hose Clamp | 2-1/2" | 2 | |
| 5 | SR100500 | Cap Screw | M10x25 | 1 | |
| 6 | WS100000 | Lock Washer | M10 | 1 | |
| 7 | 200965 | Hose Support Plate | | 1 | |
| 8 | WF102025 | Washer | M10x20 | 1 | |
| 9 | NL101700 | Hex Nut | M10 | 1 | |
| 10 | 200536 | Hose | ∅64x3000 | 1 | |
| 11 | 205067 | Plate | | 1 | |

| Item | Part N° | Parts Name | Size | Qty | Note |
|-------------|----------------|-------------------|-------------|------------|-------------|
| 101 | 205075 | Hood | | 1 | |
| 102 | ST029404 | Screw | M3×16 | 3 | |
| 103 | ST029304 | Screw | M3×12 | 3 | |
| 104 | 205076 | Hood | | 1 | |
| 105 | 203110 | Screw | M5×10 | 2 | |
| 106 | 205124 | Shaft | | 1 | |

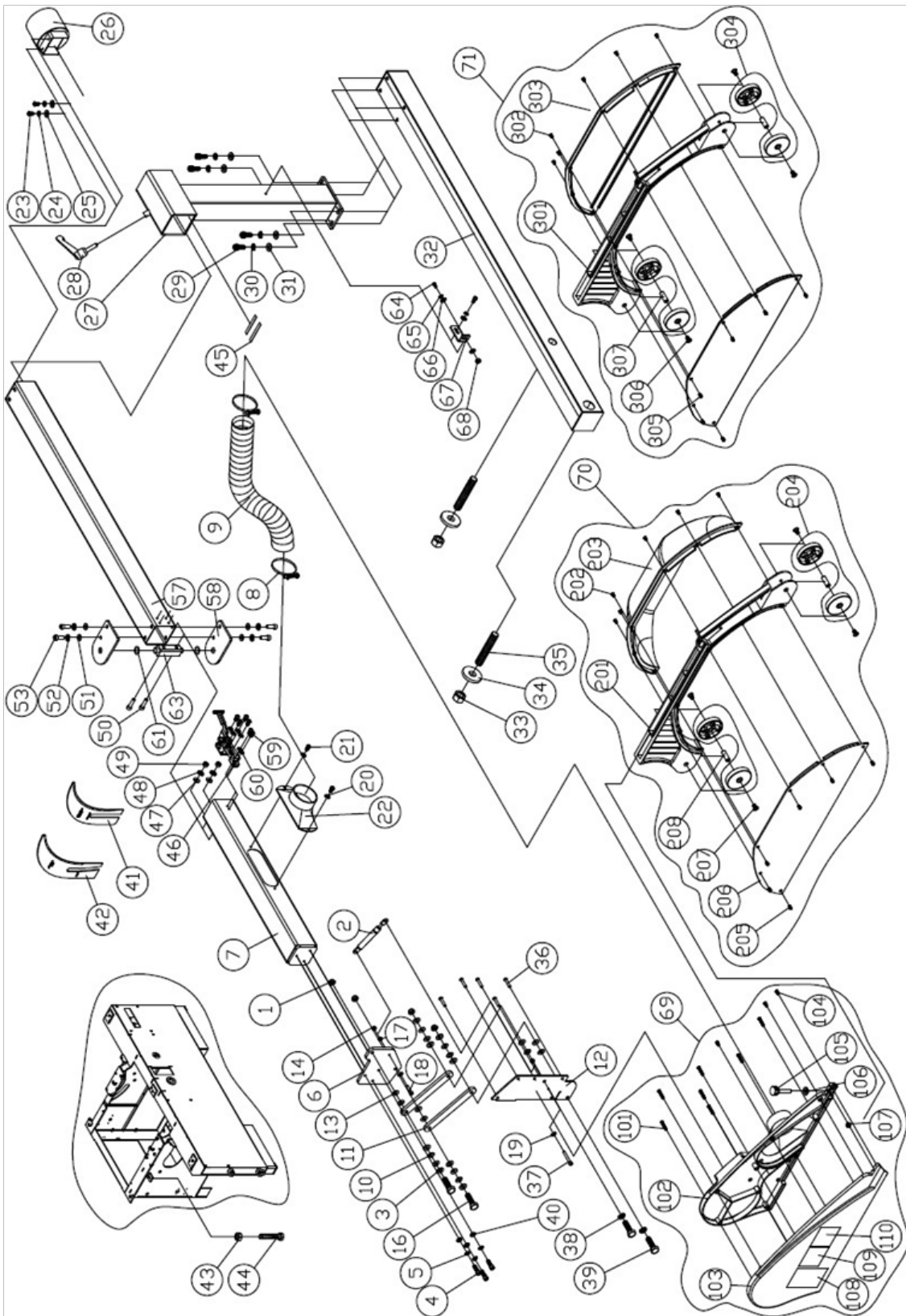

| Item | Part N° | Parts Name | Size | Qty | Note |
|------|----------|------------------------|------------|-----|------|
| 1 | NL101700 | Lock Nut | M10 | 4 | |
| 2 | 205004 | Gas Expansion Cylinder | | 1 | |
| 3 | WF102020 | Washer | M10*20 | 8 | |
| 4 | SR060400 | Cap Screw | M6*20 | 3 | H |
| 5 | WS060000 | Lock Washer | M6 | 3 | H |
| 6 | 207987 | Fixed Plate | | 1 | |
| 7 | 207970 | Arm | | 1 | R |
| 8 | 204158 | Hose Clamp | 3-1/4" | 2 | |
| 9 | HS330004 | Hose | 3"x42cm | 1 | |
| 10 | 204263 | Washer | 10x20 | 8 | |
| 11 | 207981 | Link | | 2 | |
| 12 | 207985 | Fixed Plate | | 1 | |
| 13 | 992609 | Copper Washer | 20x10x0.5t | 8 | |
| 14 | NL061000 | Lock Nut | M6 | 2 | |
| 16 | SH100700 | Hex Head Bolt | M10*35 | 2 | |
| 17 | NH061000 | Hex Nut | M6 | 1 | |
| 18 | SR060500 | Cap Screw | M6*25 | 1 | |
| 19 | WS060000 | Lock Washer | M6 | 2 | |
| 20 | WS060000 | Lock Washer | M6 | 2 | H |
| 21 | SJ069300 | Cap Screw | M6*12 | 2 | H |
| 22 | 204061 | Dust Port | | 1 | |
| 23 | SJ069300 | Cap Screw | M6*12 | 2 | |
| 24 | WS060000 | Lock Washer | M6 | 2 | |
| 25 | WF061920 | Washer | M6*19 | 2 | |
| 26 | 206390 | Dust Port | | 1 | R |
| 27 | 206388 | Fixed Bracket | | 1 | R |
| 28 | 201109 | Fasten Handle | M10x35 | 1 | H |
| 29 | SR080500 | Cap Screw | M8x25 | 4 | H |
| 30 | WS080000 | Lock Washer | M8 | 4 | H |
| 31 | WF081818 | Washer | M8x18 | 4 | H |
| 32 | 206391 | Fixed Bracket | | 1 | R |
| 33 | NH203000 | Hex Nut | M20 | 2 | |
| 34 | 203338 | Washer | 22*60*t8 | 2 | |
| 35 | 205116 | Screw | M20*130 | 2 | |
| 36 | SJ060600 | Button Head Screw | M6*30 | 5 | |
| 37 | SR060900 | Cap Screw | M6*45 | 1 | |
| 38 | WS100000 | Lock Washer | M10 | 2 | |

| Item | Part N° | Parts Name | Size | Qty | Note |
|------|----------|---------------------|------------|-----|------|
| 39 | SH100700 | Hex Head Bolt | M10*35 | 2 | |
| 40 | WF061920 | Washer | M6*19 | 3 | H |
| 41 | 205073 | Plate | 300~350 | 1 | |
| 42 | 205032 | Plate | 350~400 | 1 | S |
| 43 | NH121900 | Hex Nut | M12 | 1 | |
| 44 | SH121400 | Hex Head Bolt | M12X70 | 1 | |
| 45 | 201039 | Pad | | 8 | |
| 46 | 205358 | Elbow Type Clamp | | 1 | |
| 47 | WF081818 | Washer | M8x18 | 2 | |
| 48 | WS080000 | Lock Washer | M8 | 2 | |
| 49 | NH081300 | Hex Nut | M8 | 2 | |
| 50 | SR080600 | Cap Screw | M8x30 | 2 | |
| 51 | WF081818 | Washer | M8x18 | 4 | |
| 52 | WS080000 | Lock Washer | M8 | 4 | |
| 53 | SR080500 | Cap Screw | M8x25 | 4 | |
| 57 | 207971 | Square Tube | | 1 | R |
| 58 | 207973 | Plate | | 2 | R |
| 59 | SJ060200 | Cap Screw | M6x10 | 6 | |
| 60 | WS060000 | Lock Washer | M6 | 6 | |
| 61 | 992627 | Copper Washer | 24*16*0.3t | 2 | |
| 63 | 207975 | Shaft | | 1 | |
| 64 | SR060400 | Cap Screw | M6*20 | 2 | |
| 65 | WS060000 | Lock Washer | M6 | 2 | |
| 66 | WF061620 | Washer | M6×16 | 3 | |
| 67 | 207776 | Fixed Plate | | 1 | |
| 68 | NH061000 | Hex Nut | M6 | 1 | |
| 69 | AB207866 | Rear Cover ASM | | 1 | |
| 70 | AB205355 | Protection Hood ASM | | 1 | |
| 71 | AB205356 | Protection Hood ASM | | | |
| 101 | ST030500 | Tap Screw | M3.5x25 | 7 | |
| 102 | 207866 | Rear Cover | | 1 | |
| 103 | 207865 | Front Cover | | 1 | |
| 104 | ST040200 | Tap Screw | M4x10 | 3 | |
| 105 | 207882 | Knob | | 1 | |
| 106 | WF081818 | Washer | M8x18 | 1 | |
| 107 | NH081300 | Hex Nut | M8 | 1 | |
| 108 | LM207031 | Warning Label | | 1 | |

| Item | Part N° | Parts Name | Size | Qty | Note |
|------|----------|--------------------|-------|-----|------|
| 109 | LM207032 | Warning Label | | 1 | |
| 110 | LM207033 | Warning Label | | 1 | |
| 201 | 207867 | Guard | | 1 | |
| 202 | SP040200 | Pan Head Screw | M4*10 | 6 | |
| 203 | 205355 | Protection Hood | | 1 | |
| 204 | AB207868 | Roller ASM | | 2 | |
| 205 | SP040200 | Pan Head Screw | M4*10 | 6 | |
| 206 | 205356 | Protection Hood | | 1 | |
| 207 | SI060200 | Counter Sunk Screw | M6*10 | 4 | |
| 208 | 207883 | Shaft | | 2 | |
| 301 | 207867 | Guard | | | |
| 302 | SP040200 | Pan Head Screw | M4*10 | | |
| 303 | 205356 | Protection Hood | | | |
| 304 | AB207868 | Roller ASM | | | |
| 305 | SP040200 | Pan Head Screw | M4*10 | | |
| 306 | SI060200 | Counter Sunk Screw | M6*10 | | |
| 307 | 207883 | Shaft | | | |

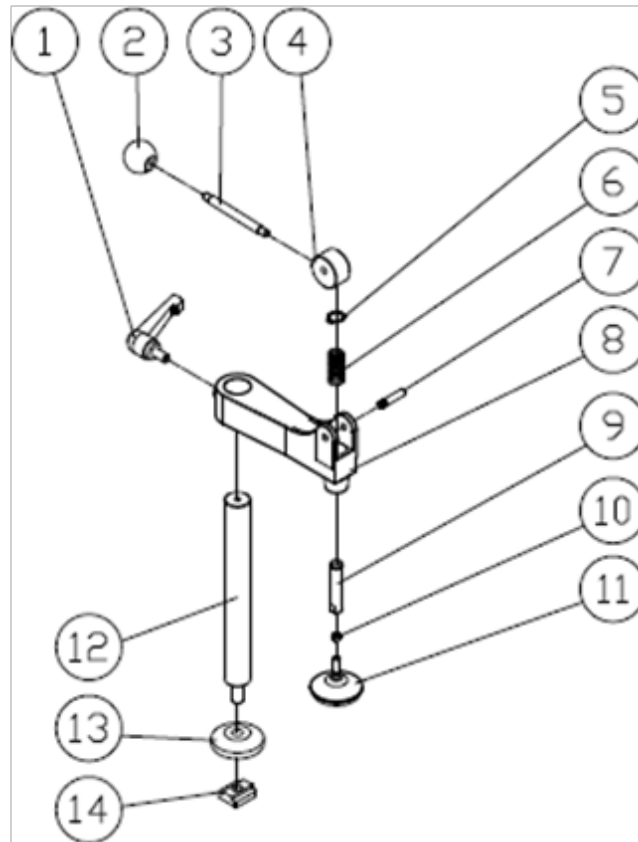

| Item | Part N° | Parts Name | Size | Qty | Note |
|------|----------|---------------------|----------|-----|------|
| 1 | 207143 | Adjust Handle | | 1 | |
| 2 | 100271 | Ball Knob | M8×P1.25 | 1 | |
| 3 | 207070 | Handle Bar | | 1 | |
| 4 | 207067 | Cam | | 1 | |
| 5 | RS140000 | Ext. Retaining Ring | S14 | 1 | |
| 6 | 207069 | Spring | | 1 | |
| 7 | 207145 | Pin | | 1 | |
| 8 | 207065 | Down Press | | 1 | |
| 9 | 207068 | Shaft | | 1 | |
| 10 | NH602300 | Hex Nut | 5/16 | 1 | |
| 11 | 200807 | Large Washer | | 1 | |
| 12 | 205253 | Shaft | | 1 | |
| 13 | 200809 | Washer | | 1 | |
| 14 | 201855 | T-Nut | | 1 | S, B |
| | 205255 | T-Nut | | 1 | S, D |

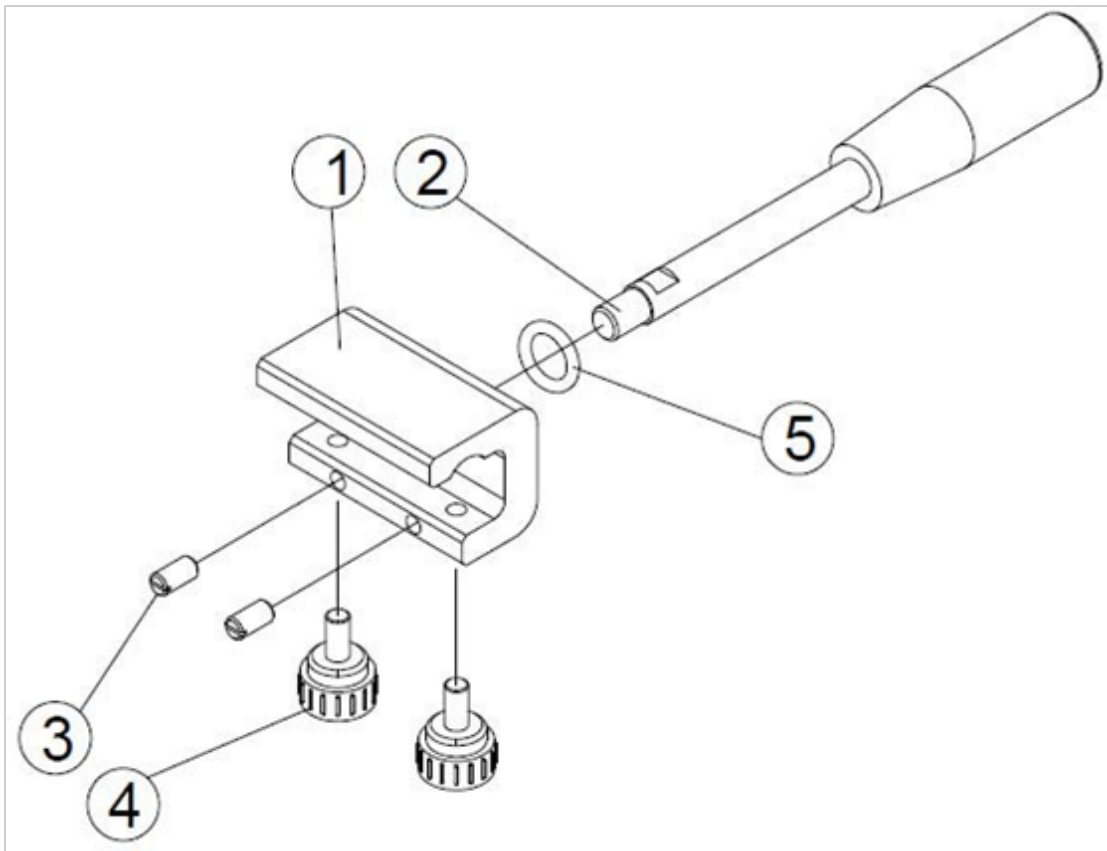

| Item | Part N° | Parts Name | Size | Qty | Note |
|------|----------|----------------|-----------|-----|-----------|
| 1 | 205264 | Block | | 1 | |
| 2 | 200939 | Handle | | 1 | |
| 3 | 203238 | Set Screw | M8×16 | 2 | D Sliding |
| | SS080500 | Set Screw | M8x25 | 2 | C Sliding |
| 4 | 203720 | Knob | M8×16 | 2 | |
| 5 | 992492 | PLASTIC WASHER | 12x30 t=3 | 1 | |

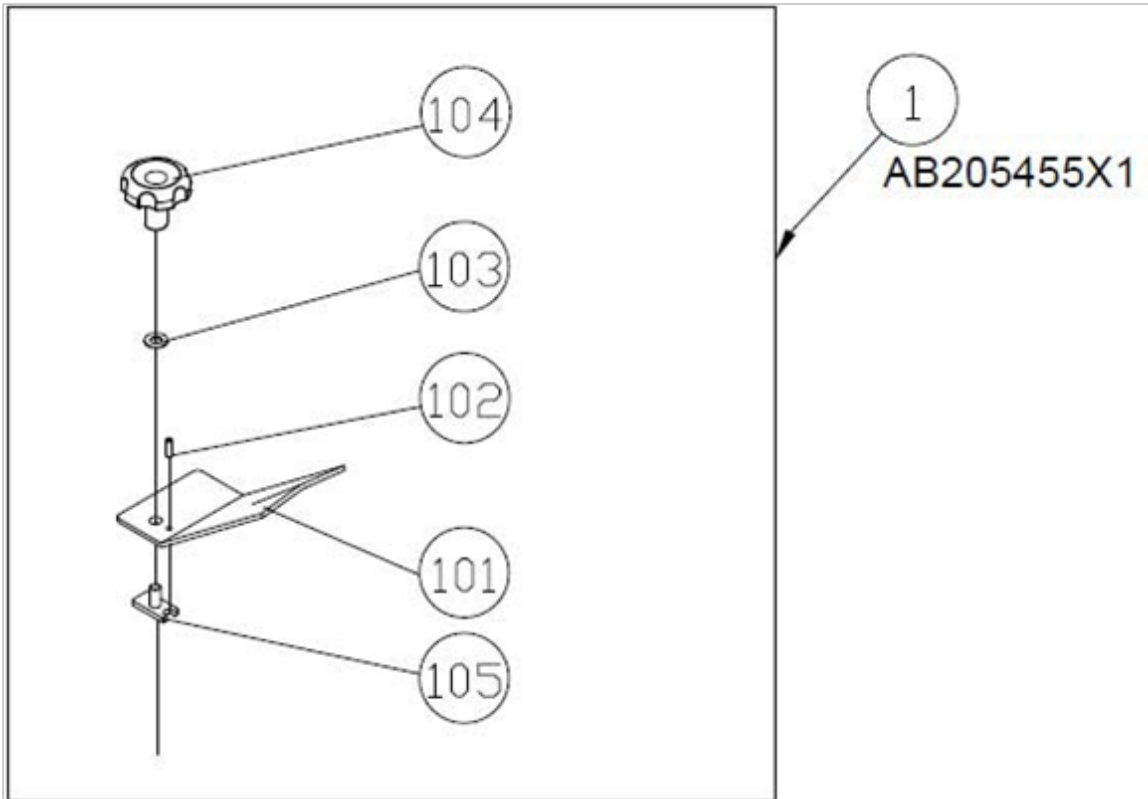

| Item | Part N° | Parts Name | Size | Qty | Note |
|------|------------|--------------------------|----------|-----|------|
| 1 | AB205455X1 | Edge Shoe Plate Assembly | | 1 | |
| 101 | 205455 | Edge Shoe Plate | | 1 | X1 |
| 102 | PS051800 | Spring Pin | 5x18 | 1 | |
| 103 | WF102025 | Washer | M10x25 | 1 | |
| 104 | 203718 | Knob | M10 | 1 | |
| 105 | 201829 | T-Nut | M10x1.5p | 1 | |

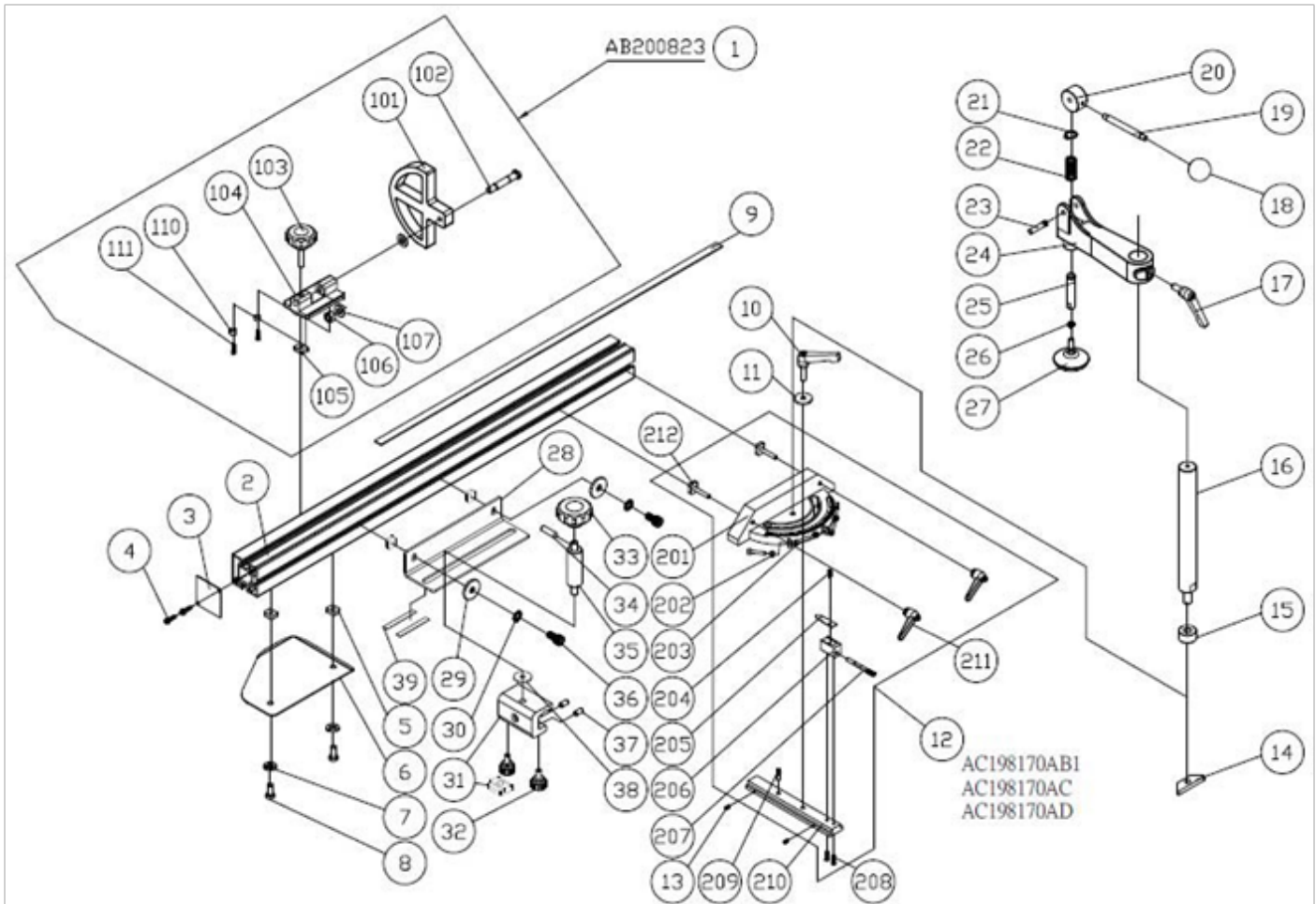

| Item | Part N° | Parts Name | Size | Qty | Note |
|------|-------------|----------------------|----------------------------|-----|-------------|
| 1 | AB200823 | Flip Stop Assembly | 101-111 | 1 | A |
| 2 | 205758 | Square Fence | | 1 | |
| 3 | 200830 | Cover | | 1 | |
| 4 | ST040200 | Tap Screw | M4x10 | 2 | |
| 5 | 201103 | T-Nut | M8x1.25p | 4 | |
| 6 | 205715 | Locate Plate | | 1 | |
| 7 | WS080000 | Lock Washer | M8 | 2 | |
| 8 | SJ089400 | Button Head Screw | M8x16 | 2 | |
| 9 | LM200143 | Rule | From right 0-1000(mm/inch) | 1 | S, standard |
| | LM200149 | Rule | from right 0-1000(m) | 1 | S |
| 10 | 200814 | Fasten Handle | | 1 | |
| 11 | WF083030 | Flat Washer | M8x30 | 1 | |
| 12 | AC198170AB1 | Miter Gauge Assembly | For B1,F type | 1 | S, A |
| | AC198170AC | Miter Gauge Assembly | For C type | 1 | S, A |
| | AC198170AD | Miter Gauge Assembly | For D type | 1 | S, A |

| Item | Part N° | Parts Name | Size | Qty | Note |
|------|----------|---------------------------|-------------|-----|-------|
| 13 | 201632 | Spring plungers with ball | M4×9 | 2 | |
| 14 | 207666 | Locate Plate | | 1 | |
| 15 | 207668 | Ring | | 1 | |
| 16 | 205253 | Shaft | | 1 | |
| 17 | 207143 | Adjust Handle | | 1 | |
| 18 | 100271 | Ball Knob | M8×P1.25 | 1 | |
| 19 | 207070 | Handle Bar | | 1 | |
| 20 | 207067 | Cam | | 1 | |
| 21 | RS140000 | Ext. Retaining Ring | S14 | 1 | |
| 22 | 207069 | Spring | | 1 | |
| 23 | 207145 | Pin | | 1 | |
| 24 | 207065 | Down Press | | 1 | |
| 25 | 207068 | Shaft | | 1 | |
| 26 | NH602300 | Hex Nut | 5/16 | 1 | |
| 27 | 200807 | Large Washer | | 1 | |
| 28 | 205810 | Locate Plate | | 1 | S / D |
| | 205811 | Locate Plate | | 1 | S / E |
| 29 | WF083030 | Washer | M8X30 | 2 | |
| 30 | WS080000 | Lock Washer | M8 | 2 | |
| 31 | 205760 | Block | | 1 | S / D |
| | 201855 | T-Nut | | 1 | S / E |
| 32 | 203720 | Knob | M8×16 | 2 | S / D |
| 33 | 100203 | Lock Knob | M10 | 1 | |
| 34 | PP052000 | Pin | 5×20 | 1 | |
| 35 | 205757 | Shaft | | 1 | |
| 36 | SR089400 | Cap Screw | M8×20 | 2 | |
| 37 | 203286 | Set Screw | M8×16 | 2 | S / D |
| 38 | WF123025 | Washer | M12X30X2.5t | 1 | S / D |
| 39 | 201039 | Pad | | 2 | S / E |
| 201 | 198170A | Miter Gauge Body | | 1 | |
| 202 | NH050800 | Hex Nut | M5 | 3 | |
| 203 | SR050500 | Cap Screw | M5×25 | 3 | |
| 204 | SP049300 | Pan Head Bolt | M4×12 | 1 | |
| 205 | 201366 | Pointer | | 1 | |
| 206 | 201365 | Fixed Block | | 1 | |
| 207 | 201367 | Stop Bar | | 1 | |
| 208 | SP049400 | Pan Head Bolt | M4×16 | 2 | |

| Item | Part N° | Parts Name | Size | Qty | Note |
|------|----------|---------------|------|-----|-----------|
| 209 | 198174 | Shaft | | 1 | |
| 210 | 201364B1 | Fixed Base | | 1 | B1,F type |
| | 205721 | Fixed Base | | 1 | C type |
| | 205254 | Fixed Base | | 1 | D type |
| 211 | 017003 | Adjust Handle | | 2 | |
| 212 | 207667 | T-Bolt | | 2 | |

| Item | Part N° | Parts Name | Size | Qty | Note |
|----------|------------|--------------------|-----------------------|-------------|---------------|
| 1 | IC207010 | POWER CORD | CE | 1 | CE.3PH |
| | | VDE | 2.5x4Cx250CMx3Y1R4 | | |
| | IC207019 | POWER CORD | CSA(5HP) | 1 | CSA.3PH_5HP |
| | | CSA | 14AWGx4Cx2.5Mx6Y2R.E | | |
| | IC207022 | POWER CORD | CSA(7.5HP) | 1 | CSA.3PH_7.5HP |
| | | CSA | 12AWGx4Cx2.5Mx6Y2R.E | | |
| | IC207027 | POWER CORD | CE | 1 | CE.1PH |
| | | VDE | 2.5x3Cx250CMx2Y1R3 | | |
| | IC206302 | POWER CORD | CSA(3HP) | 1 | CSA_1PH_3HP |
| | | CSA | 14AWGx3Cx250CMx4Y2R.E | | |
| | IC206304 | POWER CORD | CSA(5HP) | 1 | CSA_1PH_5HP |
| | | CSA | 12AWGx3Cx250CMx4Y2R.E | | |
| | IC207060 | POWER CORD | CSA(5HP) | 1 | CSA.1PH_5HP |
| | | CSA 1 5HP | 8AWGx1Cx2.9Mx2Y. | | |
| | IC207061 | POWER CORD | CSA(5HP) | 1 | CSA.1PH_5HP |
| | | CSA 1 5HP | 8AWGx1Cx2.9Mx2Y. | | |
| IC207062 | POWER CORD | CSA(5HP) | 1 | CSA.1PH_5HP | |
| | CSA 1 5HP | 8AWGx1Cx2.9Mx1Y1R. | | | |
| 2 | IM207001 | MOTOR CORD | CE | 1 | CE.3PH |
| | | VDE | 2.5mm*4C*2.7M*3Y5R | | |
| | IM207004 | MOTOR CORD | CSA(5HP) | 1 | CSA.3PH_5HP |
| | | CSA | 14AWGx4Cx2.7Mx3Y5R.E | | |
| | IM207005 | MOTOR CORD | CSA(7.5HP) | 1 | CSA.3PH_7.5HP |
| | | CSA | 12AWGx4Cx2.7Mx3Y5R.E | | |
| | IM207003 | MOTOR CORD | Y | 1 | CE.CSA+Y |
| | | VDE | 2.0x7Cx270CMx6Y8R.E | | |
| IM207010 | MOTOR CORD | CE | 1 | CE.1PH | |
| | VDE | 2.5mm*3C*2.7M*2Y4R | | | |

| Item | Part N° | Parts Name | Size | Qty | Note |
|----------|-------------------|----------------------|-----------------------|-------------|---------------|
| 2 | IM207009 | MOTOR CORD | CSA | 1 | CSA.1PH_3HP |
| | | CSA | 14AWGx3Cx2.7Mx2Y4R.E | | |
| | IM207005 | MOTOR CORD | CSA(7.5HP) | 1 | CSA.1PH_5HP |
| | | CSA | 12AWGx4Cx2.7Mx3Y5R.E | | CSA.3PH_7.5HP |
| | IM207014 | MOTOR CORD | CSA(5HP) | 1 | CSA.1PH_5HP |
| | | CSA | 8AWGx1Cx2.7Mx1Y1R. | | |
| | IM207015 | MOTOR CORD | CSA(5HP) | 1 | CSA.1PH_5HP |
| | | CSA | 8AWGx1Cx2.7Mx1Y1R | | |
| | IM207016 | MOTOR CORD | CSA(5HP) | 1 | CSA.1PH_5HP |
| | CSA | 8AWGx1Cx2.7Mx2R. | | | |
| *3 | IC207028 | CONTROL PANEL CORD | | 1 | CE.CSA |
| | | | 0.75x7Cx40CMx12Y.E | | |
| *5 | IC207013 | STOP CORD | CE | 1 | S,CE, |
| | | VDE | 0.75x2Cx2.5Mx3Y1 | | |
| | IC207068 | STOP CORD | CSA | 1 | S,CSA |
| | | CSA | 18AWGx2Cx2.5Mx3Y.E | | |
| 7 | IM207002 | SCORING MOTOR CORD | CE | 1 | CE.3PH. |
| | | VDE-scoring motor | 1.0x4Cx1.8Mx6Y2R.E | | |
| | IM207006 | SCORING MOTOR CORD | CSA | 1 | CSA.3PH. |
| | | CSA-scoring motor | 16AWGx4Cx1.8Mx6Y2R.E | | |
| | IM207011 | SCORING MOTOR CORD | CE | 1 | CE.1PH. |
| | | VD-scoring motor | 1.0x3Cx1.8Mx4Y2R.E | | |
| | IM207013 | SCORING MOTOR CORD | CSA | 1 | CSA.1PH. |
| | CSA-scoring motor | 16AWGx3Cx1.8Mx4Y2R.E | | | |
| 8 | IC200802 | POWER CORD | CE | 1 | CE.3PH. |
| | | VDE | 2.5x4Cx55CMx6Y2R.E | | |
| | IC207020 | POWER CORD | CSA(5HP) | 1 | CSA.3PH_5HP |
| | | CSA | 14AWGx4Cx0.55Mx6Y2R.E | | |
| | IC207023 | POWER CORD | CSA(7.5HP) | 1 | CSA.3PH_7.5HP |
| | | CSA | 12AWGx4Cx0.55Mx6Y2R.E | | |
| | IC200802-1 | POWER CORD | CE | 1 | CE.1PH. |
| | | VDE | 2.5x3Cx55CMx4Y2R.E | | |
| | IC207030 | POWER CORD | | 1 | CSA.1PH_3HP |
| | | CSA | 14AWGx3Cx55CMx4Y2R.E | | |
| | IC207036 | POWER CORD | CSA(5HP) | 1 | CSA.1PH_5HP |
| | | CSA 1Ø 5HP | 8AWGx1Cx0.55Mx2Y. | | |
| IC207037 | POWER CORD | CSA(5HP) | 1 | CSA.1PH_5HP | |

| Item | Part N° | Parts Name | Size | Qty | Note |
|------|----------|---------------------|-------------------|-----|-------|
| 8 | | CSA7 1 5HP | 8AWGx1Cx0.55Mx2Y | | |
| *9 | IC200804 | CONTROL SWITCH CORD | | 2 | |
| | | | 18x10CMx2Y.E | | |
| *10 | IC200805 | CONTROL SWITCH CORD | | 2 | |
| | | | 18x22CMx2Y.E | | |
| 11 | IC207015 | BRAKE CORD | 2P | 1 | S,CE |
| | | VDE | 0.75x2Cx2.5Mx2I2 | | |
| | IC207055 | BRAKE CORD | 2P | 1 | S,CSA |
| | | IC207055 | 18AWGx2Cx2.5Mx2I2 | | |

8 Terms of Warranty

MAKSIWA assures the owner that their equipment, identified by the Serial number issued on the Warranty Terms.

The equipment under warranty, for two (2) years, is as followed:

1. The warranty period begins on the date of the Warranty Terms below.
2. Within the warranty period, the manual labor and the components replaced by manufacturing defect will be provided for free if duly proved by Maksiwa Service.
3. Third-party manufacturing equipment that makes up the MAKSIWA equipment (such as motors, electrical equipment, belts etc.) are subject to the terms and conditions of warranty of their respective manufacturers.
4. In case an exchange of machine is needed, please return the defective part or machine to MAKSIWA.
5. All workplace adaptations for the equipment are under the responsibility of the machine owner.
6. If you notice any defect or malfunction when receiving the equipment, get in touch immediately with the manufacturer or Dealer. Do not turn it on.
7. Not included in this warranty is any technical visits aimed at cleaning or adjustments caused by wear, resulting from normal use of the equipment.
8. The warranty does not cover problems caused by mistreatment, carelessness, misuse or inappropriate use of the functions designed for this equipment in this manual, as well as poorly executed operations by untrained operators to operate it.
9. MAKSIWA is not responsible for lost productivity, direct or indirect damages caused to the owner of the equipment or to third parties, or any other expense, including lost profits.
10. This equipment requires the use of a dust collection system with a minimum of 2 hp.
11. Even under warranty, you may lose its validity as follows:
 - a) Application of non-original components;
 - b) Alteration of its original features;
 - c) Lack of proper maintenance;
 - d) Improper use of the equipment;
 - e) Change in equipment or electronic connections;
 - f) Damage caused by mechanical shock or exposure to unsuitable conditions (humidity, salt spray, corrosive agents, etc.);
 - g) Damage caused by bad weather (floods, flooding, lightning, power outages etc.);
 - h) Maksiwa is not responsible for damages to electrical components cause by power variation in your area.

h) Removable of safety equipment will void your warranty. (Riving Blade, Blade Cover, etc.).

For your safety, trust the repairs, maintenance and adjustments (including inspection and replacement) for technical assistance recommended by MAKSIWA, always use genuine spare parts and accessories, reassembling to its original machine the same way.

MODEL:

SERIAL NUMBER:

DATE:

LOT NUMBER:

Imported by:

Maksiwa International Inc.

4100 N Powerline Rd, Suite D3

Pompano Beach, Florida

ZIP Code: 33073

Telephone: +1 (754) 205-6717 | Call us free: +1 (844) 319-6594

E-mail: customer.service@maksiwa.com

www.maksiwa.com